



**U.S. Department of Housing and Urban Development
Office of Policy Development and Research**

Design, Fabrication, and Installation of Engineered Panelized Walls: Two Case Studies



PATH (Partnership for Advancing Technology in Housing) is a new private/public effort to develop, demonstrate, and gain widespread market acceptance for the “Next Generation” of American housing. Through the use of new or innovative technologies, the goal of PATH is to improve the quality, durability, environmental efficiency, and affordability of tomorrow’s homes.

PATH is managed and supported by the U.S. Department of Housing and Urban Development (HUD). In addition, all federal agencies that engage in housing research and technology development are PATH Partners, including the Departments of Energy, Commerce, and Agriculture, as well as the Environmental Protection Agency (EPA) and the Federal Emergency Management Agency (FEMA). State and local governments and other participants from the public sector are also partners in PATH. Product manufacturers, home builders, insurance companies, and lenders represent private industry in the PATH Partnership.

To learn more about PATH, please contact



451 7th Street, SW
Washington, DC 20410
202-708-4277 (phone)
202-708-5873 (fax)
e-mail: pathnet@pathnet.org
website: www.pathnet.org

Visit PD&R's website

www.huduser.org

to find this report and others sponsored by
HUD's Office of Policy Development and Research (PD&R).

Other services of HUD USER, PD&R's Research Information Service, include listservs; special interest, bimonthly publications (best practices, significant studies from other sources); access to public use databases; and a hotline 1-800-245-2691 for help accessing the information you need.

Design, Fabrication, and Installation of Engineered Panelized Walls: Two Case Studies

Prepared for

U.S. Department of Housing and Urban Development
Office of Policy Development and Research
Washington, DC

Contract No. C-OPC-21289

by

NAHB Research Center, Inc.
Upper Marlboro, Maryland

January 2002

Acknowledgments

This report was prepared by the NAHB Research Center under contract to the U.S. Department of Housing and Urban Development (HUD). Special recognition is given to William Freeborne and Dana Bres for their input and review. The following individuals are acknowledged for their contribution to this project:

Vladimir Kochkin, Principal Investigator
Jay Crandell, PE, Technical Reviewer
Danny Feazell, Premium Steel Building Systems
Tien Peng, Quadrant Homes
Ed Hawkinson, Woodinville Lumber
David Motter, PE, Woodinville Lumber
Jim Schumacher, Woodinville Lumber
Lynda Marchman, Administrative Support
Kimberlee Jackson, Administrative Support
Brian Adgate, Laboratory Support
Anthony Osborne, Laboratory Support

NOTICE

The work that provided the basis for this publication was supported by funding under a grant with the U.S. Department of Housing and Urban Development. The substance and findings of the work are dedicated to the public. The authors are solely responsible for the accuracy of the statements and interpretations contained in this publication. Such interpretations do not necessarily reflect the views of the Government.

While the information in this document is believed to be accurate, neither the authors, nor reviewers, nor the U.S. Department of Housing and Urban Development, nor the NAHB Research Center, Inc., nor any of their employees or representatives makes any warranty, guarantee, or representation, expressed or implied, with respect to the accuracy, effectiveness, or usefulness of any information, method, or material in this document, nor assumes any liability for the use of any information, methods, or materials disclosed herein, or for damages arising from such use.

ABOUT THE NAHB RESEARCH CENTER, INC.

The NAHB Research Center, Inc. is a not-for-profit subsidiary of the National Association of Home Builders (NAHB). The NAHB has 203,000 members, including 60,000 builders who build more than 80 percent of new American homes. The NAHB Research Center conducts research, analysis, and demonstration programs in all areas relating to home building and carries out extensive programs of information dissemination and interchange among members of the industry and between the industry and the public.

FOREWORD

Panelized wall construction presents significant opportunities to improve housing quality, safety, and affordability. While panelized wall construction is a well-known building technology, it has seen only limited use and its benefits are largely untapped. In part, this situation may be a result of technical and procedural barriers to optimum use of panelized wall systems.

This publication provides an evaluation of current technology used in the design, fabrication, and installation of panelized walls systems, including engineered wood frame walls and an innovative steel frame wall system. In addition, procedures used for regulatory approval and, ultimately, the delivery of products and services associated with panelized wall construction are documented. Where appropriate, recommendations for improved technology and procedures are provided.

Two case study projects provided for a “real world” evaluation of existing panelized wall systems used in the home construction industry. One case study, a custom home, was located in an area subject to hurricane-force winds. The other case study, a production-built home, was located in an area subject to severe earthquakes. At one of the sites, innovative engineering technology from previous HUD-sponsored research was used to demonstrate advanced methods for design, fabrication, and installation of panelized wall systems. This innovative approach to building design and construction holds promise of greater affordability and safety, particularly for homes built in the most hazardous areas of the United States.

A companion document titled *Model Guidelines for Design, Fabrication, and Installation of Engineered Panelized Walls*, implements many of the findings and recommendations made in this document. In particular, it addresses key technology and procedural barriers to the effective use of conventional and innovative panelized wall systems.

Harold L. Bunce
Deputy Assistant Secretary for
Economic Affairs

TABLE OF CONTENTS

	PAGE
Introduction.....	1
Background Information.....	1
Path Panelized Technology Roadmapping	1
Historical Overview Of Residential Panelized Wall Construction	2
Document Organization	2
Case Studies.....	3
General.....	3
Case Study I - Cold-Formed Steel Panelized Construction.....	3
Case Study II - Light-Frame Wood Panelized Construction.....	21
Project Summary and Conclusions	37
Appendix A - Analysis of the Lateral Force Resisting System of the Demonstration House Located in Beaufort, SC (Case Study I)	
Appendix B - Analysis of the Lateral Force Resisting System of the Demonstration House in Renton, WA (Case Study II)	
Appendix C - Rigid Diaphragm Method	
Appendix D - Metric Conversion Factors	

LIST OF TABLES

	PAGE
Table 1 - Responsibilities of Parties	4
Table 2 - Fastening Schedule	17
Table 3 - Shear Wall Performance Parameters	18
Table 4 - Length Effects Comparison for Traditional and ThermaSteel® Shear Walls.....	19
Table 5 - Responsibilities of Parties	22
Table 6 - Fastening Schedule	34

LIST OF FIGURES

	PAGE
Figure 1 - Case Study I – Project Team	4
Figure 2 - ThermaSteel™ Panel.....	6
Figure 3 - Case Study I: Isometric Drawing of the Demonstration Building	7
Figure 4 - Panel Configurations.....	11
Figure 5 - Transportation of the Wall Panels by Trailer.....	12
Figure 6 - Panel Installation.....	12
Figure 7 - Wall Bracing	13
Figure 8 - Wall Construction	14
Figure 9 - Test Platform.....	15
Figure 10 - Shear Wall Test Setup.....	17
Figure 11 - Sheathing Fastening Schedules for Traditional and ThermaSteel™ Construction.....	19
Figure 12 - Failure Mode of Wall 2.....	20
Figure 13 - Case Study II – Project Team.....	22
Figure 14 - Fabrication of Light-Frame Wall Panels.....	23
Figure 15 - Case Study II: Replica of Demonstration House	25
Figure 16 - Wall Panel Production Line	27
Figure 17 - Wall Panel Being Framed	27
Figure 18 - Application of Sheathing Panels	28
Figure 19 - Machining of Panel Openings.....	28
Figure 20 - Multiple Nail Gun Rack for Attaching Sheathing Panels	29
Figure 21 - Panel Handling and Packaging.....	29
Figure 22 - Typical Site-Built Strap Installation.....	30
Figure 23 - Strap Installation on Panelized Walls with Precut Sheathing Panels.....	31
Figure 24 - Buckled Holddown Strap.....	32
Figure 25 - Truss Plate Holddown.....	33
Figure 26 - Test Wall Configuration and Test Setup.....	34
Figure 27 - Wall Framing with Truss Plates.....	35
Figure 28 - Arrangement of Framing Members at the Wall Corner	35
Figure 29 - Holddown Instrumentation.....	36

INTRODUCTION

The technology of manufacturing wall panels in a factory and delivering them to the construction site for assembly is known as panelized wall construction. Although the panelized wall construction technology offers great potential, such as reduced construction cycle time and improved framing quality, the majority of new houses in the United States are still framed on-site using “stick-built” practices. Due to extensive practical experience, the “stick-build” approach is often viewed as the preferred, traditional, and historically “proven” method of construction, yet it can become the limiting factor for introducing advanced management, construction, and engineering practices in the framing process.

If successfully implemented, panelized wall construction can provide a spectrum of benefits by relocating the wall framing operations from the construction site to the controlled factory environment. Factory operations can be optimized and automated for mass production of the wall panels that are engineered to meet the structural and functional specifications. Furthermore, the factory environment provides methods for more efficient utilization of materials and human resources. Moreover, the panelized construction technology can successfully incorporate innovative and improved wall systems developed through research and engineering to economically meet the performance-based building code provisions.

Realizing the conflict between the potential of panelized wall construction and the relatively weak position of the panelized wall industry in the current residential market, the NAHB Research Center designed and conducted two case studies with the objective to:

1. demonstrate and communicate panelized wall construction methods to the residential building industry;
2. identify the barriers to a wider acceptance of panelized wall construction;
3. examine current engineering practices used by the panelized wall industry; and,
4. based on results of the first three objectives, provide feedback relevant to development of a standardized guideline for panelized wall construction.

BACKGROUND INFORMATION

PATH PANELIZED TECHNOLOGY ROADMAPPING

This project is one task under a much larger program known as the Partnership for Advanced Technology in Housing (PATH) sponsored by the U.S. Department of Housing and Urban Development (HUD). The goals of this industry and government collaborative effort are to evaluate, demonstrate, and advance the current state of the art of housing in the areas of Durability, Energy Efficiency, Environmental Impacts, Safety, and Affordability. The primary areas of interest in this project on engineered panelized walls include affordability and structural safety.

In 2000, the NAHB Research Center with involvement of the industry experts conducted technology roadmapping that identified and evaluated available panelized walls systems. The roadmapping further identified areas where advances were needed to promote the panelized wall technology in residential construction. The results of the roadmapping provided invaluable insights into the industry needs and helped start defining future tasks needed to promote

panelized wall construction. As one of these tasks, two case studies on light-frame panelized wall construction were conducted. Results of this project were summarized in this report. A companion project to develop model guidelines for design, fabrication, and installation of panelized walls is separately published by HUD.

HISTORICAL OVERVIEW OF RESIDENTIAL PANELIZED WALL CONSTRUCTION

Historically, residential buildings in the United States are built on-site using “stick-built” methods. Framing materials such as lumber, sheathing, and connectors are shipped to the construction site where they are assembled into walls, platforms, and roofs. All operations including storage, precutting of lumber and sheathing panels, and framing are performed on site manually or using portable light-duty tools. After introduction of metal truss plates in the residential market in the 1950s, many homebuilders began using prefabricated trusses to construct floors or roofs or both. The truss manufacturers were established as independent businesses that were not involved in the construction process or they were directly or indirectly affiliated with either the framer or general constructor. In either case, the truss manufacturers realized an opportunity in manufacturing wall panels along with the trusses that are delivered to the site for assembly as one structural package. The method of fabricating the wall panels in a factory was referred to as a panelized wall construction technology. Since its introduction to the marketplace, the panelized wall industry diversified and developed into a wall component industry producing stand-alone wall panel products and complete structural wall systems made of various materials and with employment of different fabrication and construction methods. Despite the advantages of the panelized wall technology identified throughout this document, this type of construction accounted for only 5.2 percent of the linear feet of light-frame frame walls in residential construction in 1999¹.

DOCUMENT ORGANIZATION

This report is organized into four sections: Introduction, Case Studies, Conclusions and Recommendations, and Appendices.

The *Introduction* emphasizes significance and highlights benefits of panelized wall construction in the residential housing industry. It further formulates the problem statement and objectives of the case studies. The concept and results of the PATH panelized technology roadmapping are presented. A short summary of history of panelized light-frame construction is also presented.

The second section presents two *Case Studies* that demonstrate panelized wall technology and examine fabrication, installation, management, and engineering practices relevant to development of a guideline for panelized wall construction. Both case studies are organized according to the same format. Each case study has a *Summary and Conclusions* section that addresses the issues relevant to the respective study.

The third section summarizes the document and draws comprehensive conclusions based on the results of the investigation and outcome of both case studies. Recommendations are given with respect to the problem statement and project objectives formulated in the *Introduction* section.

¹Annual Builder Practices Survey, NAHB Research Center, 2000.

Appendices A and B include engineering calculations that substantiate design concepts presented and discussed in Case Studies I and II, respectively. *Appendix C* provides supplemental information on the rigid diaphragm method for lateral force distribution in light-frame construction.

CASE STUDIES

GENERAL

This section presents two cases studies of panelized wall design, code approval, fabrication, and construction. Each case study uses a demonstration house selected for observation and analysis of the panelized wall technology. Although the scope of this document covers all types of panelized walls including load bearing and nonbearing walls, shear walls are the focus of the engineering evaluation of panelized wall construction. An effort is made to scrutinize the engineering methods and substantiation procedures used by the demonstration participants for structural design of lateral force resisting systems. Shear walls of both buildings are analyzed using innovative engineering methods and recommendations for improvements or novel design solutions are provided. Case Study I investigates implementation of cold-formed (i.e., light-gage) steel panelized wall construction in a high wind area, and Case Study II investigates implementation of light-frame wood panelized wall construction in a high seismic area. The construction sites are located in high hazard regions that require advanced engineering and allow for demonstrating both the design challenges and effective structural solutions. Moreover, the functions and responsibilities of each party involved in the building process are documented and examined.

CASE STUDY I – COLD-FORMED STEEL PANELIZED CONSTRUCTION

Introduction and Objectives

This study investigated light-gage steel panelized wall construction in a high wind region (Beaufort, SC). The specific objective was to examine the process of implementing a proprietary panelized wall system within the existing building code regulation. In particular, the substantiation procedures used to develop engineering design data for obtaining building code approval (i.e., local building permit) were evaluated.

Roles and Responsibilities

A flow-chart (Figure 1) shows the parties involved in the project and relationships between the parties. Table 1 summarizes responsibilities of each party as observed during the building construction process.

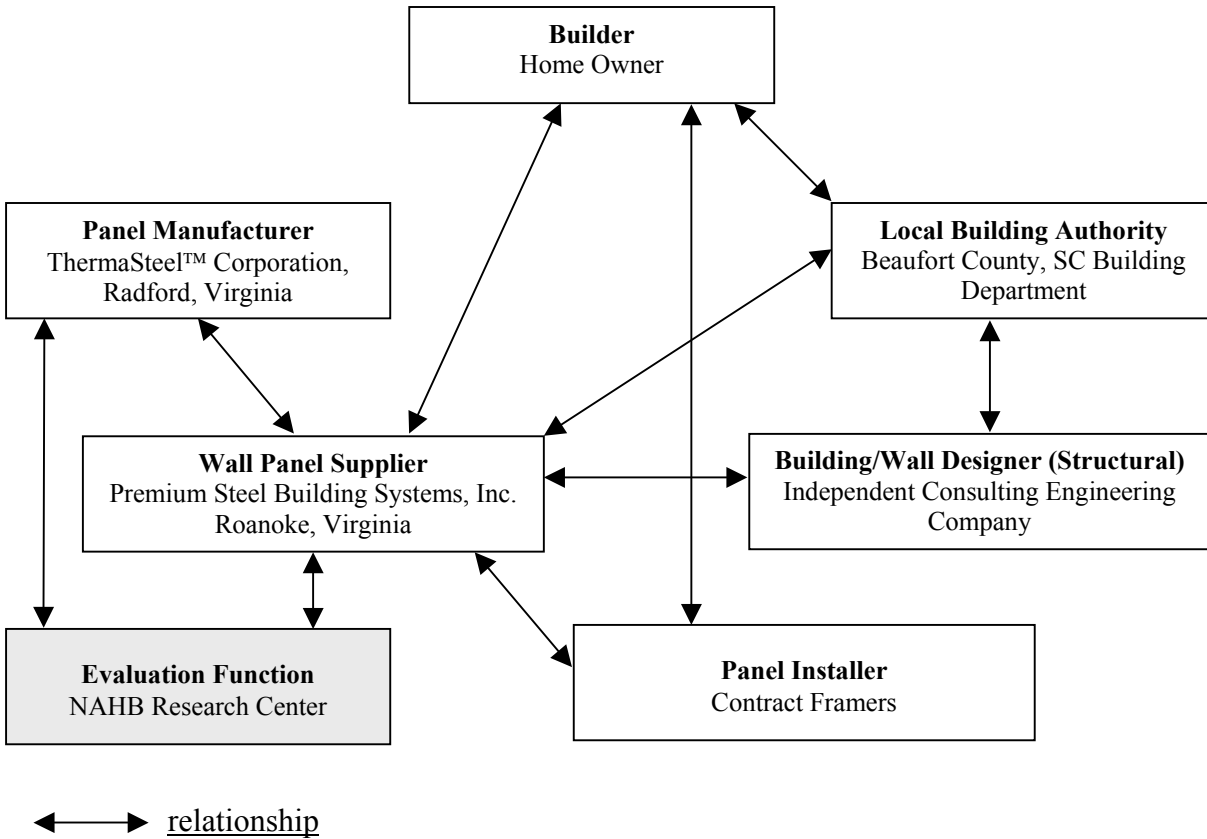

Figure 1
Case Study I – Project Team

TABLE 1
RESPONSIBILITIES OF PARTIES

Party	Description of Functions
Builder – Home Owner	- Management of the construction process including hiring of subcontractors and obtaining building code approval
Wall Panel Supplier	- Provided complete light-gage steel structural package including wall panels, floor joists, and roof rafters - Assisted in the framing process, trained framers in light-gage steel construction and ThermaSteel™ system - Provided panel shop drawings and customized the panel configurations to meet the building plan provided by the Builder - Communicated design and construction information between the involved parties
Panel Manufacturer	- Provided ThermaSteel™ wall panel system - Provided Building Code Evaluation Report with engineering data and construction specifications
Building/Wall Designer – Structural	- Structural design of the building components and systems
Local Building Authority	- Reviewed engineering calculations, performed quality inspections, and enforced building code compliance
Panel Installer – Contract Framers	- On-site wall construction
NAHB Research Center	- Evaluation function

The project was managed by the home owner who hired subcontractors and obtained the building permit. Wall panels were supplied as a part of a complete structural package, including TradeReady® floor system and light-gage steel rafters, by Premium Steel Building Systems, Inc. located in Roanoke, Virginia. The wall panels were manufactured by ThermaSteel™ Corporation located in Radford, Virginia. The panel manufacturer was not involved in the building design or construction. The structural building design was performed by an independent engineering company to the extent requested by the local building code authority. The design of walls was performed on the basis of the engineering data provided by the panel manufacturer. The local building authority communicated with the builder, panel supplier, and the engineering company, and conducted on-site quality control and building code compliance inspections during the building construction. The NAHB Research Center conducted evaluation of the panelized wall construction process.

Excluding the NAHB Research Center, a total of six parties participated in the wall construction process. The flow-chart (Figure 1) reveals that the wall panel supplier played an integral role in the construction of the house structure through supplying materials, communicating technical and design information, and providing training for the builder employees to assure proper on-site construction practices. Therefore, the panel supplier performed functions of a facilitator and a mediator which resulted in an efficient project management strategy. Each party communicated with the panel supplier and only one or two other project participants instead of all five other parties.

In contrast, if the walls were constructed using traditional “stick-built” methods, only three parties would participate in the process: home owner (or general contractor), framer, and local building authority. The traditional construction methods are often based on local practices that are well known and understood by all involved parties. Therefore, a similar role of a “middleman” is redundant or unnecessary.

ThermaSteel™ Panelized Wall System

The walls of the demonstration building were constructed using ThermaSteel™ panels. The ThermaSteel™ panelized system is a proprietary technology that incorporates a unique process of panel fabrication. The panels are fabricated in factories located in several countries around the world. In the United States, the panels are produced by the ThermaSteel™ Corporation based in Radford, Virginia.

A ThermaSteel™ panel consists of galvanized cold-formed steel framing and polystyrene foam (Figure 2). The panels are manufactured using proprietary equipment in a low pressure molding process. Although a variety of steel sections can be used, a typical ThermaSteel™ panel is made with 24 gage steel galvanized with G-90 Grade B coating². Within a wall panel, steel framing members are attached to each other and to the foam with adhesives applied to the interior surfaces of the framing members. Polystyrene foam, with density ranging between 1.0 and 1.5 lbs/ft³, provides insulation and some structural function. The structural function is to provide lateral support for steel members in addition to support provided by components attached to the

²ASTM Standard A 653, Standard Specification for Steel Sheet, Zinc-Coated (Galvanized) or Zinc-Iron Alloy-Coated (Galvannealed) by the Hot-Dip Process, American Society of Testing and Materials (ASTM), West Conshohocken, PA, 2001.

wall. The steel frame members are arranged within the panel such that there are no continuous steel elements from the exterior to the interior surfaces of the panel. This panel configuration eliminates the thermal bridging effect and improves the panel thermal resistance characteristics. The panels can be produced in a variety of sizes. The most common dimensions are 3.5 and 5.5 inches thick, 4 feet wide, and 8 and 9 feet tall.

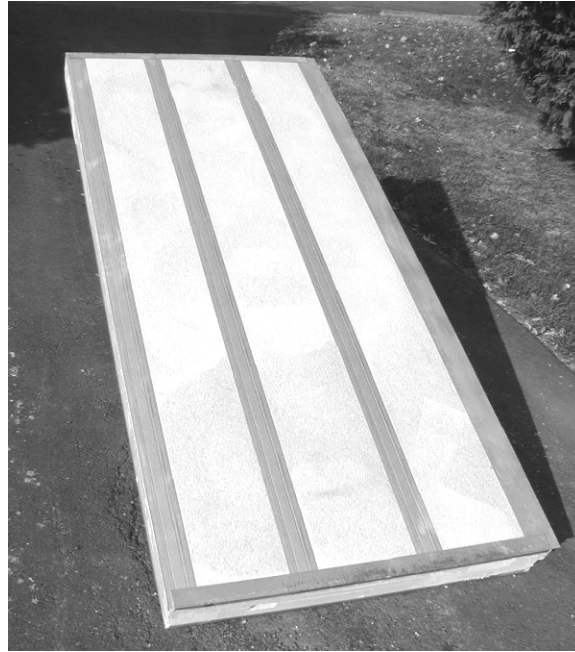

Figure 2
ThermaSteel™ Panel

The panels are attached to each other and to adjacent elements using self-drilling, self-tapping screws. The panels can be equipped with fastening tabs that facilitate on-site fabrication of joints. Supplemental steel components (e.g., track section, L-shaped section, plates, etc.) are shipped with the panels to provide methods for interconnecting the panels and connecting the panels to other members. In addition, the panels can be molded with a shiplap joint for precision fit.

ThermaSteel™ panels serve a dual function of providing thermal insulation and structural resistance. All exterior walls are constructed with ThermaSteel™ panels for insulation purposes, and at the same time perform as structural walls. The interior walls are typically framed on site according to conventional practices. Although the interior walls provide additional shear resistance, the common engineering practice is to ignore their contribution. This conservative assumption results in building designs with increased reserve capacities. As an exception, interior partitions between the garage and the rest of the house are also constructed with ThermaSteel™ panels, because the garage is not heated in the same manner as the living space. Therefore, an additional layer of insulation is required between the garage and the adjacent living space. These partitions are attached directly to the concrete foundation and can be explicitly included in the design of lateral force resisting system.

Demonstration House

The demonstration house was built in Beaufort, South Carolina, in a new development as a future primary residence of the owner. The house is located on St. Helena Island approximately

seven miles from the Atlantic Ocean coastline. Trees protect the house from the north, south, and east, whereas the west side is an open wetland (approximately 1.0 miles). The house location corresponds to wind speed of 130 mph³ based on 3-second gust and exposure category C based on the west direction. Figure 3 shows an isometric drawing of the building. The plan is 92 feet by 55 feet and maximum roof height is 30 feet from the ground level. This house is a 1-1/2-story building constructed on a stem wall foundation with a 4-foot crawl space. The roof system is a combination of hip and gable forms with 12:12 pitch.

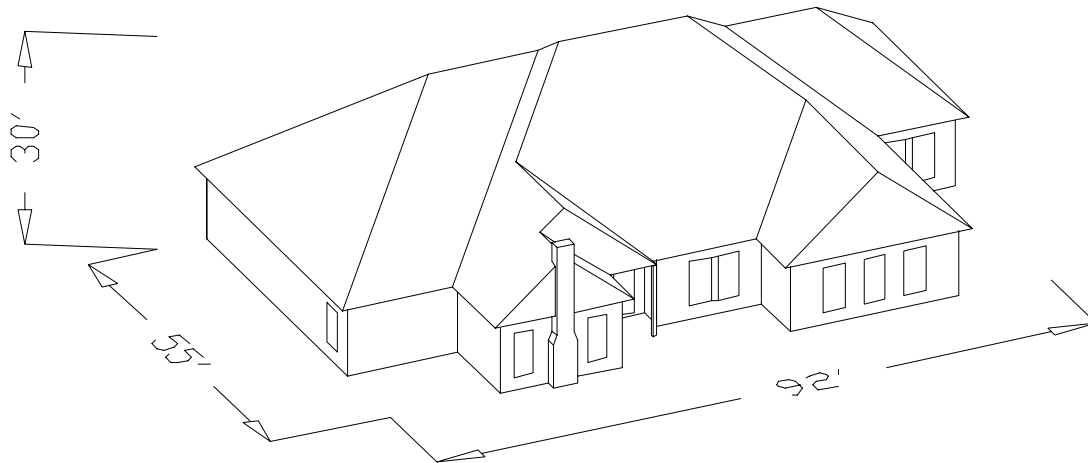

Figure 3
Case Study I: Isometric Drawing of the Demonstration Building

The footing was constructed with reinforced concrete. The stem walls were made of 4-foot-tall and 12-foot-long ThermaSteel™ panels. A TradeReady® floor system, manufactured by Dietrich Metal Framing, Inc., was installed on top of the stem walls and sheathed with 23/32-inch-thick Oriented Strand Board (OSB) panels. ThermaSteel™ wall panels were installed on the floor platform per specifications provided by ThermaSteel™ Corporation, Radford, Virginia. Another TradeReady® floor platform was installed on top of the wall panels and sheathed with 23/32-inch-thick OSB panels. The roof was constructed with light-gage steel rafters and sheathed with 7/16 OSB panels. The interior partitions were constructed on-site using light-gage steel studs.

³Minimum Design Loads for Buildings and Other Structures, ASCE 7-98, American Society of Civil Engineers (ASCE), Reston, VA, 2000.

Regulatory Approval Process

Because the ThermaSteel™ panel technology is beyond the scope of the model building codes, the panel manufacturer holds building code evaluation reports from three major code evaluation agencies operated by Building Officials and Code Administrators International Inc. (BOCA), International Conference of Building Officials (ICBO), and Southern Building Code Congress International, Inc. (SBCCI). An additional evaluation report was obtained from HUD. The evaluation reports provide detailed technical specifications on the panel assembly methods, the scope of the product implementation, and engineering data for use with structural analysis procedures. However, the final decision on whether information from one of the evaluation reports can be used to design and build a house in a particular region of the country is under the jurisdiction of the local building authority.

To assure that technical characteristics and quality of ThermaSteel™ panels are consistent with the specifications provided in the evaluation reports, a third-party agency performs periodic testing of panels randomly selected from the production line. This testing program allows for independent verification of the performance parameters of the panel products. These independent audits are particularly critical for this proprietary system, because the product user often has limited knowledge of the product due to both the proprietary nature of the product and limited experience with the product as compared to traditional widely-used construction systems. Thus, the user can potentially fail to identify defects and to recognize inconsistencies with the product standards and quality guidelines.

The evaluation procedures for wall panels established by the code approval agencies are often inconsistent with each other and can be further amended by the local building authority. This practice can create a barrier to development of novel panelized wall products and can impede the use of such products across the country. A consistent basis for structural evaluation of wall performance and for methods of quality assurance for innovative panelized wall products can contribute to advancement of engineered panelized wall systems in residential construction.

The specific requirements for structural design are established by the local building authority based on the provisions of the local governing building code. The majority of localities in the United States permit the use of prescriptive code provisions for residential construction without employing services of a licensed design professional. However, building code provisions in the hurricane-prone regions located along the coastline of the Atlantic ocean of the eastern United States are generally more stringent requiring each building plan to be reviewed by a licensed architect or engineer to ensure structural integrity of the building under high-wind loads. These practices vary considerably between the states and counties in regard to the degree of the involvement of the licensed professional. Because Beaufort, SC, is a hurricane-prone area, the panel supplier employed services of engineering company which provided a structural analysis to the extent requested by the local building authority.

Lateral Force Design Methods

The lateral forces resulted from wind pressure are resisted by a system of diaphragms and shear walls which further transfer the forces into the foundation. The design resistance of traditional wood shear wall systems can be determined from the model building codes such as Standard Building Code (SBC) (SBCCI), National Building Code (NBC) (BOCA), Uniform Building

Code (UBC) (ICBO), and International Building Code (IBC) (ICC). The resistance of cold-formed steel shear walls are reported in more recent building codes (IBC). If a shear wall configuration is not covered by the code provisions, an evaluation report is usually obtained from a recognized code evaluation agency. The evaluation reports contain design shear wall values for use with lateral structural analysis procedures.

The lateral analysis procedures for light-frame construction vary between the model building codes in respect to the design approach, safety margins, design format, design basis, reference design values, etc. Moreover, the intent behind many of the building code requirements is often not explicitly stated and is not available to the designer. As a result, a proprietary system can be more competitive in one geographical region than in another. Although differences in local building code provisions can be driven by the differences in the local loading conditions (e.g. wind vs. seismic), they can misdirect both the evaluation and design processes creating unfavorable conditions for development of innovative structural systems. For detailed description of the lateral structural analysis methods the reader is referred to the *Model Guidelines for Design, Fabrication, and Installation of Engineered Panelized Walls*⁴.

Because the weight of light-frame construction is generally insufficient to resist the uplift forces resulting from high wind pressures in hurricane-prone regions, a continuous load path should be designed to transfer all forces to the foundation. This load path incorporates a fastening system that interconnects individual elements of the structure and provides anchorage to the foundation. The load path should be detailed such that the local failure of any one component or element of the structural system does not precipitate immediate and catastrophic damage to the remaining structure. This issue is particularly important in the high hazard regions where improper load path detailing can result in greater potential damages as compared to other areas of the country. With respect to shear wall design, the continuous load is provided by proper anchorage of the walls to either floor platform or foundation. The panelized engineered wall technology can provide effective means and methods for engineering and construction of shear walls with a continuous load path. For example, overturning restraints can be designed and detailed to be integral to the wall panels fabricated in a factory for accelerated and simplified on-site panel installation.

The shear wall design and code approval issues associated with the current building code practices relevant to ThermaSteel™ system are discussed in Section *Design and Approval Process Evaluation* and recommendations are given where improvements are needed. The design methods involved in structural analysis of a single-family house in a hurricane-prone region are exemplified in Appendix A using the demonstration home configuration. Seismic analysis is beyond the scope of Case Study I. The reader is referred to Case Study II for discussion on the aspects of seismic design.

Panel Fabrication

A detailed description on fabrication of ThermaSteel™ panels is beyond the scope of this report due to the proprietary nature of this product. Both the panel product and the manufacturing technology are patented and protected under the patent law.

⁴Model Guidelines for Design, Fabrication, and Installation of Engineered Panelized Walls, U.S. Department of Housing and Urban Development, Washington, DC, 2001.

The panels were manufactured by ThermaSteel™ Corporation in accordance with the shop drawings provided by Premium Steel Building Systems, Inc. (panel supplier). The panel supplier also fabricated hardware such as bottom and top steel track, L-shaped steel section, supplemental steel plates, etc. that were used to assemble the panels into walls. The shop drawings were custom-developed to meet the architectural building specifications supplied by the builder. The wall panel configurations included: regular wall panels (Figure 4a), header panels (Figure 4b), cripple wall panels for use under window openings, stem wall panels for use as crawl space walls, panels with molded-in recessed columns for accommodation of headers (Figure 4c), irregular-shaped panels for framing gable end walls, panels with window openings (Figure 4d), and irregular width panels for use at the corners to conform with the overall wall dimensions and for use between windows to conform with the architectural requirements (Figure 4e). The panels were manufactured as a complete wall package that did not require any additional modifications before installation.

The controlled factory environment allows for optimization of the panel manufacturing process. The panels are fabricated using stationary heavy-duty equipment and tools that enable mass production of the panels. Moreover, the quality and consistency of the product are improved compared to on-site construction. Personnel resources are more efficiently utilized due to reduced manual labor and division of labor. The material waste is minimized through promoting reuse of remnants for less important or nonstructural applications.

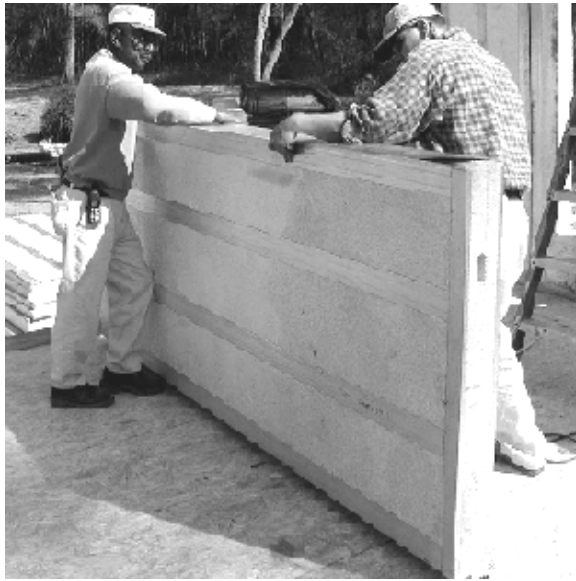

a.



b.



c.

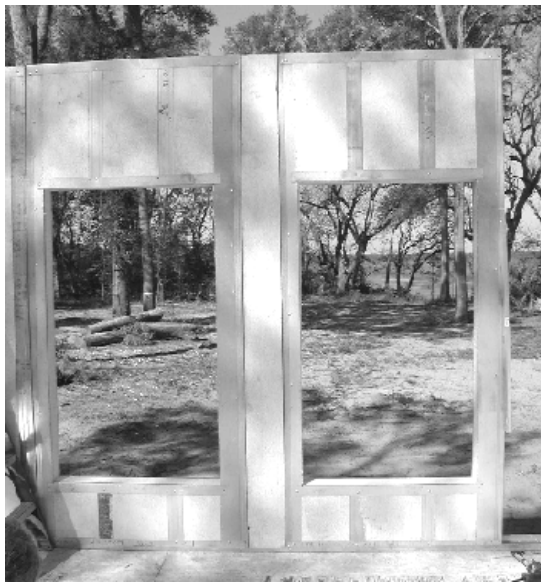

d.



e.

Figure 4
Panel Configurations

Panel Transportation and Installation

ThermaSteel™ wall panels were delivered to the construction site on a trailer (Figure 5). The panels were stacked on wooden pallets as solid packages strapped to the trailer. Because the panels were manufactured with corrosion resistant steel members and insulation inert to the environmental factors under relatively short exposure the panels did not require any special packaging considerations. Because of light weight and small size individual panels were unloaded manually.



Figure 5
Transportation of the Wall Panels by Trailer

ThermaSteel® panels can be installed by a crew of two workers equipped with a power screw driver light-gage steel shears a ladder and a level. A 4 foot by 9 foot 5.5-inch-thick panel weighs approximately 45 pounds and can be positioned in place by one person (Figure 6).



Figure 6
Panel Installation

The wall assembly process was not labor intensive and required minimal professional training. The installation of panels for exterior walls of the demonstration house was completed in two days by a crew of four. A simple wall assembly sequence was used to increase the effectiveness of the wall construction process:

1. a level and square floor platform was prepared prior to the wall construction;
2. panels were set on the platform next to the indicated position of installation;
3. a light-gage steel track was attached to the platform;
4. a panel was inserted into the bottom track and the vertical position of the panel was checked with a level;

5. while the first crew member held the panel in the vertical position, the second crew member fastened the track to the wall studs using #8 wafer head, self-drilling screws on both sides of the wall;
6. the panel was attached to the adjacent panel through a fastening tab using the same #8 wafer head self drilling screws; at the building corners the panels were fastened to each using L-shaped sections;
7. as the wall length exceeded 12 feet, a 12-foot track was installed on top of the wall and attached to the panels in the same manner as the bottom track; and,
8. temporary wall braces were installed at 8 to 10-foot intervals (Figure 7).



Figure 7
Wall Bracing

A set of photographs (Figure 8) shows the wall construction sequence. The first photograph was taken in the morning of the first day, whereas the last photograph was taken in the morning of the second day when the installation crew was finishing the garage portion of the building (hidden).



a. Unsheathed floor platform



b. Sheathed floor platform and first set of panels



c. North, East, and West walls completed

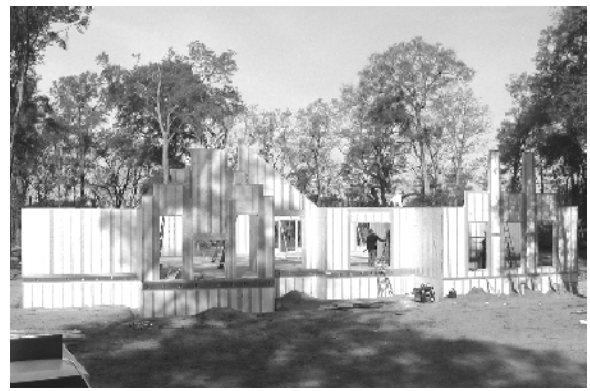

d. All exterior walls completed

Figure 8
Wall Construction

Three types of header systems were installed depending on the width of the opening: (1) openings 3.5-feet-wide or less were made during the panel molding process with built-in headers, (2) openings 3.5 to 5-feet-wide were framed with header panels that were attached to the adjacent panels with screws through fastening plates on both panel faces, and (3) openings 5-feet-wide and wider were framed with header panels that rested on recessed columns built into the adjacent panels and also fastened to the adjacent panels using fastening plates as type 2 headers. The building designer analyzed headers including sizing of steel framing and providing adequate load transfer into the receiving panels.

Design and Approval Process Evaluation

One of the objectives of this investigation was to examine the process of developing design shear wall values for proprietary wall panels and to investigate application of these values to the lateral building analysis. The design values documented in an evaluation report⁵ prepared by HUD were used in this study.

The allowable shear value for the panel configuration used in the demonstration house is 311 lb/ft provided that 1/2-inch-thick gypsum panels are attached to the interior surface of the wall

⁵Structural Engineering Bulletin NO. 1072, Department of Housing and Urban Development, Washington, DC, 1997.

with drywall screws spaced a minimum of 12 inches on perimeter and in field. The allowable design value is defined as the ultimate test resistance divided by a safety factor of 2.5.

Although the evaluation report does not specify the method that has been used to test the panels in shear, the typical practice is to follow the provisions of the ASTM Standard E 72 - 95 “Standard Test Methods of Conducting Strength Test of Panels for Building Construction” or ASTM Standard E 564 - 95 “Standard Practice for Static Load Tests for Shear Resistance of Framed Walls for Buildings”⁶. Both of these standards require that the uplift forces are resisted by a setup fixture or a holddown restraint so that the wall segment is tested in a manner that results in a racking shear failure. Unless the wall in the building is similarly restrained against overturning, it develops a resistance lower than that measured during testing due to a potential premature uplift connection failure. However, the evaluation report does not explicitly define the anchorage conditions necessary to achieve the specified resistance. This creates a situation for potential misinterpretation of the test data presented in the evaluation report leading to a house design with uncertain safety margins.

Two 9 foot by 12 foot nonperforated shear wall segments assembled with ThermaSteel™ panels were tested to evaluate lateral resistance of the walls used in the demonstration building. The test walls were constructed on a TradeReady® floor platform attached to a rigid steel foundation using anchorage methods specified by the panel supplier and consistent with the provisions of the International Residential Code for One- and Two-Family Dwellings (IRC)⁷. Figure 9 shows a corner section of the test floor platform. The rim joists were secured to the platform with four L-shaped angles spaced 4 feet on center which were attached to the foundation with 1/2-inch diameter bolts and fastened to the joist with 5 #10 screws. The first bolt was positioned 12 inches from the platform corner. The platform was sheathed with 23/32-inch-thick OSB subfloor panels.

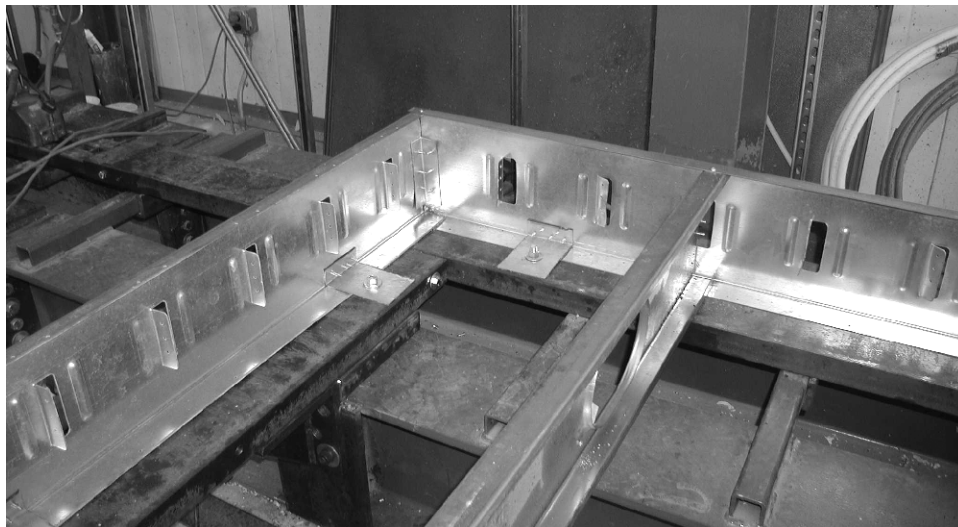

Figure 9
Test Platform

⁶Annual Book of ASTM Standards, Volume 04.11, Building Construction, American Society of Testing and Materials, West Conshohocken, PA, 1997.

⁷International Residential Code for One- and Two-Family Dwellings (IRC), International Code Council (ICC), Inc., Falls Church, VA, 2000.

The walls were constructed in accordance with the specifications provided by the panel supplier and the technical information provided in the evaluation report. The construction practice was consistent with that used in the demonstration house. Interior sheathing was not installed. Table 2 summarizes the fastening schedule used with the test specimens. Two wall configurations were tested: (1) without an additional holddown device to resist the wall uplift, and (2) with a holddown device to resist the wall uplift. One specimen of each wall configuration was tested. The first wall configuration was consistent with the practice recommended by the panel distributor for residential construction and was planned to be implemented with the demonstration house. The second configuration was tested to investigate the effect of the holddown bracket, and to determine the ultimate capacity of a fully restrained wall in accordance with the practice used by the panel manufacturer to obtain the building code evaluation report.

The specimens were loaded through a 0.25 inch by 3.5 inch metal plate fastened to the top of the wall with #1/4 Grabber® screws spaced 5 inches on center. Tension load was applied to the strap by a hydraulic cylinder acting in retraction. The application of load in tension, as opposed to compression loading recommended by the ASTM Standard E 564, prevented the introduction of additional uplift forces due the cylinder rotation. The use of a thin plate minimized the effect of an increased top plate stiffness on the wall response as compared to a box-type distribution beam recommended by the ASTM Standard E 564.

Figure 10 shows the shear wall test setup. Table 3 summarizes the maximum loads and failure modes for both wall configurations. The first wall failed due to uplift degradation and developed resistance lower than that documented in the evaluation report. Both platform anchorage and wall anchorage were insufficient to resist uplift forces. The second wall failed due to panel rotation which was the failure mode intended by the evaluation report. The panel rotation also caused an uplift failure of the intermediate panel. Because the test specimen did not have gypsum panels on the interior surface, the maximum allowable load was 95 lb/ft lower than that documented in the evaluation report. The contribution of gypsum wallboard of approximately 100 lb/ft to the total allowable wall resistance is consistent with the provisions of the IBC⁸ and other sources of test data⁹. Thus, results of the testing were in a reasonable agreement with the data provided in the evaluation report. The same panel configurations were used with the demonstration house. The panel supplier was informed about the results and provided holddown devices at the building corners to improve the shear wall response to the level intended by the evaluation report and the standard test method used. Appendix A summarizes the engineering analysis of the shear walls in the demonstration house located in a high-wind area (wind speed of 130 mph based on 3-second gust).

⁸International Building Code (IBC), International Code Council (ICC), Inc., Falls Church, VA, 2000.

⁹Residential Structural Design Guide, 2000 Edition, U.S. Department of Housing and Urban Development, Washington (HUD), DC, 2000.

**TABLE 2
FASTENING SCHEDULE^{1,2}**

Connection	Fastener	Spacing	Notes
Panel to panel	#8 1/2-inch-long wafer head self-drilling screw	12 inches on center	Every panel has a one-inch-wide fastening tab that overlaps with the first stud of the adjacent panel The panels are connected through the tabs only on the exterior surfaces
Track to wall panel	#8 1/2 inch wafer head self-drilling screw	2 screws per stud on both sides	Same for both top and bottom track
Track to platform	#8 1 15/16-inch-long screws with countersunk 5/16-inch-diameter head	2 screws per 24 inches 1 screw in between	Each screw penetrates a platform joist
Clip angle to foundation	1/2-inch bolt with a 2-inch-diameter washer	4 feet on center	Four-foot on center spacing is a minimum requirement for 130 mph wind speed with Exposure B (Table R505.1(1), IRC 2000) The first bolt located 12 inches from the corner
Clip angle to rim joist	#10 3/4-inch-long hex head screws	5 per connection	
OSB to joist	#8 1 15/16-inch-long screws with countersunk 5/16-inch-diameter head	6 inches on center on perimeter and 10 inches on center in field	
Joist to rim joist	#10 3/4-inch-long hex head screws	3 per connection	Joists are connected through fastening tab which is a part of the rim joist
Joist to rim joist	#8 1/2-inch-long wafer head self-drilling screw	1 per connection	Joists are connected through the top flanges
Holddown restraint (Simpson S/HD8)	#10 3/4-inch-long hex head screws	24 per holddown	Wall 2 only, on uplifting corner only

¹For all connections screws extended through the steel member a minimum of three exposed threads.

²Edge distance of at least three diameters of the screw was used.

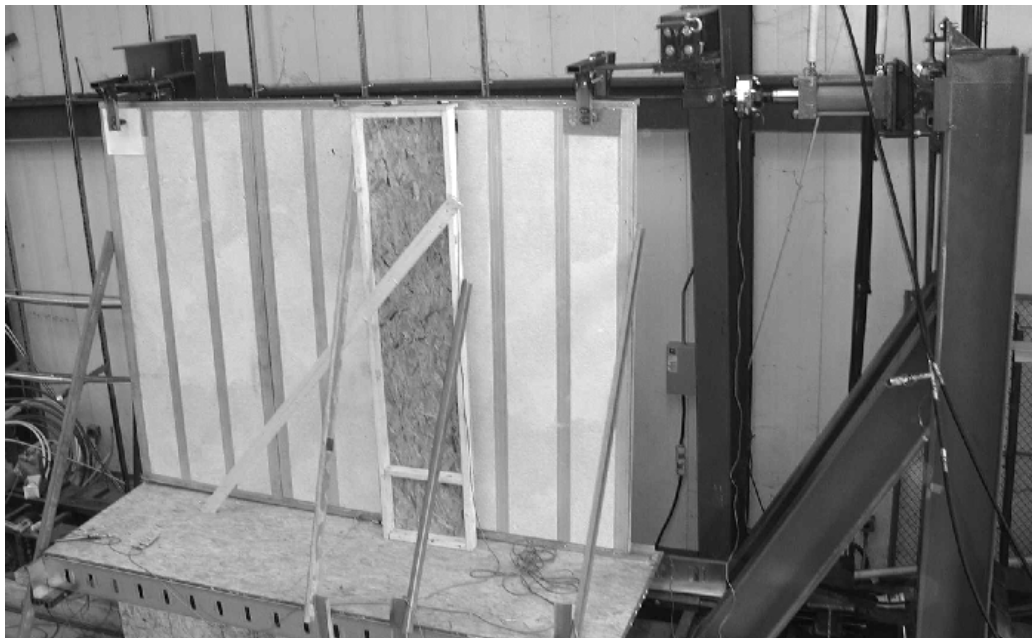

**Figure 10
Shear Wall Test Setup**

TABLE 3
SHEAR WALL PERFORMANCE PARAMETERS

Wall #	Peak Load, lb	Peak Unit Load, lb/ft	Allowable Unit Load ¹ , lb/ft	Failure Mode
Wall 1 (9' x 12')	3,530	294	118	Uplift failure of the platform anchorage and wall anchorage
Wall 2 (9' x 12')	6,486	540	216	Panel rotation and uplift of intermediate panel

¹Determined as peak load divided by a safety factor of 2.5.

Because both ASTM Standards, E 72 and E 564, were developed primarily based on experience accumulated on light-frame wood shear walls, they potentially lack the ability to address aspects of lateral response of nontraditional wall systems. In case of ThermaSteel™ panelized walls, wall length effects and panel uplift resistance can be overlooked by testing of only 8 foot by 8 foot wall segments in accordance with the ASTM Standards E 72 and E 564. To a similar degree, this concern is also relevant to various types of conventional wall systems.

The racking shear resistance of a light-frame wall is primarily provided by fasteners on the panel perimeter that resist individual panel rotation. Figure 11 shows fastening schedules used to assemble a traditional light-frame wall and a ThermaSteel™ wall. The fastening schedule for traditional light-frame construction is independent of the wall length, whereas the relative amount of fasteners in vertical joints of a ThermaSteel™ wall per unit length of the wall, f , is a function of the wall length. Table 4 summarizes values of the parameter f for both wall construction systems for four wall lengths: 8 feet, 12 feet, 16 feet, and 20 feet. The results of this analysis demonstrate that testing of an 8 foot by 8 foot wall underestimates resistance of longer walls constructed using ThermaSteel™ panels if panel rotation is the primary failure mode. It should be noted that in a ThermaSteel™ shear wall the shear resistance is primarily provided by the fasteners in the vertical joints. The contribution of the fasteners that attach bottom and top tracks to the wall panels is limited due to low bending stiffness of the light-gage steel tracks. Such effects are not typically considered or detected when applying traditional test methods to innovative systems. For example, a 20-foot-long wall specimen can be tested to measure the shear resistance of ThermaSteel™ walls instead of an 8-foot-long specimen to obtain more accurate design values for this particular wall configuration.

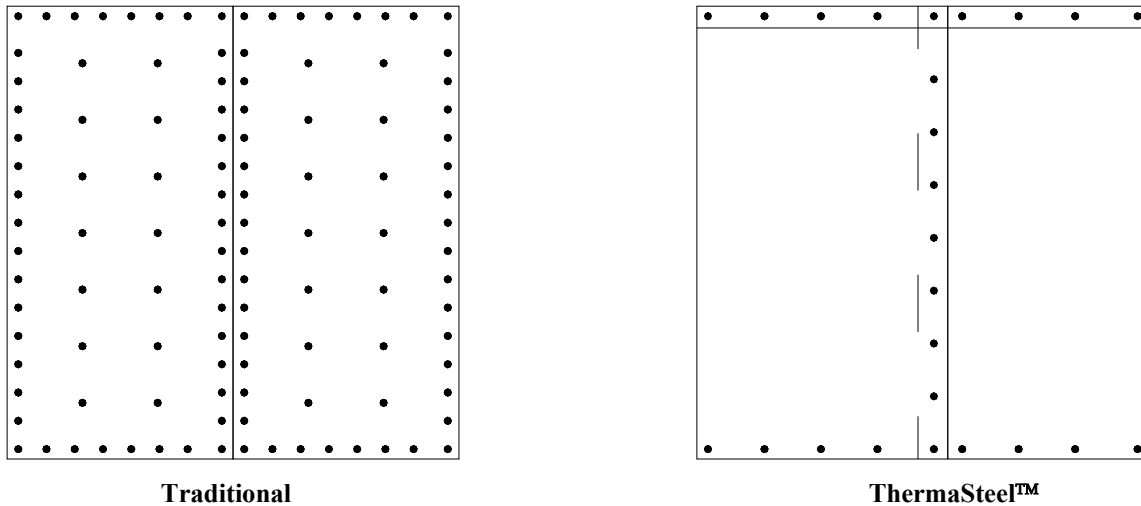

Figure 11
Sheathing Fastening Schedules for Traditional
and ThermaSteel™ Construction

TABLE 4
LENGTH EFFECTS COMPARISON FOR TRADITIONAL
AND THERMASTEEL® SHEAR WALLS

Number of panels in a wall, N	$f = n/N, \%$		Maximum potential error, %
	n = number of fasteners in a wall as a percentage of fasteners in a singles panel (vertical joints only)		
	N = number of panels in a wall		
	Traditional Construction, $f_1, \%$	ThermaSteel™ Construction, $f_2, \%$	
2 (8 feet)	100	50	50
3 (12 feet)	100	67	33
4 (16 feet)	100	75	25
5 (20 feet)	100	80	20

Another difference between the traditional light-frame and ThermaSteel™ systems is also associated with the sheathing fastening methods along the intermediate vertical joints. In a traditional light-frame wall, an intermediate stud which receives nails from two adjacent panels experiences minimal vertical load because the sheathing fasteners of the left and right panels counteract each other. In a ThermaSteel™ wall, there is only one vertical row of fasteners and the uplift force in the intermediate joint is not counteracted by the adjacent panel. Unless this uplift force is resisted by other means, it can create a weak link in the system. Therefore, an adequate uplift connection should be provided for each individual panel of a wall constructed using ThermaSteel™ system when greater capacity is needed for high shear load application.

The uplift restraint provided for Wall 2 was insufficient to prevent an uplift failure of an intermediate panel (Figure 12). However, if the wall were loaded with a stiff box-beam according to the ASTM Standard E 564, the beam would suppress this failure mode by restricting relative rotation of the adjacent panels. Therefore, loading shear walls with a flexible strap provides a more conservative method of testing that allows for a wider spectrum of failure modes that may be representative of actual construction depending on the boundary conditions of the wall (i.e., stiffness of the above platform, gravity load, etc.).

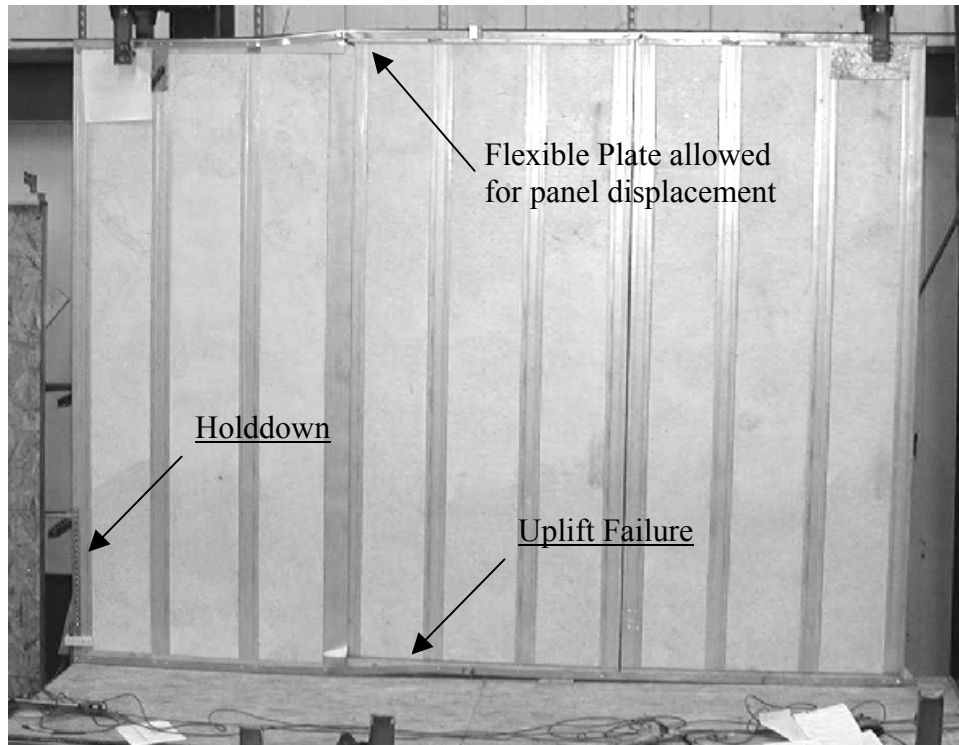

Figure 12
Failure Mode of Wall 2

Summary and Conclusions

Case Study I evaluated the management, design, building code approval, fabrication, and installation practices for a proprietary cold-formed steel panelized wall system in a hurricane-prone region. Conclusions and summary statements:

1. Implementation of improved management and organization practices is integral to success of engineered panelized wall systems in the residential construction market;
2. Technical and regulatory inconsistencies in the evaluation process between the code approval agencies can create a barrier to effective development and usage of innovative panelized wall systems;
3. Because the demonstration site is located in a hurricane-prone area, a licensed structural engineer was hired to verify the building performance. The degree of the engineer's involvement was determined by the local building authority;
4. Scope and limitations of the code evaluation process for establishing unit shear values for proprietary wall systems should be better communicated to the product user in relation to design decisions and applications. Testing standards and evaluation procedures developed for or based on traditional construction methods should be reviewed for applicability to nontraditional systems;
5. Independent regular periodic audits are recommended for the proprietary construction systems to assure the product quality and performance intended by the building code evaluation reports;
6. A flexible manufacturing process can allow for fabrication of a variety of panel configurations that meet complex architectural specifications for custom-built houses;
7. On-site wall construction using panelized systems is simplified and accelerated for reduced labor and time demand in the structural installation stage.

CASE STUDY II – LIGHT-FRAME WOOD PANELIZED CONSTRUCTION

Introduction and Objectives

This case study investigated light-frame wood panelized wall construction in a high seismic region (Seattle, WA, area). The specific objective was to evaluate the process of implementing innovative engineered panelized shear wall configurations within the existing building code regulation. In particular, shear walls with truss plate enhancements were investigated.

The scope of this report is limited to the wall panel design, building design, and obtaining the local building code approval. The building construction is underway and will be documented and evaluated in a followup PATH field evaluation report. However, some of the manufacturing and construction methods are presented based on the typical practices used by the parties involved in this demonstration project.

Roles and Responsibilities

A flow-chart (Figure 13) shows the parties involved in the project and relationships between the parties. Table 5 summarizes responsibilities of each party as observed during the project. The building construction process was managed by the builder (Quadrant Homes, Bellevue, WA) whose responsibilities included acquiring the land, hiring subcontractors, and obtaining the building permit. The builder also developed building plans that incorporated specifications provided by the panel manufacturer and wall designer.

The panel manufacturer (Woodinville Lumber, Woodinville, WA) prepared wall panel shop drawings for each individual panel in the building based on design specifications provided by the wall designer. The wall designer (independent engineering company) was employed by the builder to analyze the lateral force resisting system of the house.

As a typical construction practice used by *Woodinville Lumber*, the framing part of the building project is completed as a turnkey service through designing, manufacturing or supplying, and installing structural framing components including wall panels, roof trusses, floor joists, and sheathing products. The on-site framing is performed by a construction crew that is a part of the panel manufacturer construction division. Because the on-site framers are employed by the panel manufacturer, they comply with the company's quality and safety procedures providing an on-site extension of the in-factory production process. This practice allows for improved management of the entire framing construction process from material purchase to on-site framing inspection by the local building official.

The NAHB Research Center performed an evaluation function of the panelized wall construction process. The lateral analysis of the demonstration building was performed using innovative engineering methods. Moreover, novel truss plate enhancements were developed to improve on-site constructibility of the wall panels while maintaining or enhancing structural performance as required by the building code.

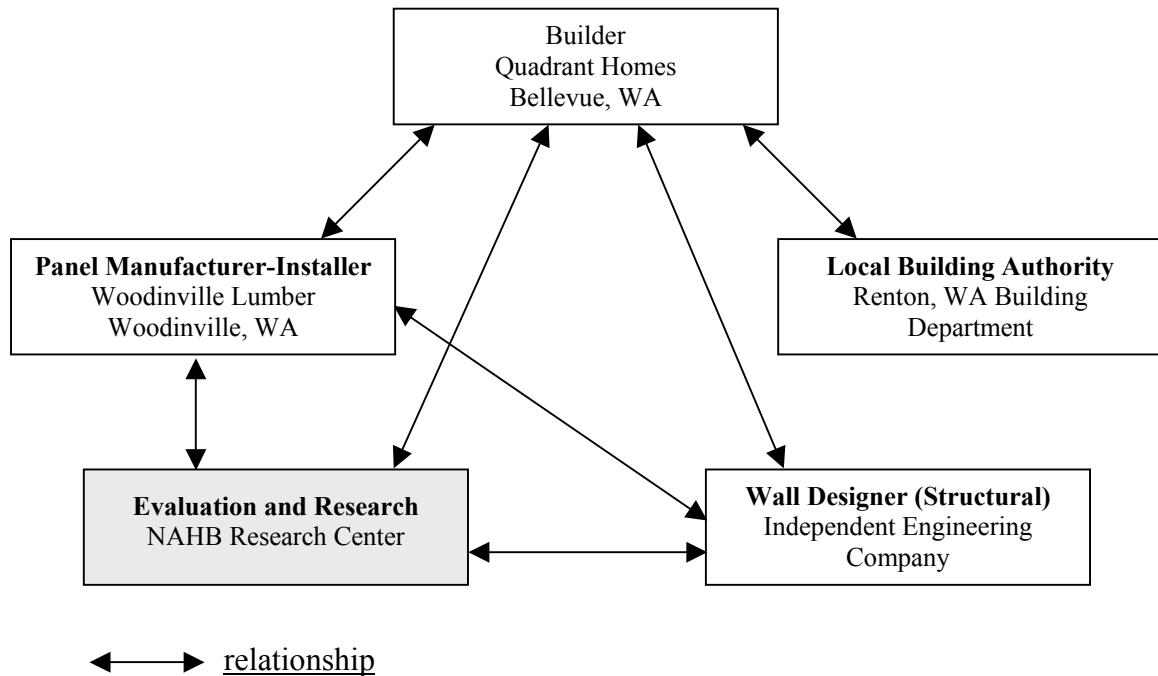

Figure 13
Case Study II – Project Team

TABLE 5
RESPONSIBILITIES OF PARTIES

Party	Description of functions
Builder	<ul style="list-style-type: none"> - Management of the construction process including hiring of subcontractors and obtaining building code approval - Performed architectural design and provided building plans
Panel Manufacturer - Installer	<ul style="list-style-type: none"> - Wall panel fabrication - Wall panel transportation and installation - Providing complete structural package including trusses, floor joists and sheathing, and framing lumber as a turnkey framing service - Provided panel shop drawings and customized the panel configurations to meet the building plan provided by the Builder - Performed truss design
Wall Designer (Structural)	<ul style="list-style-type: none"> - Performed structural design of lateral force resisting system using methods proposed by the NAHB Research Center as a basis
Local Building Authority	<ul style="list-style-type: none"> - Reviewed engineering calculations, performed quality inspections and enforced building code compliance
NAHB Research Center	<ul style="list-style-type: none"> - Performed evaluation function of the wall design, fabrication, and installation - Designed lateral force resistance system of the demonstration house - Developed shear wall enhancements using metal truss plates

Excluding the NAHB Research Center, four parties are involved in the wall construction process. In addition, both the builder and panel manufacturer have in-house design divisions. The panel manufacturer plays an integral role in the wall construction process through providing the design specifications, and the fabrication and construction services. Although the panel manufacturer is not directly involved into the building code approval process, the part of the building permit

application that covers wall construction is prepared based on the technical information developed by or prepared for the panel manufacturer.

Panelized Wall System

The demonstration building will be constructed using light-frame wood wall panels (Figure 14) fabricated in a factory by the panel manufacturer. The wall panels are fabricated as “open” assemblies that can be inspected on-site after installation. A wall panel is assembled with dimension lumber, structural sheathing panels, fasteners, and supplemental hardware. The framing members form a vertical load path that resists gravity loads and provide nailing surface for sheathing panels. The sheathing panels provide racking shear resistance and lateral support for framing members. The fasteners interconnect framing members, connect sheathing to framing, and connect wall panels to each other and to other building assemblies. Supplemental hardware, used to improve the wall performance and to provide overturning restraints, are typically installed in the field.



Figure 14
Fabrication of Light-Frame Wall Panels

The wall framing components include: studs, top and bottom plates, cripple studs under and above openings, window sill plates, and headers. Wall framing members are manufactured with 2- or 3-inch-thick and 4- or 6-inch-wide nominal size lumber. However, the vast majority of walls are made with 2 x 4 inch dimension lumber. To improve quality of the wall panels, *Woodinville Lumber* uses finger-jointed studs that have fewer defects and are more dimensionally stable as compared to solid-sawn lumber. Although the panel manufacturer pays a premium for the finger-jointed studs, the improved quality allows for simplifying the framing process and reducing the number of callbacks regarding the building framing. Both these factors offset the increase in the initial cost through preventing disruption of the construction process flow. The continuous flow is an important attribute of a successful panelized construction technology which consists of a series of consecutive operations requiring full completion of each preceding step.

Light-frame walls are sheathed with structural panel products. Depending on the end-use conditions, the building codes allow for various sheathing products such as OSB, plywood, gypsum, particleboard, fiberboard, hardboard, plaster, etc. However, in the high seismic areas the building codes typically require the use of wood structural panel products such as OSB or plywood.

The panelized wall practices vary between construction companies with respect to the degree of panelization of the house. All walls in a house, including exterior walls and interior bearing and nonbearing partitions, can be manufactured with prefabricated panels. An alternative practice is to panelize only exterior walls and fabricate the interior partitions on site. *Woodinville Lumber* uses the first approach so that the on-site framing operations are minimized and the responsibilities of the framing crew are limited to the panel assembly operations. As a typical method of construction in seismic hazard regions, such as Seattle, WA, all exterior wall panels are braced with structural wood sheathing and perform as shear walls. The interior wall panels are sheathed only with gypsum wallboard after the panel installation and framing inspection. However, if structural analysis indicates that the resistance provided by exterior shear walls is insufficient for a given set of loading conditions, the engineer can specify certain interior partitions to be constructed as shear walls.

In the demonstration house, the wall panels are designed to be enhanced with truss plates (installed at the plant) located at the corners and around openings. The second story walls are designed with integral overturning restraints that use a combined response of metal truss plates and anchor bolts with plate washers to resist overturning moment. A detailed description of these enhancements including engineering calculations and verification testing are provided in the *Structural Evaluation and Testing* section and Appendix B. This design approach is intended to add only minor hardware installation during manufacturing and to minimize hardware coordination and installation in the field.

Demonstration Site

The demonstration house will be built in a new development in Renton, WA. This region is considered as a seismic prone area and is assigned to a Seismic Category 3 in accordance with the 1997 UBC¹⁰. Figure 15 is a photograph of a building of the same model as the future demonstration house. This is a two-story single-family home constructed on a reinforced concrete stem wall foundation with a crawl space. The building plan dimensions are 40 feet by 43 feet and maximum roof height is 27.5 feet from the ground level. The roof system uses gable forms with 6:12 pitch.

The house is built using platform construction. The floor platforms consist of prefabricated I-joist sheathed with 3/4-inch-thick plywood subfloor nailed and glued to the top flange of the joists. The walls are assembled with prefabricated wall panels and drywall is applied on the interior wall face after the framing inspection. The roof is framed with prefabricated metal plate connected wood trusses sheathed with 7/16-inch-thick OSB panels.

¹⁰Uniform Building Code (UBC), International Conference of Building Officials (ICBO), Whittier, CA, 1997.



Figure 15
Case Study II: Replica of Demonstration House

Regulatory Approval Process

Building construction in the State of Washington is regulated by the Washington State Building Code (WSBC). The 1997 UBC is adopted by the State of Washington and is included in the provisions of the WSBC by reference. Although the 1997 UBC permits the use of prescriptive construction provisions for single-family houses in the Seattle area, the local building authority requires that each building plan is reviewed by a licensed professional. Thus, the panel manufacturer employed services of an independent engineering company that performed lateral analysis of the walls of the demonstration house. The engineer designed roof and floor diaphragms and shear walls. As a basis for the design of shear walls, the engineer used a proposal prepared by the NAHB Research Center (Appendix B). The proposal was developed based on innovative design and construction methods, that were not directly addressed in the 1997 UBC. The NAHB Research Center provided a detailed engineering substantiation for the proposed methods as *Alternate materials, alternate design and methods of construction* specified in Section 104.2.8 of the 1997 UBC. This substantiation included engineering calculations, references to model building codes, regulatory documents, research reports, and results of full-scale testing.

While the demonstration house was planned to be built in Snohomish County of Washington State, the representatives of the NAHB Research Center had a meeting with the officials from the Snohomish County Building Department. The objectives of this meeting were to present the demonstration project, provide substantiation for the proposed design options, and obtain feedback from the building officials in respect to the use of the alternate design and construction clause of the building code and the degree of the expected substantiation. The building officials welcomed the idea of implementing innovative engineering methods and were satisfied with the level of substantiation provided by the NAHB Research Center. However, the building officials emphasized that the proposal should be reviewed by an independent engineer licensed in the State of Washington. Because Quadrant Homes later exhausted their land reserve in Snohomish

County before the project was finalized, the demonstration site was relocated to Renton, WA. The proposal was submitted to the local building department as a part of a building permit application prepared by the builder. The building permit was issued on December 7, 2001.

Lateral Force Design Methods

As described in Case Study I, light-frame buildings resist lateral forces resulting from wind and seismic events through a system of diaphragms and shear walls. Discussions of the methods of lateral force distribution and determination of shear wall resistance are provided in the *Model Guidelines for Design, Fabrication, and Installation of Engineered Panelized Walls* (HUD 2002) and Case Study I. In this section, aspects of seismic lateral analysis relevant to the design procedures used with the Case Study II demonstration house are discussed.

The concept of a continuous load path presented in Case Study I is particularly important in seismic design. To dissipate high seismic energy, the building should be designed such that yielding of some structural members occurs during a design level earthquake. Therefore, these structural members experience forces approaching the maximum strength (capacity) and the building can sustain both structural and nonstructural damages. The philosophy of seismic design is to provide the structure with high overall ductility so that the seismic energy can be dissipated and catastrophic failure modes are suppressed. To achieve this goal, the engineer should properly detail the structural components and connection using capacity as a design basis. However, the traditional design methods for light-frame construction use other limit states, such as allowable load with uncertain safety margins or deflection criteria, to establish design resistance values. This conflict between the seismic design philosophy and traditional wood design procedures can result in inefficient design solutions. While the analysis of the demonstration home (Appendix B) is conducted according to the provisions of the 1997 UBC, which follow the traditional design format, the overturning restraints are analyzed using capacity of shear walls and capacity of individual connections as a design basis. This type of analysis allowed for incorporating a balanced seismic load path and for development of economical connection solutions.

Panel Fabrication

The wall panels will be fabricated by *Woodinville Lumber* in accordance with detailed shop drawings prepared by an internal design department based on architectural specifications provided by the builder and engineering calculations provided by the wall designer. An individual shop drawing is developed for each wall panel in the building. Each wall panel is identified using a unique label which is cross-referenced to the building plan. Including interior partitions, a total of 64 shop drawings has been prepared for the demonstration house. A shop drawing includes overall panel dimensions, layout of framing members, layout of sheathing panels, reference to the building plan, and panel label.

The fabrication of wall panels is organized in a linear production process (Figure 16) as follows:

1. lumber is precut using automatic computer sawing system based on the specification from the shop drawings;
2. sheathing panels are precut to the shop drawing specifications;
3. precut components are arranged on the framing table to form a designed wall configuration and nailed together by the framers using pneumatic nail guns (Figure 17);

4. precut sheathing panels are positioned at the design locations and nailed to framing along the bottom and top plates and cripple studs (Figure 18);
5. sheathing panel edges around wall panel openings are machined with a router to provide square openings ready for installation of doors and windows (Figure 19);
6. the remaining sheathing nails are installed using a multiple nail gun rack (Figure 20);
7. finished panels are hoisted from the production line, stacked, and held together with metal strapping (Figure 21).



Figure 16
Wall Panel Production Line



Figure 17
Wall Panel Being Framed



Figure 18
Application of Sheathing Panels



Figure 19
Machining of Panel Openings



Figure 20
Multiple Nail Gun Rack for Attaching Sheathing Panels



Figure 21
Panel Handling and Packaging

This process organization enables implementation of methods of mass production to light-frame wall construction. The framing process is accelerated and optimized for more efficient use of labor, materials, and equipment. The controlled factory environment allows for implementation of heavy-duty stationary equipment such as the computerized saw and multiple gun nailer. The use of computer-aided sawing operations for production of framing components minimizes lumber waste and simplifies framing. The wall assemblies are moved along the production line on a system of rollers and stacked using a hoist eliminating heavy labor from the fabrication process. Storage of materials, production operations, and storage of finished product occur under roof to minimize exposure the environment.

For production of wall panels with metal truss plates, as proposed for the demonstration house, an operation for installation of the truss plates will be added to the production sequence. A

station with a portable c-clamp press will be located between the framing and sheathing stations of the production line. The press will be used to embed metal truss plates into both faces of the framing assemblies before the sheathing installation. In addition, this station can be used to install holddowns on the first story wall panels as designed in Appendix B. This phase of the panel manufacturing will be evaluated and documented in a followup PATH field evaluation report.

Panel Transportation and Installation

The process of panel transportation and installation will be evaluated and documented in a followup PATH field evaluation report.

Structural Evaluation of Shear Walls

As a typical practice used with stick-built construction to provide overturning restraints for second story walls, the wall designer specifies light-gage steel straps that are installed during on-site construction (Figure 22). These straps should be nailed directly onto the studs and the sheathing panels should be applied in a subsequent operation. This practice interferes with the panel production sequence which includes the sheathing panel installation as a part of the in-factory process.

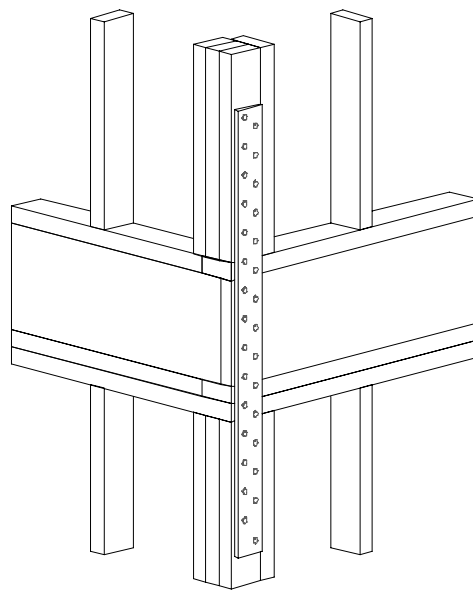

Figure 22
Typical Site-Built Strap Installation

To resolve this problem, the panel manufacturer precuts sheathing panels in the factory to provide a continuous nailing surface for the straps (Figure 23). However, this solution weakens shear walls due to the removed nails at the panel corners where the shear stress is maximum. Moreover, the precutting of the panels introduces an additional step in the panel manufacturing sequence without adding value to the final product to offset the associated costs.

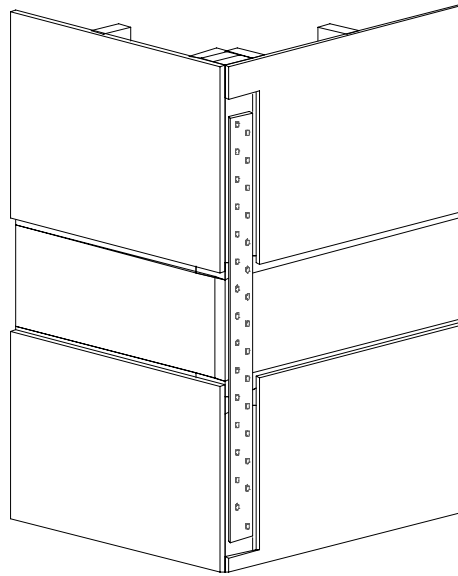

Figure 23
Strap Installation on Panelized Walls with Precut Sheathing Panels

Installation of these straps on the exterior surfaces of the second story walls should be performed from the outside of the building because the access from the inside of the building is blocked by the sheathing. This operation is labor and time consuming and requires additional safety measures for the framers working on the second story level.

To secure the first story walls to the foundation, the wall designer specifies similar straps that have one end embedded into the concrete foundation. The straps are installed during the foundation construction and nailed to the studs after the wall panels are positioned in place. The sheathing panels are precut in a similar manner to accommodate the straps. As a result, the corner studs of the first story walls can lack as much as a third of the sheathing nails due to installation of the straps.

In addition, the strap can buckle out of its plane (Figure 24) due to wood shrinkage after the frame members reach the in-service equilibrium moisture content and due to settlement of the house structure. The strap buckling appears as a bulge on the exterior siding. This is primarily a cosmetic defect, yet it requires an extensive structural repair to restore the original siding appearance. It can also create undesirable “slack” in the lateral force resisting system.

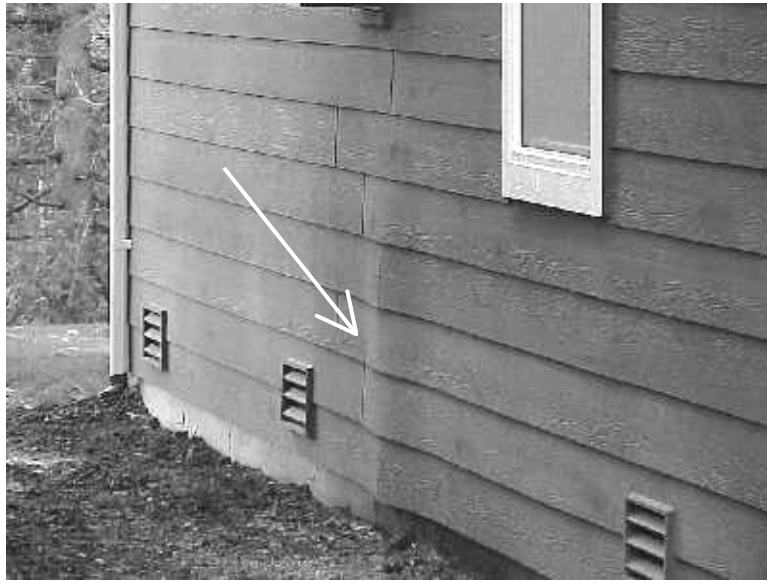

Figure 24
Buckled Holddown Strap

The problem is further aggravated by the fact that the 1997 UBC allows only the segmented shear wall construction which requires holddowns at the wall corners and around all windows or doors. For example, according to segmented shear wall method, the first story of the standard plan identical to the demonstration house typically requires as many as 26 holddowns.

The NAHB Research Center proposed a series of structural solutions to mitigate the discussed problems with the nail-on straps. The first story straps can be replaced with holddown brackets that are installed inside the wall cavity and bolted to the foundation with anchor bolts. The on-site installation of this type of holddown can be difficult and time-consuming due to the short distance between the corner stud and the second stud (12 inches or less) that limits the access to the holddown. The framer can be forced to drive nails manually because a regular-size nail gun does not fit between the studs. Moreover, the framer may have to drive the nails at an angle to get a sufficient hammer swing. Alternatively, this bracket can be easily installed on the corner stud in the factory before the framing components are assembled into the panel. On a construction site, the framing crew only needs to install a threaded rod and attach it to the foundation bolt using a coupling nut. This approach simplifies and accelerates the wall panel assembly process as compared to traditional method of installation of the holddown devices after the wall panels are positioned in place.

As another solution, the number of holddowns can be reduced by using the perforated shear wall method for analysis of lateral wall resistance. According to this method, the overturning restraints are only required at the building corners (see *Model Guidelines for Design, Installation, and Construction of Engineered Panelized Walls* (HUD 2002) for description of the perforated shear wall method). For example, the number of holddowns in the first story of the demonstration building is reduced from 26 to 11 while maintaining required structural performance.

The straps between the first and second stories can be replaced with integral truss-plate holddowns that utilize combined resistance of truss plates and a bolt with a square plate washer.

Figure 25 depicts one configuration of such a holddown device. The uplift force developed in the corner stud due to in-plane shear load is transferred to the wall bottom plate through metal truss plates installed on both faces of the framing. To provide truss plate contact area sufficient to resist the design uplift forces, a double bottom plate can be used at the location of the truss plate. The bottom plate acts as a short cantilever beam loaded with a single point load at the end. The addition of the second bottom plate also reduces the bending stress by increasing the area of the bending cross section. To minimize the bending moment, the bolt is located within 8 inches from the corner as opposed to typical 12 inches. A plate washer is installed with the anchor bolt to prevent a cross grain failure of the bottom plate.

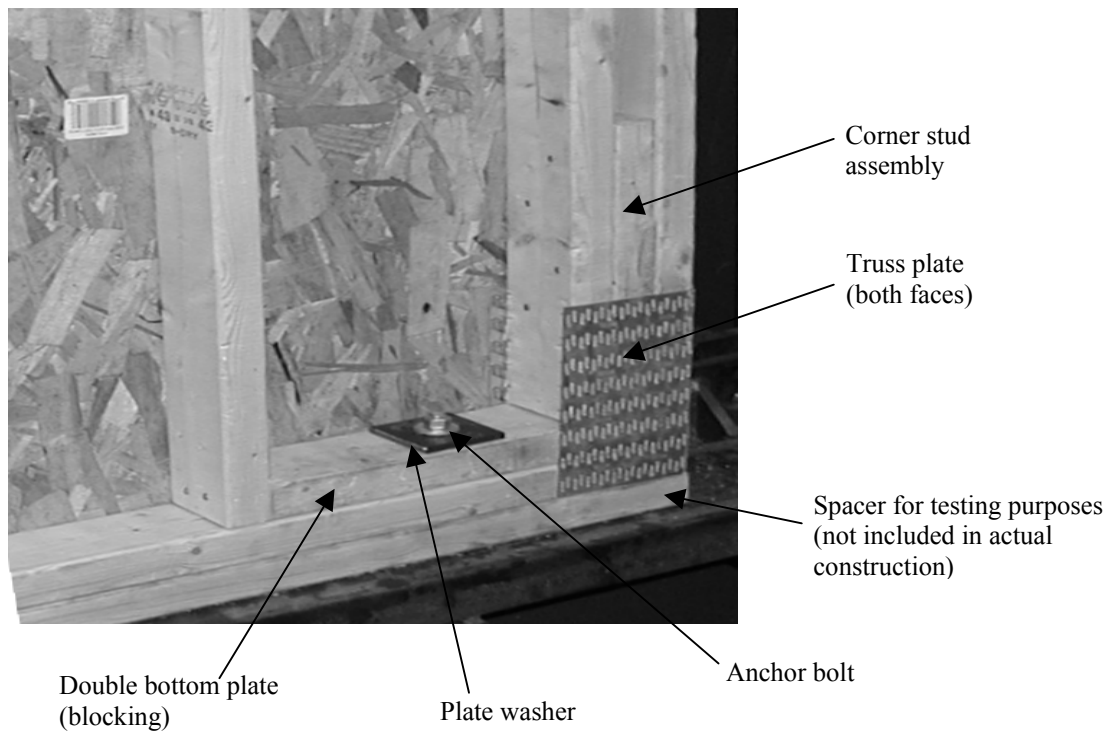

Figure 25
Truss Plate Holddown

Testing of Integral Truss Plate Holddown

To substantiate the proposed holddown configuration, a full-scale shear wall was tested. The objective of the test was to measure the resistance of the truss plate holddown and compare results of the test with the analytical predictions. This test was conducted in addition to prior testing of shear walls reinforced with metal truss plates¹¹.

An 8 foot by 12 foot shear wall with a door opening (Figure 26) was tested to destruction using a monotonic loading history. The same test setup and test methods as described in Case Study I were used. Load was applied in tension with a 0.25-inch-thick strap. The general guidelines of the ASTM Standard E 564 were followed.

¹¹The Performance of Perforated Shear Walls with Narrow Wall Segments, Reduced Base Restraints, and Alternative Framing Methods, U.S. Department of Housing and Urban Development, Washington, DC, 1998.

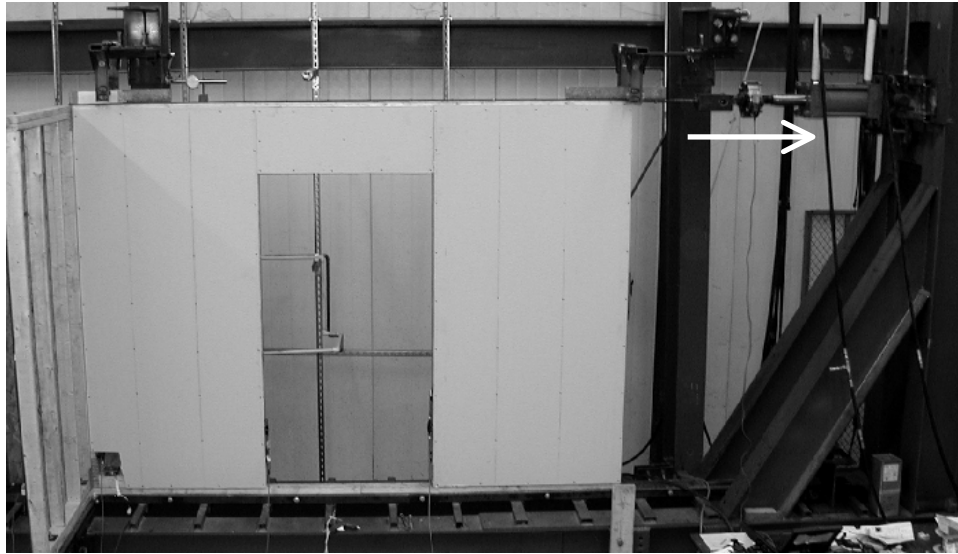

Figure 26
Test Wall Configuration and Test Setup

The wall was framed with 2 x 4 inch nominal Spruce-Pine-Fir (SPF) Stud grade lumber and sheathed with 7/16-inch-thick OSB panels. Because the uplift force is a function of the shear resistance of the wall, ½-inch-thick gypsum wallboard panels were installed on the interior wall face to increase the shear wall strength and, therefore, the uplift force applied to the holddown. A 4 foot by 8 foot corner segment was constructed on the uplifting end of the wall. Fastener types and schedule used to frame the wall are summarized in Table 6.

TABLE 6
FASTENING SCHEDULE

Connection	Fastener¹	Spacing
Top plate to top plate (face-nailed)	16d pneumatic nails	12 inches on center
Top plate to top plate lap connection at the corner	3-16d pneumatic nails	per connection
Top/bottom plate to stud (end-nailed)	2-16d pneumatic nails	per connection
Stud to stud (face-nailed)	2-16d pneumatic nails	24 inches on center
Stud to window sill plate and header (end-nailed)	2-16d pneumatic	per stud
Bottom plate to platform	½-inch anchor bolts with 3 x 3 x 0.25 inch plate washer	4 feet on center
Corner return to wall end stud	16d pneumatic nails	24 inches on center
OSB sheathing panels to framing	8d common nails	4 inches on perimeter 12 inches in field
Gypsum wallboard panels to framing	# 6 screws	12 inches

¹16d pneumatic nail: D = 0.131 inch, L = 3-1/4 inch

8d common nail: D = 0.131 inch, L = 2.5 inch

M II 20 metal truss plates¹² manufactured by MiTek Industries Inc. were installed at wall corners and around door opening on both faces of the framing members (Figure 27). The truss plates were embedded into wood framing members individually using a sledge hammer. A technician hit a 5/8-inch-thick steel plate positioned on top of a truss plate with the sledge hammer until a

¹²Evaluation Report ER-4922, International Conference of Building Officials (ICBO), 1999.

full contact of the truss plate and the framing members was achieved. Five inch by eight inch truss plates were installed at the exterior corners and at the header, whereas three inch by six inch truss plates were installed at the other corners.



Figure 27
Wall Framing with Truss Plates

Figure 28 depicts arrangement of framing members at the wall corner. To accommodate the double bottom plate, the second stud is precut to a length 1.5 inches shorter than regular studs. The total truss plate contact area on one face of the double bottom plate is 12.75 inches. The allowable lateral resistance value for M II 20 MiTech truss plates installed in SPF lumber on both member faces is 137 lb/in². Because the truss plate is installed on the narrow face of the bottom plate, the allowable resistance should be reduced with an adjustment factor of 0.85. To estimate the maximum resistance of a truss plate connection, the allowable value should be multiplied by a factor of 3.2¹³. Therefore, the target maximum resistance of the truss plate holddown is:

$$HR = (137 \text{ psi}) (0.85) (3.2) (12.75 \text{ in}^2) = 4,751 \text{ lb}$$



A. Before Plate Installation

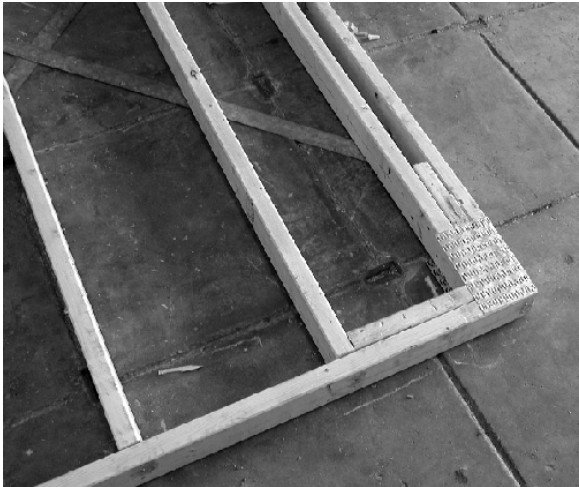

B. After Plate Installation

Figure 28
Arrangement of Framing Members at the Wall Corner

¹³National Design Standard for Metal Plate Connected Wood Truss Construction, ANSI/TPI 1-1995, Truss Plate Institute (TPI), 1995.

The resistance of the holddown was measured with a ring-shaped load cell placed on the anchor bolt between the plate washer and a steel plate (Figure 29). The corner of the gypsum panel was cut off to allow for observing the holddown behavior during the test. Two additional screws were installed around the opening to compensate for the lack of the corner screw. The anchor bolt was tightened snug to an initial tension load of around 70 lb.



Figure 29
Holddown Instrumentation

The maximum force resisted by the holddown was 5,377 lb (adjusted for the initial preload). The analytical method provided a conservative estimate (4,751 lb) of the holddown resistance with an error of 11.6 percent. A conservative error of this magnitude is generally considered as a reasonable level of accuracy for full-scale verification testing. Therefore, the presented analytical procedure is valid for calculating the resistance of the integral truss plate holddown. The testing demonstrated that the truss plate holddown can be successfully used to resist uplift forces within the range of loads predicted with the proposed analytical method. Therefore, this type of overturning restraint, but with a greater truss plate contact area, is proposed for the second story shear walls of the demonstration house. The engineering calculations for the demonstration site (Appendix B) use the proposed design method to determine the resistance of the truss plate holddowns.

Summary and Conclusions

Case Study II evaluated the management, design, building code approval, fabrication, and installation practices for a light-frame wood panelized wall system in a high seismic area. Conclusions and summary statements follow in the order the subject matter was discussed in the report:

1. Panelized wall technology excels within the construction environment that uses a system approach in design, fabrication, and installation of the house structure. Recognizing this opportunity, the panel manufacturer offers a turnkey service for construction of the house structure providing the customer with a “one-stop” framing solution.

2. Building approval for innovative design and construction methods can be obtained by using the *Alternate materials, alternate design and methods of construction* clause of the building code. The case study demonstrated that the building authority welcomed the alternate design and construction approach provided that reasonable substantiation was submitted and the engineering calculations were verified by a licensed engineer.
3. Lateral analysis procedures that use capacity as a design basis provide design solutions that are more consistent with the formulation assumptions for seismic design methodologies and can result in more economical structural solutions.
4. In-factory panel fabrication can be accelerated and optimized through the use of an efficient streamlined production process and heavy-duty stationary equipment. The fabrication process can include operations for installation of engineered hardware as a part of the in-factory wall assembly production.
5. Wall design can be optimized to simplify the on-site installation of prefabricated panels by implementing innovative design and construction methods developed through research and engineering. These novel methods can be incorporated into the panelized wall technology process to obtain structural framing solutions that meet the performance-based building code criteria.

PROJECT SUMMARY AND CONCLUSIONS

As demonstrated throughout the case studies, the panelized wall technology is a viable and advantageous method of light-frame construction that can promote affordability, quality, and structural safety of housing. The panelized wall construction process is described in detail using two construction sites to independently assess this technology and identify opportunities to advance the current practice.

While the scope of this project includes all types of panelized walls, the focus of the study is the structural load bearing walls which can benefit most from the engineered panelized wall technology. As an integral part of the lateral force resisting system, shear walls are scrutinized with respect to panelized construction to investigate the technical challenges involved in the code approval and structural design process associated with their implementation in high seismic and hurricane-prone regions. Where appropriate, recommendations and innovative design solutions are provided for improved technology and structural performance of panelized shear walls.

The case studies manifest the benefits of panelized wall construction and identify regulatory and technical barriers to a wider acceptance and more effective use of panelized building technology. Analysis of information accumulated from the case studies indicates that a successful panelized construction system needs improved organization and management practices that provide a concerted effort from all parties involved in the building process: building designer, wall designer, wall manufacturer, builder, and governing building authority. The implementation of such practices requires a defined system of responsibilities and functions for each party and improved quality control procedures for wall design, fabrication, transportation, and installation. Currently, there is no comprehensive standardized regulatory document that defines policies and procedures for directing the panelized wall construction process.

The existing regulatory approval process lacks a systematic guideline that can provide consistent acceptance criteria for novel engineered wall systems developed to meet the performance-based

requirements of the building codes. Moreover, the engineering design practices vary significantly among the building codes and practitioners, creating an additional obstacle for implementing innovative panelized wall systems consistently across the country.

Based on results of the case studies, it can be concluded that there is an opportunity for promotion of the improved residential construction practices through adoption of panelized wall technology by the housing and building component industries. As a means for overcoming the identified barriers, comprehensive *Model Guidelines for Design, Fabrication, and Installation of the Panelized Walls* (HUD 2002) have been developed by the NAHB Research Center. The goal of this new document is to begin the process of standardizing the construction practices used by the panelized wall industry and to establish a uniform basis for engineering design of wall systems and development of innovative wall configurations. This document should become a starting point for development of an industry standard, which through a reference in the building codes, regulates and promotes efficient panelized wall construction practices.

APPENDIX A
ANALYSIS OF THE LATERAL FORCE RESISTING SYSTEM OF THE
DEMONSTRATION HOUSE LOCATED IN BEAUFORT, SC (CASE STUDY I)

LOAD CALCULATION

At the time of the demonstration house construction, the Standard Building Code (SBC) was the governing building code in Beaufort County of the State of South Carolina. Therefore, this analysis is performed according to the SBC. The 1999 SBC permits the use of ASCE 7 for calculation of design wind loads. Therefore, ASCE 7-98 is used to determine design wind loads. Seismic analysis is not included in these calculations.

The design wind loads are determined using Method 2 - Analytical Procedure (Section 6.5). The building is beyond the scope of Method 1 - Simplified Procedure (Section 6.4) because it has roof slopes greater than 10° . The procedure for low-rise buildings is used.

1. Basic wind speed, V , and wind directionality factor, K_d .
 $V = 130$ mph (Figure 6.1)
 $K_d = 0.85$ main wind force resisting system (Table 6.6)
2. Importance factor, I .
 $I = 1.0$ (Table 6-1, Category I and $V > 100$ mph)
3. Exposure category and velocity pressure coefficient, K_z or K_h .
Exposure C is assumed because the terrain representative of Exposure B does not prevail in the west directions by 1,500 feet as required by section 6.5.6.1.
 $K_z = 0.85$ (Table 6.5, $z < 15$)
 $K_h = 0.92$ (Table 6.5, $h = 22$), the same K_h is used with all roof pressures
 $K_z = 0.87$ (Table 6.5, $z = 16.5$ - gable end of the front wall)
4. Enclosure classification.
The building is classified as partially enclosed because the building is located in the wind borne debris region (basic wind speed greater than 120 mph), and impact resistant glazing was not used. This classification does not affect lateral building load magnitude.
5. External pressure coefficients GC_{pf} , (Figure 6-4).

The coefficients are determined for roof angle range of 30-45 degrees

Wall windward

$$GC_{pf} = 0.56$$

Roof windward

$$GC_{pf} = 0.21$$

Roof leeward

$$GC_{pf} = -0.43$$

Wall leeward

$$GC_{pf} = -0.37$$

6. Velocity pressure q_h .

$$q_z = 0.00256 K_z K_{zt} K_d V^2 I = 0.00256 (0.85) (1.0) (0.85) (130)^2 (1.0) = 31.3 \text{ lb/ft}^2$$

$$q_h = 0.00256 K_h K_{zt} K_d V^2 I = 0.00256 (0.92) (1.0) (0.85) (130)^2 (1.0) = 33.8 \text{ lb/ft}^2$$

$$q_z = 0.00256 K_z K_{zt} K_d V^2 I = 0.00256 (0.87) (1.0) (0.85) (130)^2 (1.0) = 32.0 \text{ lb/ft}^2$$

7. Design wind load p .

$$p = q GC_p - q_i (GC_{pi})$$

Walls

Windward

$$p = (31.3)(0.56) = 17.5 \text{ lb/ft}^2$$

$$p = (32.0)(0.56) = 17.9 \text{ lb/ft}^2 - \text{gable end}$$

Leeward

$$p = (33.8)(-0.37) = -12.5 \text{ lb/ft}^2$$

Roof

Windward

$$p = (33.8)(0.21) = 7.1 \text{ lb/ft}^2$$

Leeward

$$p = (33.8)(-0.43) = -14.5 \text{ lb/ft}^2$$

8. Forces

The areas are estimated using AutoCAD software package from the drawings created based on building plans provided by the wall panel supplier.

NS direction

Projected roof area including gable ends

$$A = 1,289 \text{ ft}^2$$

Projected roof area without gable ends

$$A = 1,289 - (2)(141) = 1,007 \text{ ft}^2$$

Wall area including gable ends

$$A = (92)(9.1/2) + 282 = 701 \text{ ft}^2$$

Roof load

$$F = (1,007)(14.5 + 7.1) = 21,751 \text{ lb}$$

Wall load

$$F = (701)(17.9 + 12.5) = 21,310 \text{ lb}$$

Total load in NS direction

$$F = 21,751 + 21,310 = 43,061 \text{ lb}$$

EW direction

Projected roof area

$$\text{West side: } A = 222 + 412 = 634 \text{ ft}^2$$

$$\text{East side: } A = 175 + 477 = 652 \text{ ft}^2 - \text{governs}$$

Projected roof area of the hidden surface

$$A = 164 \text{ ft}^2$$

Wall area

$$A = (54.6)(9.1/2) = 248 \text{ ft}^2$$

Additional wall area from the hidden surface

$$A = (12)(9.1/2) = 55 \text{ ft}^2$$

Roof load

$$F = (652 + 164)(7.1 + 14.5) = 17,626 \text{ lb}$$

Wall Load

$$F = (248 + 55)(17.5 + 12.5) = 9,090 \text{ lb}$$

Total load in EW direction

$$F = 17,626 + 9,090 = 26,716 \text{ lb}$$

SHEAR WALL ANALYSIS

The rigid diaphragm method with torsion was used to distribute the total lateral load between the shear walls. The use of the rigid diaphragm method was justified due to the following: (1) ceiling diaphragm and roof diaphragm were sheathed with structural panels and interconnected at the joist-to-rafter joints with screws creating a box-type structure and (2) fifty percent of the total wind load (North-South direction) was received by roof diaphragm rather than walls. The reader is referred to *Model Guidelines for Design, Fabrication, and Installation of Engineered Panelized Walls* (HUD 2002) and Appendix C of this document for a more detailed description of the rigid diaphragm method.

Figure A1 shows a schematic plan of the building including location of shear walls. All exterior walls and garage walls are shear walls. The interior partitions are not shown, and their significant lateral strength contribution is ignored in this analysis as is typical to current design practice.

The shear wall capacity was calculated using the perforated shear wall method (see *Model Guidelines for Design, Fabrication, and Installation of Engineered Panelized Walls* (HUD 2002) for method description). The allowable shear design value of 311 lb/ft was used (Structural Engineering Bulletin No. 1072, HUD, 1997). Table A1 summarizes results of the shear wall design in the North-South (NS) direction. The allowable stress design format was used.

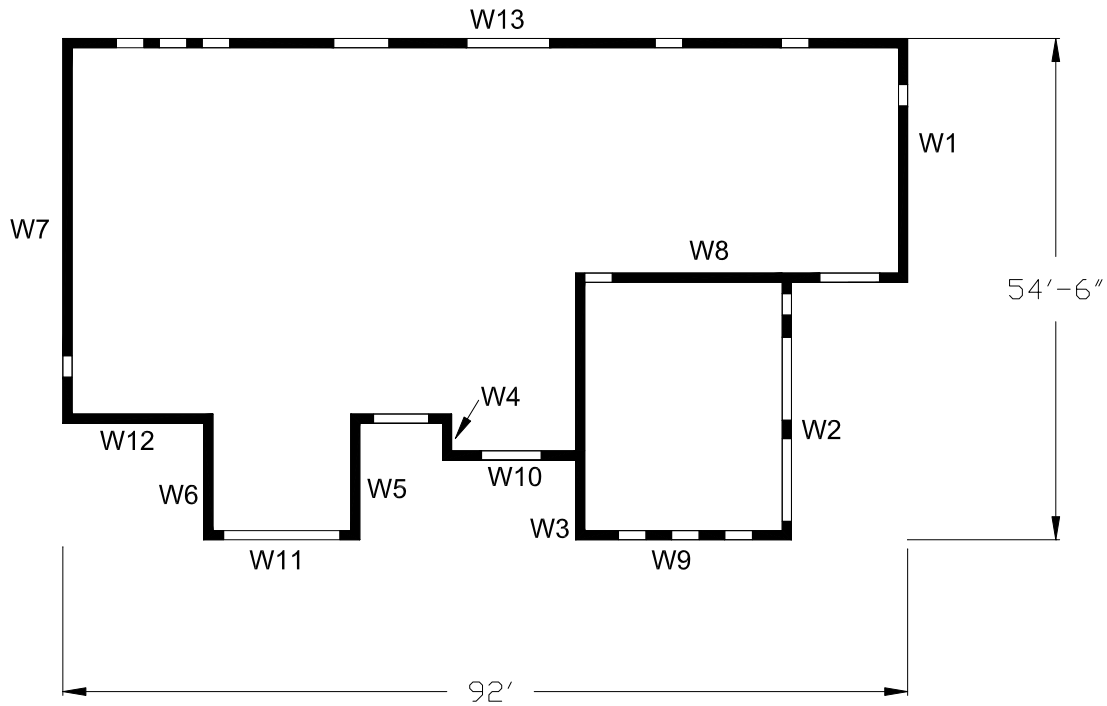

Figure A1
Shear Wall Schedule

TABLE A1
NS DIRECTION (EXPOSURE C)

Wall	Direct Shear Force, lb	Torsional Moment, lb-ft	Torsional Shear Force, lb	Total Shear Force, lb	Wall Resistance, lb	Check
		-300,175				
W1	8,257		2,102	10,359	6,955	Underdesigned
W2	0		0	0	0	Underdesigned
W3	10,371		878	11,249	8,736	Underdesigned
W4	1,574		29	1,603	1,326	Underdesigned
W5	4,538		-119	4,538	3,822	Underdesigned
W6	4,723		-492	4,723	3,978	Underdesigned
W7	13,598		-2,398	13,598	11,454	Underdesigned
Total	43,061					

While the results of the analysis indicate that shear walls of the demonstration building are underdesigned by as much as 49 percent (Wall 1) this finding must be tempered by judgement and a number of qualifying assumptions. As one qualifying assumption, the provisions of ASCE 7-98 specify wind exposure categories that are conservative in respect to the demonstration site conditions. If a more realistic Exposure B is assumed, then the total lateral load in NS direction is 29,756 lb (calculations are not shown) and Wall 1 is underdesigned by only 3 percent (Table A2) which is generally an acceptable margin for engineering safety checks.

**TABLE A2
NS DIRECTION (EXPOSURE B)**

Wall	Direct Shear Force, lb	Torsional Moment, lb-ft	Torsional Shear Force, lb	Total Shear Force, lb	Wall Resistance, lb	Check
		-207,427				
W1	5,706		1,452	7,158	6,955	Underdesigned
W2	0		0	0	0	OK
W3	7,167		607	7,773	8,736	OK
W4	1,088		20	1,108	1,326	OK
W5	3,136		-82	3,136	3,822	OK
W6	3,263		-340	3,263	3,978	OK
W7	9,397		-1,657	9,397	11,454	OK
Total	29,756					

In addition, the method for calculation of the design wind loads is based on gable roof configurations that provide conservative estimates for more aerodynamic hip roofs. Furthermore, including the effect of the partitions, dead load, and contribution of stucco siding will significantly increase the wall resistance relative to the analysis.

Tables A3 and A4 summarize results of the shear wall analysis in the East-West (EW) direction for Exposure categories C and B, respectively. The discussion in the previous paragraph is valid.

**TABLE A3
EW DIRECTION (EXPOSURE C)**

Wall	Direct Shear Force, lb	Torsional Moment, lb-ft	Torsional Shear Force, lb	Total Shear Force, lb	Wall Resistance, lb	Check
		-296,375				
W8	2,955		91	3,046	2,806	Underdesigned
W9	3,320		594	3,914	3,153	Underdesigned
W10	1,660		220	1,880	1,576	Underdesigned
W11	0		0	0	0	Underdesigned
W12	5,026		560	5,587	4,774	Underdesigned
W13	13,755		-1,466	13,755	13,063	Underdesigned
Total	26,716					

**TABLE A4
EW DIRECTION (EXPOSURE B)**

Wall	Direct Shear Force, lb	Torsional Moment, lb-ft	Torsional Shear Force, lb	Total Shear Force, lb	Wall Resistance, lb	Check
		-204,698				
W8	2,041		63	2,104	2,806	OK
W9	2,293		410	2,704	3,153	OK
W10	1,146		152	1,298	1,576	OK
W11	0		0	0	0	
W12	3,472		387	3,859	4,774	OK
W13	9,500		-1,012	9,500	13,063	OK
Total	18,452					

APPENDIX B
ANALYSIS OF THE LATERAL FORCE RESISTING SYSTEM OF THE
DEMONSTRATION HOUSE IN RENTON, WA (CASE STUDY II)

This appendix incorporates engineering calculations and technical substantiation prepared by the NAHB Research Center for submittal to the building code authority as a part of the complete building permit application package assembled by the builder.

INTRODUCTION

This proposal is a continuation of an ongoing project that was started as a task under the Partnership for Advanced Technology in Housing (PATH) program sponsored by the U.S. Department of Housing and Urban Development (HUD). The objective of this task is to bring innovative design and construction methods into the panelized wall industry to produce structural building systems that more efficiently meet performance requirements of existing building codes.

The following two sections of the report present the construction details and engineering calculations for the proposed design alternatives, respectively. The analysis is based on house Plan 2575 provided by Quadrant Homes, Bellevue, WA.

CONSTRUCTION DETAILS

This section presents shear wall schedule and anchorage requirements. In particular, the truss plate holddowns are described in detail.

Table B1 summarizes the shear wall construction and design characteristics as prescribed by the UBC-97 (Table 23-II-I-1).

TABLE B1
SHEAR WALL CONFIGURATIONS

Shear wall designation	Nailing schedule on panel edges	Design shear value ¹ , lb/ft	Construction details
P1-6	6 inches on center	230	<ul style="list-style-type: none"> • Nails: 8d common (0.131 inch in diameter and 2.5 inch long) or equivalent pneumatic • Nailing schedule in the panel field: 12 inches on center • Sheathing 7/16-inch-thick OSB on one side • SPF studs spaced 16 inches on center • Top and bottom plates: Hem-Fir lumber
P1-4	4 inches on center	352	

¹Design shear values include applicable adjustments in footnotes of UBC-97 Table 23-II-I-1.

Figures B1 and B2 display the shear wall schedule for the first and second story of the building, respectively. The STHD-type holddowns, which are typically used with this home plan, are replaced with HTT-type holddowns (Simpson Strong-Tie Co. on-line catalog, 2001). The HTT-type holddowns can be installed in the factory. The HTT holddowns are connected to the anchor bolts after the panel installation using threaded rods and coupling nuts. Accurate positioning of the anchor bolts can be achieved by using a template with predrilled holes that will locate the bolt at a required distance from the foundation wall corner. The HTT-type holddowns will also

eliminate interference with sheathing installation (i.e., edge nailing) and exterior finish installation. Note that the STHD holddowns may continue to be used in lieu of the recommended HTT holddowns.

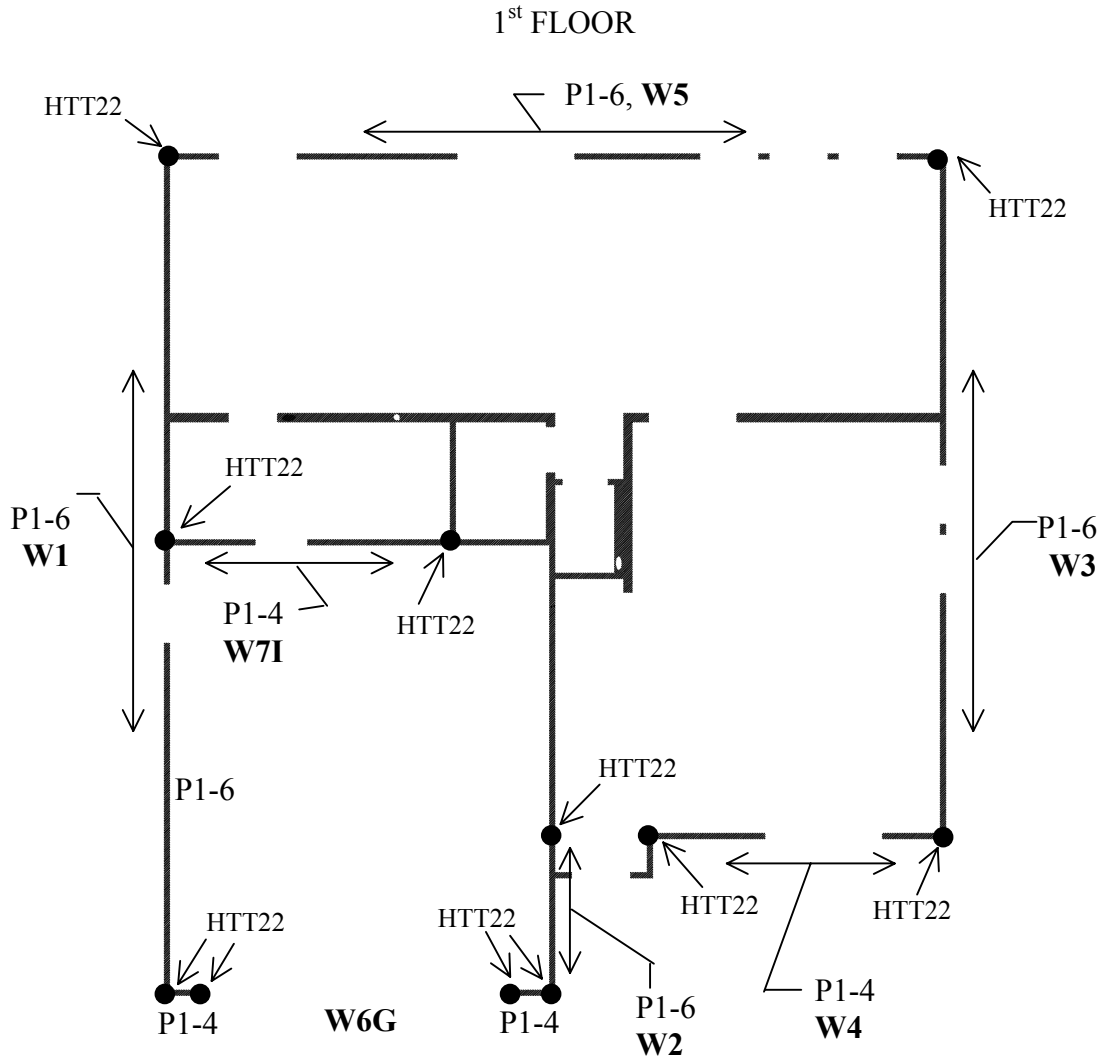

Figure B1
First Floor Shear Wall Schedule
 (Perforated Shear Wall Method, Except Segment Method used at Garage Opening)

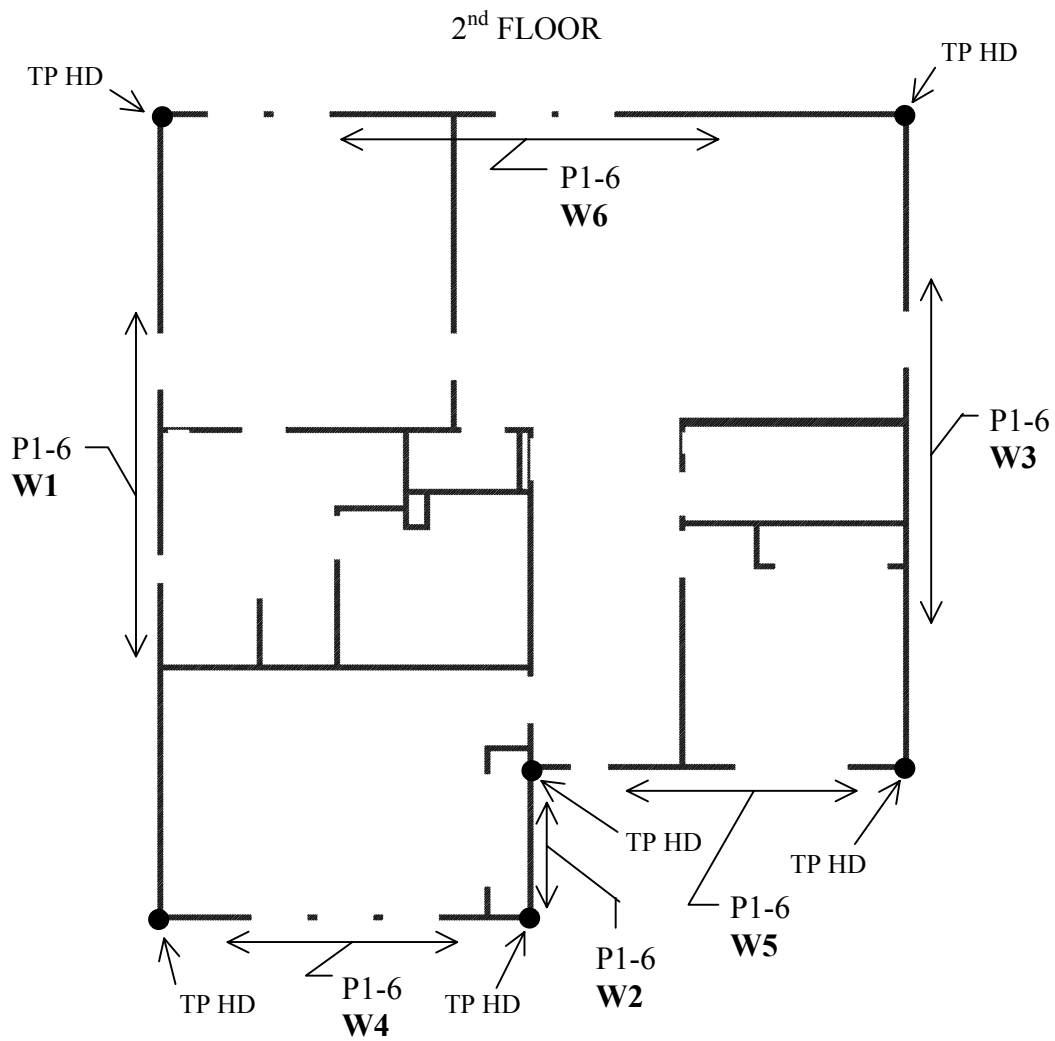

Figure B2
Second Floor Shear Wall Schedule with Truss Plate
Reinforced Holddowns at Corners (TP HD)
(Perforated Shear Wall Method)

Figure B3 shows the anchorage schedule for the front wall according to the perforated shear wall method. In addition, metal truss plates are specified around openings and at the corners.

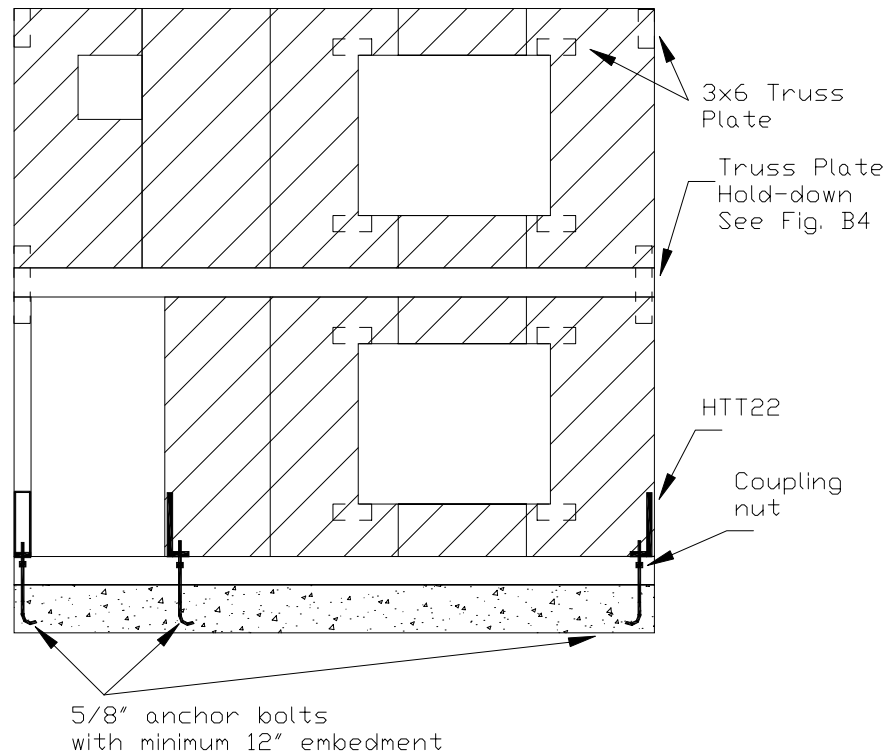

Figure B3
Perforated Shear Wall (Front Wall)

The metal straps on the second story walls are replaced with integral overturning restraints that utilize the combined resistance of metal truss plates, bolts with plate washers, and perpendicular walls. Figure B4 shows construction details of the truss plate holddowns for the second story shear walls. Specifications for the truss plate holddowns follow:

1. 1/2 bolts are located a maximum of 8 inches from the exterior face of the corner, the holes can be drilled in place;
2. 3 x 3 x 0.25-inch square washers are used with the bolts;
3. M II 20 5 x 6 inch MiTek truss plates are installed on both sides of the corner;
4. M II 20 3 x 6 inch MiTek truss plates are installed on both sides of the adjacent corner;
5. sheathing from both wall panels is attached with edge nailing to the same corner (end) stud;
6. the corner studs are pre-cut to accommodate the double bottom plate where 5x6 M II 20 plates are installed; a regular length stud is used with the adjacent wall where 3x6 M II 20 truss plates are used;
7. wall panels are nailed together at corner studs with a minimum of five framing nails (0.131 inch diameter and 3 1/4 inch long);
8. three 12-inch-long spacers are used between the studs of the main corner (corner with 5x6 inch truss plates). The spacers are nailed to each adjacent stud with a minimum of three framing nails (0.131 inch diameter and 3 1/4 inch long) (six nails total per spacer).

Instead, three 4.5-inch nails can be used for full penetration through both studs and the spacer. A full height stud can be used instead of the spacers.

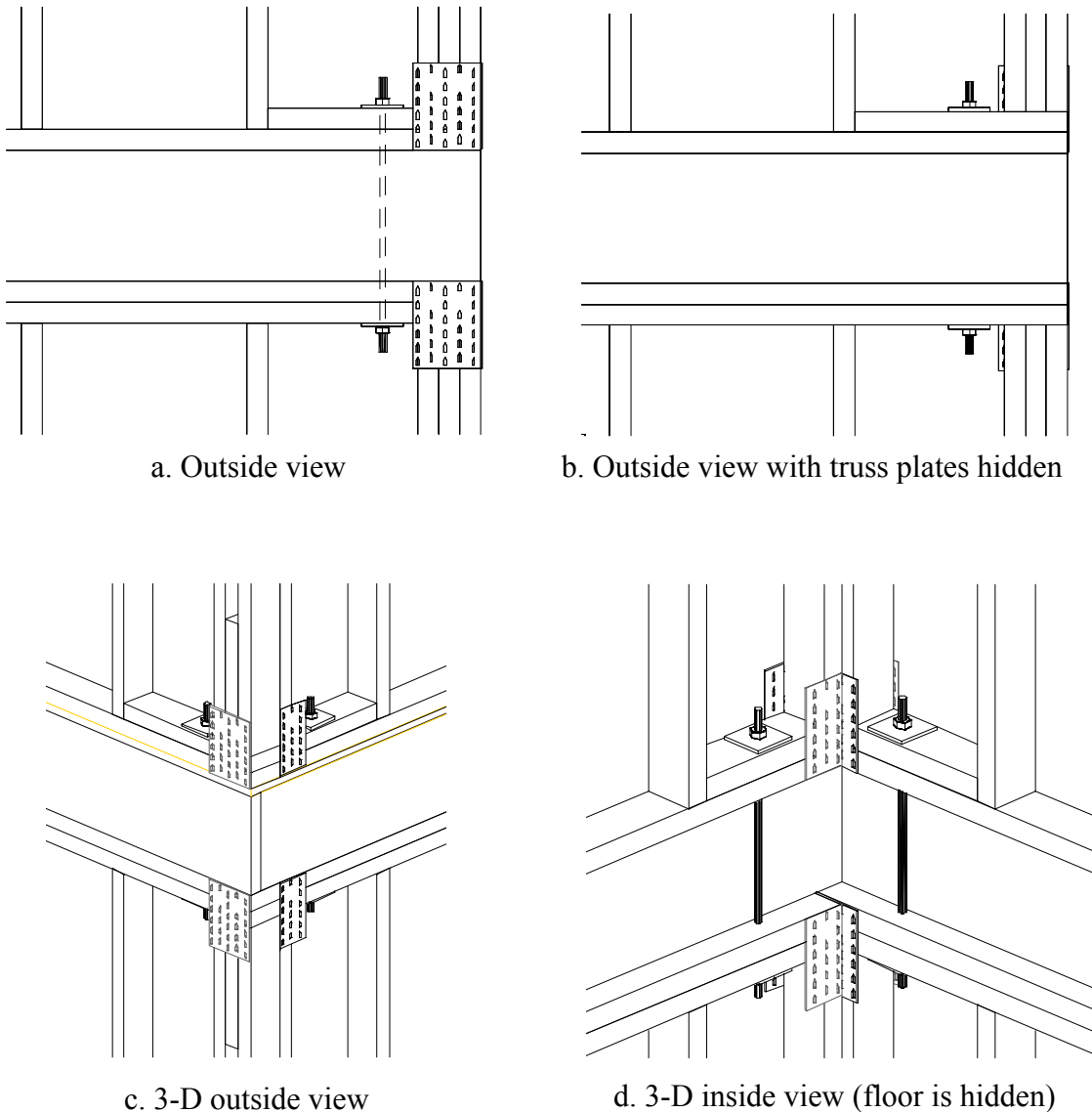

Figure B4
Details of a Truss Plate Holddown for the Second Story Shear Walls
(Sheathing is Not Shown)

This design is based on the following criteria:

1. perforated shear wall method;
2. shear wall panels (as a part of a perforated shear wall) with aspect ratio of 2.5:1 for seismic design (3.5:1 is required by the UBC-97 for the seismic zone 3, Table 23-II-G); and,
3. truss plate overturning restraints on the second story shear walls.

The first item is substantiated with extensive experimental and analytical data on the monotonic and cyclic response of the perforated shear walls. This method is adopted by the Standard Building Code (SBCCI 1999), International Building Code (IBC 2000), and NEHRP Recommended Provisions for Seismic Regulations for New Building and Other Structures (BSSC, 2001).

M II 20 truss plates (3x6) around the windows will provide a mechanism for improved force transfer between the wall segments resulting in a wall configuration that acts more as a unit. Therefore, the second assumption is justified.

The use of the truss plate overturning restraints are substantiated by engineering calculations and results of full-scale testing.

ENGINEERING CALCULATIONS

This section presents engineering calculations that substantiate the proposed shear wall schedule. The structural analysis shows that only the EW walls of the first story are designed to resist loads approaching their allowable design resistance (up to 93 percent). The rest of the walls are considerably oversized and have minimum construction characteristics allowed by the 1997 UBC.

DESIGN METHODS

Horizontal Force Distribution

The analysis uses rigid diaphragm method to distribute lateral forces between the shear walls. This method was confirmed as the most accurate for design of light-frame buildings by recent whole-house testing programs sponsored by HUD, NAHB, and FEMA. Appendix C summarizes some of the technical information that supports the use of the rigid diaphragm method for residential light-frame wood structures.

The direct shear is distributed among the walls relative to their capacities. The torsional moment is defined as the product of the shear force acting on a given story and the eccentricity between the center of rigidity and the center of stiffness for the same story. The moment is distributed among the shear walls according to Equations (B1) and (B2).

$$V_T = \frac{M_T r_i F_i}{J} \quad (B1)$$

$$J = \sum_i^n F_i r_i^2 \quad (B2)$$

where:

V_T = torsional shear load on a wall line;

M_T = torsional moment – a product of total story shear load and perpendicular distance between the load vector resultant resistance vector for load direction under consideration;

r_i = distance from the wall to the center of stiffness (center of resistance);

V_i = design shear wall capacity;

J = torsional moment of inertia of the story.

For seismic design, 5 percent of the building dimension at the level of interest perpendicular to the direction of the force under consideration is added to the building eccentricity (Section 1630.6, 1997 UBC). The torsional shear force is additive to the direct shear. The negative torsional forces that counteract the direct shear are ignored.

Perforated Shear Wall Method

The design shear wall capacity is calculated using perforated shear wall method. The ratio of the shear strength for a wall with openings to the shear strength of a fully sheathed wall, F , is determined as:

$$F = \frac{r}{3 - 2r} \quad (B3)$$

$$r = \frac{1}{1 + \frac{A_o}{H \sum L_i}} \quad (B4)$$

where:

- r = sheathing area ratio;
- A_o = total area of openings;
- H = height of the wall; and,
- $\sum L_i$ = summation of length of all full height wall segments.

LOAD CALCULATIONS

Wind Loads

The 1997 UBC permits the use of ASCE 7, Chapter 6 for calculation of Wind Loads (UBC-97, Chapter 16, Section 1604 – Standards). Therefore, wind loads are determined according to the provisions of ASCE 7-98 *Minimum Design Loads for Buildings and Other Structures* (ASCE 2000). The method for "buildings and other structures" is used (Section 6.5.3, ASCE 7-98).

1. Basic wind speed, V , and wind directionality factor, K_d .

$$V = 85 \text{ mph (Figure 6.1)}$$

$$K_d = 0.85 \text{ main wind force resisting system (Table 6.6)}$$

2. Importance factor, I .

$$I = 1.0 \text{ (Table 6-1)}$$

3. Exposure category and velocity pressure coefficient, K_z or K_h .

Exposure B

The design procedure for buildings and other structures is used (Section 6.5.6.2.1).

$$K_z = 0.61 \text{ (Table 6.5, Case 2, } z = 18'2" \text{)}$$

$$K_h = 0.65 \text{ (Table 6.5, Case 2, } h = 23'7" \text{)}$$

4. Topographic Factor, K_{zt} .

Not included in the design.

5. Gust effect factor, G .

$G = 0.85$ (Section 6.5.8.1 - Rigid Structures)

6. Enclosure classification.

The building is classified as enclosed.

7. Internal pressure coefficient GC_{pi} .

$CP_{pi} = \pm 0.18$ (Table 6-7, enclosed structures)

In case of determining the total shear, the internal pressures cancel out.

8. External pressure coefficients C_p , (Figure 6-3)

Wind in EW direction (perpendicular to ridge)

Walls

$$L/B = 40/43 = 0.93 < 1$$

Windward $C_p = 0.8$

Leeward $C_p = -0.5$

Side walls $C_p = -0.7$

Roof

$$h/L = 23.7 / 40 = 0.6$$

$$\theta = 27^\circ$$

Windward

$$C_p = -0.3 \text{ or } C_p = 0.2$$

Leeward

$$C_p = -0.6$$

Wind in NS direction (parallel to ridge)

Walls

$$L/B = 43/40 = 1.1$$

Windward $C_p = 0.8$

Leeward $C_p = -0.5$

Side walls $C_p = -0.7$

Roof

Cancel out for the total shear

9. Velocity pressure q_h .

$$q_z = 0.00256 K_z K_{zt} K_d V^2 I = 0.00256 (0.61) (1.0) (0.85) (85)^2 (1.0) = 9.6 \text{ lb/ft}^2$$

$$q_h = 0.00256 K_h K_{zt} K_d V^2 I = 0.00256 (0.65) (1.0) (0.85) (85)^2 (1.0) = 10.2 \text{ lb/ft}^2$$

10. Design wind load p.

$$p = q GC_p - q_i (GC_{pi})$$

Wind in EW direction (perpendicular to ridge)

Walls

Windward

$$p = (9.6)(0.85)(0.8) = 6.5 \text{ lb/ft}^2$$

Leeward

$$p = (10.2)(0.85)(-0.5) = -4.3 \text{ lb/ft}^2$$

Side walls

$$p = (10.2)(0.85)(-0.7) = -6.1 \text{ lb/ft}^2$$

Roof

Windward

Negative Pressure

$$p = (10.2)(0.85)(-0.3) = -2.6 \text{ lb/ft}^2$$

Positive Pressure

$$p = (10.2)(0.85)(0.2) = 1.7 \text{ lb/ft}^2$$

Leeward

$$p = (10.2)(0.85)(-0.6) = -5.2 \text{ lb/ft}^2$$

Wind in SN direction (parallel to ridge)

Walls

Windward

$$p = (10.2)(0.85)(0.8) = 6.9 \text{ lb/ft}^2$$

Leeward

$$p = (10.2)(0.85)(-0.5) = -4.3 \text{ lb/ft}^2$$

Side walls

$$p = (10.2)(0.85)(-0.7) = -6.1 \text{ lb/ft}^2$$

Roof

No pressure on the main LFRS

Forces:

Areas are measured from the electronic drawings provided by Quadrant Homes using AutoCAD software package.

EW direction

Roof:

$$F = (1.7 + 5.2) (395 + 51) = 3,077 \text{ lb}$$

Second story

$$F = (6.5 + 4.3) (176) + 3,077 = \mathbf{4,978 \text{ lb}}$$

First story

$$F = (6.5 + 4.3)(392) + 4,978 = \mathbf{9,212 \text{ lb}}$$

NS direction

Roof:

$$F = (6.9 + 4.3) (215) = 2,408 \text{ lb}$$

Second story

$$F = (6.9 + 4.3) (165) + 2,408 = \mathbf{4,256 \text{ lb}}$$

First story

$$F = (6.9 + 4.3)(362) + 4,256 = \mathbf{8,310 \text{ lb}}$$

Seismic Loads

Masses of building components:

Roof:	15 psf
Partitions:	8 psf
Exterior Walls:	10 psf
Diaphragm:	10 psf

Roof mass

It is assumed that the mass per square foot of the garage part of the roof is equal to that of the main part of the building. The roof area includes the 1.5 foot overhang around the building.

$$W_R = [(40 + 3)(35 + 3) + (20 + 3)(8.0)] (15) = \mathbf{27,270 \text{ lb}}$$

Second story wall mass

The mass is computed using half height of the walls and partitions of the story. It is assumed that the partitions are nailed to the ceiling as well as to the floor. The lengths of the partitions are measured from the drawings.

$$W_{W2} = (8.1/2)[(40 + 43)(2)](10) + (8.1/2)[40 + 20 + (16.75)(2) + 12 + 5.5 + (18.2)(2) + 12.25 + 20 + 12](8) = \mathbf{12,933 \text{ lb}}$$

Total mass acting on the second story shear walls

$$W_2 = 27,270 + 12,933 = \mathbf{40,202 \text{ lb}}$$

First story wall mass

The mass is computed using single story wall height and diaphragm depth. It is assumed that the partitions are nailed to the ceiling as well as to the floor.

$$W_{W1} = (8.1 + 1.1)[(40 + 43)(2)](10) + (8.1/2)[40 + 20 + (16.75)(2) + 12 + 5.5 + (18.2)(2) + 12.25 + 20 + 12](8) + (8.1/2)[40 + 20 + 21.75 + (6.75)(3)](8) = \mathbf{24,786 \text{ lb}}$$

Diaphragm mass

$$W_{d1} = [(40)(35) + (20)(8.0)] (10) = \mathbf{15,600 \text{ lb}}$$

Porch roof mass

$$W_{p1} = (9)(9)(15) = \mathbf{1,215 \text{ lb}}$$

Total first story mass

$$W_{s1} = 24,786 + 15,600 + 1,215 = \mathbf{41,600 \text{ lb}}$$

Total mass acting on the first story shear walls

$$W_1 = W_2 + W_{s1} = 40,200 + 41,600 = \mathbf{81,800 \text{ lb}}$$

Static design procedure (Section 1630.2.3 of UBC-97) is used to calculate base shear because it is a two-story standard occupancy structure.

Base shear:

$$V = \frac{2.5 C_a I}{R} W$$

- C_a = 0.36 for Seismic Zone 3 and unknown soil type (Table 16-Q)
- R = 5.5 (Table 16-N)
- I = 1.0 (Table 16-K)

Vertical distribution of force (Section 1630.5, 1997 UBC)

First story shear

$$V_1 = (2.5)(0.36)(81,800)(1.0)/5.5 = 13,385 \text{ lb}$$

Second story shear

$$V_2 = (13,385) (40,202)(19.1)/[(40,202)(19.1) + (41,600)(8.5)] = 9,165 \text{ lb}$$

For allowable stress design, the seismic loads are reduced by a factor of 1.4 (Section 1612.3.1, 1997 UBC).

$$V_1 = 13,385/1.4 = \mathbf{9,561 \text{ lb}}$$

$$V_2 = 9,165/1.4 = \mathbf{6,546 \text{ lb}}$$

Shear Wall Design

The allowable shear values are determined from Table 23-II-I-1 of the UBC-97. The values are reduced with the species adjustment factor of 0.82 to account for the specific gravity of the framing members made of Hem-Fir lumber (SG = 0.43).

Assumptions:

Shear walls	Perforated shear wall method, holddowns only at the corners, truss plates are used around openings and at the corners for enhanced performance. The maximum allowable shear wall aspect ratio of 2.5:1 is used for segments within a perforated shear wall for both wind and seismic design.
Garage door	segmented shear wall with 4 inch on center nailing schedule (352 lb/ft of braced wall panels)
Species	Hem-Fir
Sheathing	7/16 OSB
Nailing schedule	6/12 inch (229 lb/ft), all EW walls of the first floor 4/12 (352 lb/ft) except the north wall (Wall 5)
Sheathing Nails	8d common or equivalent pneumatic (D=0.131 inch)
Stud spacing	16 inches on center

Results of Wind Design:

Second Floor - NS

Wall	Direct Shear Force, lb	Torsional Moment, lb-ft	Torsional Shear Force, lb	Total Shear Force, lb	Wall Capacity, lb	Check
		6,261				
W1 ¹	2,051		-102	2,051	8,080	Ok
W2	466		2	468	1,837	Ok
W3	1,738		101	1,839	6,847	Ok
W4			-29	29	1,610	Ok
W5			-28	28	2,241	Ok
W6			56	56	4,855	Ok
Total	4,256					

¹See Figure B2 for wall notations.

Second Floor - EW

Wall	Direct shear Force, lb	Torsional Moment, lb-ft	Torsional shear force, lb	Total shear force, lb	Wall Capacity, lb	Check
		-16,903				
W1			277	277	8,080	Ok
W2			-5	5	1,837	Ok
W3			-272	272	6,847	Ok
W4	921		77	998	1,610	Ok
W5	1,281		75	1,356	2,241	Ok
W6	2,776		-152	2,776	4,855	Ok
Total	4,978					

First Floor - NS

Wall	Direct shear Force, lb	Torsional Moment, lb-ft	Torsional shear force, lb	Total shear force, lb	Wall Capacity, lb	Check
		28,862				
W1 ¹	4,503		-504	4,503	8,314	Ok
W2	746		18	764	1,378	Ok
W3	3,060		487	3,547	5,650	Ok
W4			-127	127	2,367	Ok
W5			231	231	3,087	Ok
W6G			-110	110	1,322	Ok
W7I			6	6	4,838	Ok
Total	8,310					

¹See Figure B1 for wall notations.

First Floor - EW

Wall	Direct shear Force, lb	Torsional Moment, lb-ft	Torsional shear force, lb	Total shear force, lb	Wall Capacity, lb	Check
		-4,106				
W1			72	72	8,314	Ok
W2			-2	2	1,378	Ok
W3			-69	69	5,650	Ok
W4	1,877		18	1,895	2,367	Ok
W5	2,448		-33	2,448	3,087	Ok
W6G	1,049		16	1,064	1,322	Ok
W7I	3,838		-1	3,838	4,838	Ok
Total	9,212					

Results of Seismic Design:

Second Floor - NS

Wall	Direct Shear Force, lb	Torsional Moment, lb-ft	Torsional Shear Force, lb	Total Shear Force, lb	Wall Capacity, lb	Check
		16,008				
W1 ¹	3,155		-262	3,155	8,080	Ok
W2	717		5	722	1,837	Ok
W3	2,674		257	2,931	6,847	Ok
W4			-73	73	1,610	Ok
W5			-71	71	2,241	Ok
W6			144	144	4,855	Ok
Total	6,546					

¹See Figure B2 for wall notations.

Second Floor - EW

Wall	Direct shear Force, lb	Torsional Moment, lb-ft	Torsional shear force, lb	Total shear force, lb	Wall Capacity, lb	Check
		-32,037				
W1			524	524	8,080	Ok
W2			-9	9	1,837	Ok
W3			-515	515	6,847	Ok
W4	1,211		147	1,357	1,610	Ok
W5	1,685		141	1,826	2,241	Ok
W6	3,651		-288	3,651	4,855	Ok
Total	6,546					

First Floor - NS

Wall	Direct shear Force, lb	Torsional Moment, lb-ft	Torsional shear force, lb	Total shear force, lb	Wall Capacity, lb	Check
		44,992				
W1 ¹	5,181		-786	5,181	8,314	Ok
W2	859		27	886	1,378	Ok
W3	3,521		759	4,280	5,650	Ok
W4			-198	198	2,367	Ok
W5			359	359	3,087	Ok
W6G			-171	171	1,322	Ok
W7I			10	10	4,838	Ok
Total	9,561					

¹See Figure B1 for wall notations.

First Floor - EW

Wall	Direct shear Force, lb	Torsional Moment, lb-ft	Torsional shear force, lb	Total shear force, lb	Wall Capacity, lb	Check
		-22,807				
W1			398	398	8,314	Ok
W2			-14	14	1,378	Ok
W3			-385	385	5,650	Ok
W4	1,948		100	2,049	2,367	Ok
W5	2,541		-182	2,541	3,087	Ok
W6G	1,088		87	1,175	1,322	Ok
W7I	3,983		-5	3,983	4,838	Ok
Total	9,561					

DESIGN OF OVERTURNING RESTRAINTS

Design of Truss Plate Holddowns (Figure B4) for the Second Story Shear Walls

The design of overturning restraints is governed by the seismic analysis. The uplift forces are calculated based on the capacity of the wall that can be achieved during a seismic event rather than on the reduced forces calculated using the R-factor. This design procedure is consistent with the seismic design philosophy incorporated in the procedures for determination of the structural seismic loads. This approach results in a more accurate connection design.

According to the *NEHRP Guidelines for the Seismic Rehabilitation of Buildings* (FEMA-273) (BSSC, 1997), capacity of the shear walls specified for the second floor is $v = 720$ lb/ft

Including adjustment for specific gravity of Hem-Fir lumber (SG=0.43):

$$v = (720)(1 - (0.5 - \text{SG})) = (720)(1 - (0.5 - 0.43)) = 670 \text{ lb}$$

Uplift force (based on the actual capacity of the shear wall):

$$T = v h = (670)(8) = 5,360 \text{ lb}$$

where:

v = unit shear capacity;

h = shear wall height.

The uplift capacity of the truss plate holddowns (Figure 4):

$$U1 = (145 \text{ psi})[(15 \text{ in}^2)](0.85)(3.2) = 5,916 \text{ lb}$$

where:

145 psi = allowable lateral resistance value for M II 20 MiTech Truss Connector Plates installed in Hem-Fir lumber (ICBO Evaluation Report ER-4922, ICBO 1999) for the EE Plate Orientation;

15 in² = area of the double bottom plate covered by the truss plate;

0.85 = reduction coefficient due to truss plate installation on the narrow face of the member (Section 2.3.4, ER-4922);

3.2 = reduction coefficient that adjusts the average test value to the design value (Section 7.1.9, ANSI/TPI 1-1995, TPI 1995).

This approach for determining the resistance of a truss plate hold-down was validated with full scale testing as reported in *Case Study II – Light-Frame Wood Panels* of this publication. In summary, the testing of a shear wall showed that this type of a holddown with a 12.75 inch contact area and assembled with SPF lumber resisted an uplift force of 5,377 lb.

The uplift capacity of the adjacent corner:

$$U2 = (145 \text{ psi})[(4.5 \text{ in}^2)](0.85)(3.2) = 1,775 \text{ lb}$$

where:

4.5 in^2 = area of the double bottom plate covered by the truss plate;

Capacity of the truss plate holddown including the corner resistance:

$$UT = U1 + U2 = 5,916 + 1,775 = 7,691 \text{ lb}$$

Holddown overstrength factor = Uplift Resistance/Uplift Force = $7,691/5,360 = 1.44 > 1.0$ - OK

The holddown overstrength factor should be interpreted as a factor that if greater than unity indicates that the sheathing nails will reach their capacity before the holddown reaches its capacity. Thus, a ductile shear wall response is ensured for a holddown overstrength factor of greater than unity. It should be noted that the uplift force is not reduced by any portion of the roof dead load and the second story dead load. Therefore, the overstrength factor of 1.44 can be considered as a conservative estimate.

Design of Overturning Holddowns for the First Story Shear Walls

According to the *NEHRP Guidelines for the Seismic Rehabilitation of Buildings* (FEMA-273) (BSSC, 1997), capacity of the shear walls specified for the first floor:

$$v = 900 \text{ lb/ft}$$

Including adjustment for specific gravity of Hem-Fir lumber (SG=0.43):

$$v = (900)(1 - (0.5 - \text{SG})) = (900)(1 - (0.5 - 0.43)) = 837 \text{ lb}$$

Uplift force:

$$T = v h = (837)(8) = 6,696 \text{ lb}$$

Total uplift force including the second story:

$$T = 6,696 + 5,360 = 12,056 \text{ lb}$$

The uplift capacity of HTT22 is 13,150 lb (Simpson Strong-Tie Co. on-line catalog, 2001)

Holddown overstrength factor = $13,150/12,056 = 1.1$ - OK

Note that the uplift force is not reduced by any portion of the dead load of the second story. Thus, the lower story uplift for anchorage design may be considered to be conservative and the actual overstrength factor is greater than 1.1.

APPENDIX C RIGID DIAPHRAGM METHOD

Due to a complex three-dimensional force distribution mechanism involved in the analysis of the stiffness characteristics of the diaphragm–shear wall assemblies, there is a lack of guidelines on the selection of the appropriate lateral force distribution procedures in the model building codes. As a typical practice, the current building codes provide stringent rules in favor of more conservative flexible diaphragm method. Recently, several studies have been conducted towards answering the problem of the lateral force distribution between the shear walls in light-frame buildings. A summary of these studies follows.

[1] This study investigated load sharing mechanism between shear walls in a 16 foot by 32 foot one-story light-frame house. The roof diaphragm was sheathed with plywood panels using eight-penny nails. The sheathing was not glued or blocked. Gypsum panels were used on the ceiling. Results of the testing showed that the roof diaphragm exhibited nearly rigid behavior. The load distribution between the shear walls depended on both wall stiffness and wall position within the building. The walls perpendicular to the direction of loading resisted between 8 and 25 percent of the total load due to diaphragm rotation.

[2] The researchers presented a three-dimensional finite element model of a light-frame wood house. The model was validated using results from a full-scale testing program. The model was used to evaluate the accuracy of the rigid and flexible diaphragm design methods using a 16 foot by 32 foot light-frame wood buildings with two partition walls. Results of the modeling showed that the flexible diaphragm method misrepresented the shear wall forces with an error exceeding 120 percent, whereas the rigid diaphragm method predicted the shear wall forces with a maximum error of 21 percent. Both methods provided results that overestimated and underestimated the finite element model predictions. The load sharing mechanism modeled by the rigid diaphragm method was representative of the experimental and finite element modeling results, whereas the flexible diaphragm method provided an arbitrary force distribution based on building geometry (i.e. tributary areas) rather than stiffness.

[3] NEHRP Seismic Design Provisions incorporate the state-of-the-art design methods for analysis of structures against seismic forces. The Provisions follow the methodology previously introduced in the UBC to define rigid and flexible diaphragm buildings. However, for light-frame structures, the Provisions require using the rigid diaphragm approach if the diaphragm is assembled with structural panel sheathing (Section 5.2.3.1). This indicates that the Provisions encourage using the rigid diaphragm method as opposed to the flexible diaphragm method for design of light-frame buildings.

[4] NEHRP Commentary on the Guidelines for the Seismic Rehabilitation of Buildings provides recommendations for seismic analysis of existing structures. In Chapter 8, which discusses wood construction, the Commentary indicates that recent studies demonstrated rigid behavior of the diaphragms in wood buildings. Therefore, the lateral loads should be distributed to the shear walls based on the relative stiffness instead of tributary areas.

[5] This project investigated the applicability of various design methods for distribution of the lateral forces between the shear walls in a light-frame building. The analytical results were

validated using experimental data from testing of a full-scale L-shaped one-story wood-frame 30 foot by 36 foot house. Results of the project indicated that the rigid diaphragm method accurately predicted force distribution between the shear walls with a maximum error of 11 percent, whereas the error of the flexible diaphragm method exceeded 37 percent. This building had a conventional roof diaphragm assembled without gluing or blocking the sheathing.

[6] One of the objectives of this project was to evaluate the relative stiffness of the diaphragm–shear wall system of a 16 foot by 20 foot house. Eight diaphragm configurations were investigated each with different combination of nailing schedule, adhesive, and blocking. Diaphragms assembled with nails and without adhesive or blocking were classified as flexible according to the UBC-97 provisions, whereas diaphragms assembled with either adhesive or blocking or both were classified as rigid. This testing program used shear walls without perforations and a building configuration without intermediate shear walls. Both of these building attributes contributed towards the selection of the flexible diaphragm approach. Therefore, results of this testing program conservatively represent the actual response of light-frame homes that typically have many openings. It should be noted that the definition of the rigid diaphragm provided in the UBC does not necessarily mean that buildings that fall beyond the scope of the rigid diaphragm definition will actually behave as flexible diaphragm buildings.

References:

- [1] Phillips, T. L., Itani, R. Y., and McLean, D. I. 1992. Lateral Load Sharing by Diaphragms in Wood-Framed Buildings. *Journal of Structural Engineering*, Vol. 119(5), pp. 1556-1571.
- [2] Kasal, B., and Leichti, R. J. 1992. Incorporating Load Sharing in Shear Wall Design of Light-Frame Structures. *Journal of Structural Engineering*, Vol. 118, No. 12, pp. 3350-3361.
- [3] Building Seismic Safety Council. 1997. NEHRP Recommended Provisions for Seismic Regulations for New Buildings and Other Structures (FEMA Publication 302). Washington, DC.
- [4] Building Seismic Safety Council. 1997. NEHRP Commentary on the Guidelines for the Seismic Rehabilitation of Buildings (FEMA Publication 274). Washington, DC.
- [5] Foliente, G., Paevere, P., Kasal, B., and Collins, M. 2000. Whole Structure Testing and Analysis of a Light-Frame Wood Building. Phase 2 – Design Procedures Against Lateral Loads. BCE DOC 00/177. CSIRO, Australia.
- [6] Fisher, D., Filiatrault, A., Folz, B., Uang, C., and Seible, F. 2000. Shake Table Tests of a Two-Story Woodframe House. Report No. SSRP – 2000/15. Division of Structural Engineering, University of California, San Diego.

APPENDIX D METRIC CONVERSION FACTORS

The following list provides the conversion relationship between U.S. customary units and the International System (SI) units. A complete guide to the SI system and its use can be found in ASTM E 380, Metric Practice.

To convert from	to	multiply by
-----------------	----	-------------

Length

inch (in.)	micron (μ)	25,400
inch (in.)	centimeter	2.54
inch (in.)	meter (m)	0.0254
foot (ft)	meter (m)	0.3048
yard (yd)	meter (m)	0.9144
mile (mi)	kilometer (km)	1.6

Area

square foot (sq ft)	square meter (sq m)	0.09290304
square inch (sq in)	square centimeter (sq cm)	6.452
square inch (sq in.)	square meter (sq m)	0.00064516
square yard (sq yd)	square meter (sq m)	0.8391274
square mile (sq mi)	square kilometer (sq km)	2.6

Volume

cubic inch (cu in.)	cubic centimeter (cu cm)	16.387064
cubic inch (cu in.)	cubic meter (cu m)	0.00001639
cubic foot (cu ft)	cubic meter (cu m)	0.02831685
cubic yard (cu yd)	cubic meter (cu m)	0.7645549
gallon (gal) Can. liquid	liter	4.546
gallon (gal) Can. liquid	cubic meter (cu m)	0.004546
gallon (gal) U.S. liquid*	liter	3.7854118
gallon (gal) U.S. liquid	cubic meter (cu m)	0.00378541
fluid ounce (fl oz)	milliliters (ml)	29.57353
fluid ounce (fl oz)	cubic meter (cu m)	0.00002957

Force

kip (1000 lb)	kilogram (kg)	453.6
kip (1000 lb)	Newton (N)	4,448.222
pound (lb)	kilogram (kg)	0.4535924
pound (lb)	Newton (N)	4.448222

Stress or pressure

kip/sq inch (ksi)	megapascal (Mpa)	6.894757
kip/sq inch (ksi)	kilogram/square centimeter (kg/sq cm)	70.31
pound/sq inch (psi)	kilogram/square centimeter (kg/sq cm)	0.07031
pound/sq inch (psi)	pascal (Pa) **	6,894.757
pound/sq inch (psi)	megapascal (Mpa)	0.00689476
pound/sq foot (psf)	kilogram/square meter (kg/sq m)	4.8824
pound/sq foot (psf)	pascal (Pa)	47.88

To convert from	to	multiply by
-----------------	----	-------------

Mass (weight)

pound (lb) avoirdupois	kilogram (kg)	0.4535924
ton, 2000 lb	kilogram (kg)	907.1848
grain	kilogram (kg)	0.0000648

Mass (weight) per length

kip per linear foot (klf)	kilogram per meter (kg/m)	0.001488
pound per linear foot (plf)	kilogram per meter (kg/m)	1.488

Moment

1 foot-pound (ft-lb)	Newton-meter (N-m)	1.356
----------------------	--------------------	-------

Mass per volume (density)

pound per cubic foot (pcf)	kilogram per cubic meter (kg/cu m)	16.01846
pound per cubic yard (lb/cu yd)	kilogram per cubic meter (kg/cu m)	0.5933

Velocity

mile per hour (mph)	kilometer per hour (km/hr)	1.60934
mile per hour (mph)	kilometer per second (km/sec)	0.0268

Temperature

degree Fahrenheit ($^{\circ}$ F)	degree Celsius ($^{\circ}$ C)	$t_C = (t_F - 32)/1.8$
degree Fahrenheit ($^{\circ}$ F)	degree Kelvin ($^{\circ}$ K)	$t_K = (t_F + 459.7)/1.8$
degree Kelvin ($^{\circ}$ F)	degree Celsius ($^{\circ}$ C)	$t_C = (t_K - 32)/1.8$

*One U.S. gallon equals 0.8327 Canadian gallon

**A pascal equals 1000 Newton per square meter.

The prefixes and symbols below are commonly used to form names and symbols of the decimal multiples and submultiples of the SI units.

Multiplication Factor	Prefix	Symbol
1,000,000,000 = 10^9	giga	G
1,000,000 = 10^6	mega	M
1,000 = 10^3	kilo	k
0.01 = 10^{-2}	centi	c
0.001 = 10^{-3}	milli	m
0.000001 = 10^{-6}	micro	μ
0.000000001 = 10^{-9}	nano	n

U.S. Department of Housing and Urban Development
HUD USER
P.O. Box 23268
Washington, DC 20026-3268

FIRST CLASS MAIL
POSTAGE & FEES PAID
HUD
PERMIT NO. G-795

Official Business
Penalty for Private Use \$300

Return Service Requested

July 2002

