

A Builder's Guide to



***Marketable
Affordable
Durable
Entry-Level Homes
To Last***



DISCLAIMER

The U.S. government does not endorse products or manufacturers. Trade or manufacturers' names appear herein solely because they are considered essential to the subject of this report.

The contents of this report are the views of the contractor and do not necessarily reflect the views or policy of the U.S. Department of Housing and Urban Development or the U.S. government.

ACKNOWLEDGMENTS

Principal Authors: Chad Garner, Mark Nowak, and Peter Yost

Document Development: Anne Holtz

Graphic Design: Jane Willeboordse

This manual would not have been possible without the hard work of the steering committee and the contributions of many affordable home builders. The NAHB Research Center would like to recognize the commitment of the following individuals and associations:

Steering Committee Members

Nelson Carbonell, U.S. Department of Housing and Urban Development
Morton Frank, Affordable Housing Committee of American
Rose Geier Grant, State Farm Insurance Companies
Ben Harwell, Home Buyers Warranty Corporation
Jane Katz, Fannie Mae
Randy Luther, Centex Homes
Aaron Miripol, Southwest Visions, Inc.
Anne O'Reilly, *Professional Builder*
Bob Schmitt, Bob Schmitt Homes
Rick Schwolsky, *Builder*
Howard Ways, The Enterprise Foundation

Contributing Builders

Mel Aho, Aho Construction
John Barcelona, The Woodhill Corporation
Perry Bigelow, The Bigelow Group
Milton Bloom, Southern General Builders
Bill Eich, Eich Construction
Hap Hildebrand, Eid-Co
Lee Holztrager, Sawbuck, Inc.
Joseph E. Link, Market Wise
Duane Marlink, Marlink Builders
Jim Meigs, The Bigelow Group
Dan Mustari, Whitehall Homes, Inc.
Dave Oyler, Melody Homes
Eddie Phillips, Phillips Builders
Rick Scranton, Best Homes
Mike Suhaldonik, Construx of Illinois
Krish Naraine, Northern Enterprise Home Manufacturing

Contributing Associations

Greater Atlanta Home Builders Association
Greater Grand Rapids Home Builders Association

Foreword

In 1995, President Clinton established a national goal of eight million new homeowners by the end year 2000. We are now well on the way to meeting this goal. However, more can be done. Many homebuilders find it ever more difficult to produce well-built affordable housing. Increasing costs for land, development and materials combined with higher homebuyer expectations have increased new home prices beyond what many first-time buyers can afford.

In the face of this, some builders have begun utilizing new technologies and practices to recapture this market. This manual seeks to provide builders with a source of information on many of the technologies and practices—some old and some new—that these builders are successfully using to provide **Marketable Affordable Durable Entry-level (MADE)** homes for first time homebuyers. Included are practical plans, designs, and techniques that can be used now by homebuilders, nonprofits, and others to build housing that is of high quality, energy efficient, and durable while also increasing affordability.

This manual is part of a major new initiative recently announced by the President in May, 1998—the Partnership for Advancing Technology in Housing (PATH). PATH is a private/public partnership between industry and government to speed the creation and wide-spread use of advanced technologies to radically improve the quality, durability, environmental performance, energy efficiency and affordability of our Nation's homes. The PATH initiative seeks to bring manufacturers, designers, builders, and professionals throughout the building industry together in a partnership aimed at:

- Decreasing the cost of homeownership,
- Increasing energy efficiency of homes,
- Decreasing the environmental impact of homebuilding, and
- Increasing home durability.

We hope that these techniques and designs will now become widely adopted throughout the homebuilding industry. It is through the use of such innovation and creativity that the dream of homeownership can be made available to all American families.

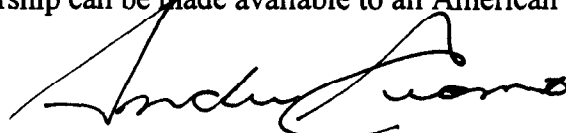

Andrew Cuomo, Secretary
U.S. Department of Housing and
Urban Development

CONTENTS

INTRODUCTION.....	1
MADE-to-Last Home Building.....	4
1. Marketable Homes.....	4
2. Affordable Construction.....	4
3. Durability for Long-Lasting Homes.....	5
4. The MADE-to-last Demonstration Home.....	5
MARKETING THE MADE-TO-LAST HOME.....	7
Major Principles.....	7
Cost Control.....	7
Expandability.....	7
Flexibility.....	8
Curb Appeal.....	8
Expectation Management.....	8
Financing.....	8
Expandability.....	9
Unfinished Interior Space: The Attic.....	9
Unfinished Interior Space: The Basement.....	10
Exterior Space: Garages and Carports.....	11
Future Additions.....	12
HVAC, Plumbing, and Electrical Considerations.....	13
Flexibility.....	14
Open Floor Plan.....	14
Combined Use of Space.....	14
Room Conversions.....	15
Accessible Design.....	15
Curb Appeal.....	16
Entry/Porch.....	16
Variations To Roof Line For An Affordable House.....	16
Window And Door Placement.....	17
Landscaping.....	17
Expectation Management.....	18
Financing.....	19
USEFUL REFERENCES.....	22
AFFORDABLE CONSTRUCTION.....	23
Lot Size/Placement Of Home.....	26
Manufactured Housing.....	27
Room Layouts.....	29
Kitchens And Baths.....	29
Kitchens.....	29
Baths.....	29
Doors and Windows.....	30
Foundations.....	31
Framing.....	34
Finishes And Miscellaneous.....	37
Purchasing.....	39
USEFUL REFERENCES.....	40

DURABILITY FOR LONG LASTING AFFORDABLE HOMES.....41

The Builder’s Role.....42

Issue: Poor Drainage.....42

Issue: Foundation Wall Cracks and Water Leakage.....44

Issue: Soil Swelling or Settlement.....45

Issue: Concrete Slab Cracking.....46

Issue: Warped or Delaminated Sheathing, Doors, and Other Products.....47

Issue: Roof, Window, and Other Water Leaks.....48

Issue: Noisy Floors.....49

Issue: Inoperable Windows or Doors.....50

Issue: Drywall Finish.....50

Issue: Buckled Siding.....51

Issue: Termites.....52

Issue: Structural Damage From Wind and Earthquakes.....52

Issue: Energy Efficiency/Indoor Moisture.....54

Helping the Homeowner.....56

General Recommendations for the Homeowner’s Manual.....57

USEFUL REFERENCES.....60

PUTTING IT ALL TOGETHER: THE MADE-TO-LAST DEMONSTRATION HOME.....61

APPENDIX A: EXAMPLE OF BUILDER INNOVATIVE FINANCING.....A-1

APPENDIX B: KEY CONCEPTS FOR STREAMLINING LAND DEVELOPMENT.....B-1

APPENDIX C: SPECIFIC RECOMMENDATIONS FOR THE HOMEOWNER’S MANUAL.....C-1

FIGURES

FIGURE 1 - COST CONTROL	7
FIGURE 2 - ATTIC SPACE DESIGN	9
FIGURE 3 - ATTIC TRUSS	9
FIGURE 4 - BASEMENT CONVERSION	10
FIGURE 5 - FINISHED GARAGE	11
FIGURE 6 - FINISHED GARAGE FLOOR ASSEMBLY	11
FIGURE 7 - REAR GABLE ADDITION	12
FIGURE 8 - FUTURE BATHROOM STACKED OVER EXISTING BATH	13
FIGURE 9 - OPEN FLOOR PLANS	14
FIGURE 10 - COMBINED USE OF SPACE	14
FIGURE 11 - ROOM CONVERSION	15
FIGURE 12 - LOFT SPACE	15
FIGURE 13 - ATTRACTIVE FRONT ELEVATIONS WITH PORCHES	16
FIGURE 14 - SIMPLE VARIATIONS ON ROOF LINES	16
FIGURE 15 - EFFECTIVE WINDOW PLACEMENT	17
FIGURE 16 - SIMPLE STRATEGIC LANDSCAPING	17
FIGURE 17 - MARKET CREEP	18
FIGURE 18 - HELPFUL FINANCING CONTACTS	21
FIGURE 19 - GREATER GRAND RAPIDS HOME BUILDERS ASSOCIATION COST BREAKDOWN	23
FIGURE 19 (CONT.)	24
FIGURE 20 - MANUFACTURED HOUSING GROWTH	24
FIGURE 21 - ALTERNATIVE LOT LAYOUTS	27
FIGURE 22 - WALK-IN PANTRY	29
FIGURE 23 - OPEN KITCHEN SHELVING	29
FIGURE 24 - STEMWALL FOUNDATION	31
FIGURE 25 - TYPICAL FPSF	32
FIGURE 26 - PRECAST FOUNDATION	33
FIGURE 27 - FLOOR TRUSSES AND I-JOISTS	34
FIGURE 28 - EXTERIOR DETAILS	37
FIGURE 29 - BELOW-GRADE DRAINAGE DETAILS	43
FIGURE 30 - ABOVE-GRADE DRAINAGE DETAILS	45
FIGURE 31 - SLAB DETAILS	46
FIGURE 32 - OVERHANG AND WINDOW CAP FLASHING DETAIL	48
FIGURE 33 - COMMON CAUSE OF FLOOR SQUEAKS	49
FIGURE 34 - WINDOW SHIMMING DETAIL	50
FIGURE 35 - WINDOW CORNER FLASHING DETAIL	50
FIGURE 36 - DRYWALL CLIPS WITH TWO-CORNER STUDS AND FLOATING CEILING/INTERIOR PARTITION JOINTS	51
FIGURE 37 - TERMITE CONTROL	52
FIGURE 38 - EXAMPLES OF HURRICANE DAMAGE	53
FIGURE 39 - DUCT LEAKAGE	54
FIGURE 40 - LEADING CAUSES OF AIR LEAKAGE	55

The logo features the word "MADE" in a large, bold, black sans-serif font. Below it, the words "to Last" are written in a smaller, bold, black sans-serif font. The text is centered within a white rectangular area that has a background of horizontal lines. The lines are more densely packed on the left side and become more sparse towards the right, creating a sense of depth or a shadow effect.

MADE

to Last

INTRODUCTION

It's becoming harder and harder for builders to produce and sell those well-built, well-priced, starter homes of the past. Many builders indicate that they are producing the homes that buyers want, but a study by NAHB entitled *What Home Buyers Want* points to a large gap between first-time buyers' expectations and what they can actually afford. Furthermore, new home price information supports that the market in many areas is moving away from entry-level homes and more toward the move-up buyer. Despite this latest trend, research also shows that markets exist for affordable homes and that manufactured housing is capturing a growing portion of this market that has historically been the domain of the site-built home. According to a report recently completed by the NAHB Research Center, manufactured housing sales increased by 72 percent between 1992 and 1995 and currently make up over 30 percent of all single-family homes sold. During the same period, site-built housing starts have increased by approximately 17 percent.

There are, however, builders in various markets who are successfully building and selling affordable site-built homes. Their experiences represent a valuable resource of successful practices that other builders can learn from and apply in their own markets. The U.S. Department of Housing and Urban Development and the NAHB Research Center, with the help of nationally renowned experts and affordable home builders, has prepared this manual for building **Marketable, Affordable, and Durable Entry-level homes (MADE)**. The MADE manual will provide builders with:

- *Tools necessary to market affordable housing to the entry-level buyer;*
- *Successful techniques for building affordable, durable housing;*
- *Methods to define home buyers expectations and fulfill their needs both before and after the sale; and*
- *Preliminary plans illustrating how many of these techniques fit into a MADE-to-Last demonstration home.*

The key features of the demonstration home are identified on the following pages. The prototype demonstration home will provide builders with a real example of how to incorporate the ideas of this manual into their homes. These plans will be used to build a MADE-to-Last Demonstration Home in the NAHB National Research Home Park, located in Upper Marlboro, Maryland.

MADE Demonstration Home Summary of Concepts

1 Expandability/ Flexibility	2 Curb Appeal/ Marketability	3 Affordability	4 Durability
1a <i>Stairs for Future Attic Expansion</i>	2a <i>Front Porch/Entry</i>	3a <i>Modular Dimensions</i>	4a <i>Front Porch (Shading)</i>
1b <i>Steep Sloped Roof</i>	2b <i>Variations in Roof Line</i>	3b <i>Modest Square Footage</i>	4b <i>Grade Sloped Away From Foundation</i>
1c <i>Flexible/Open Living Area</i>	2c <i>Landscaping</i>	3c <i>Kitchen Pantry</i>	4c <i>Roof Overhangs</i>
1d <i>Expandable Areas</i>		3d <i>Lot Reconfiguration</i>	4d <i>Gutters and Downspouts/ Sheltered Entryway</i>
1e <i>Easy Access/ Wider Doorways</i>		3e <i>Strategic Window Placement</i>	
		3f <i>OVE Framing Techniques</i>	
		3g <i>Stacked Bathrooms</i>	

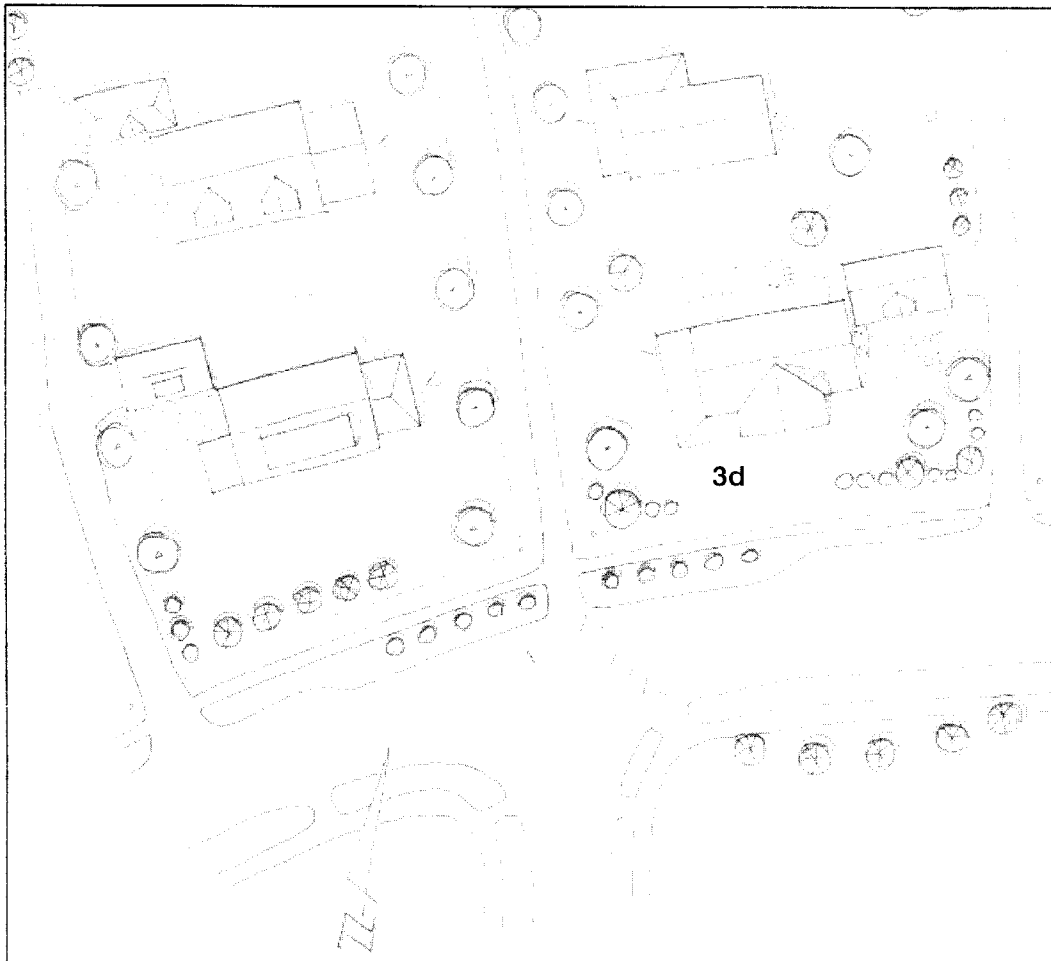

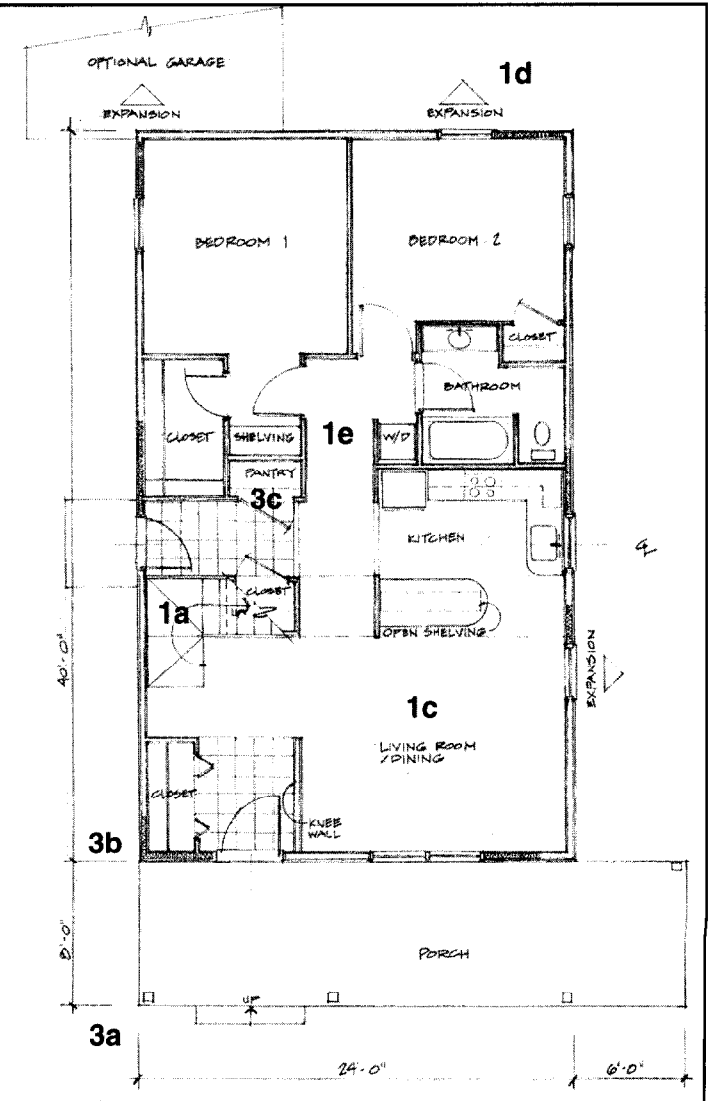
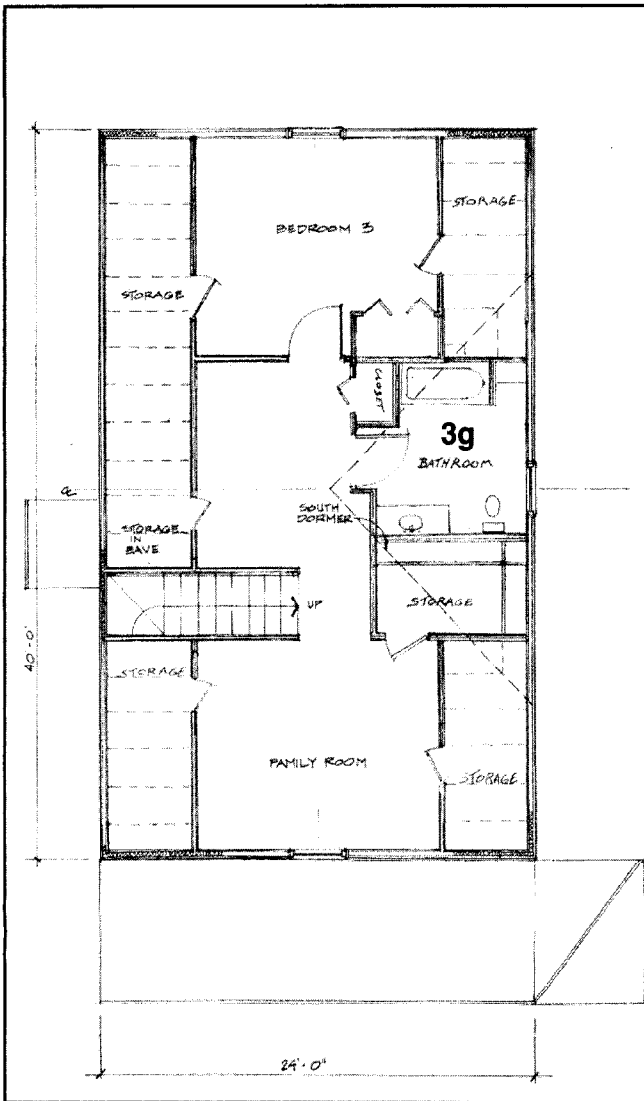
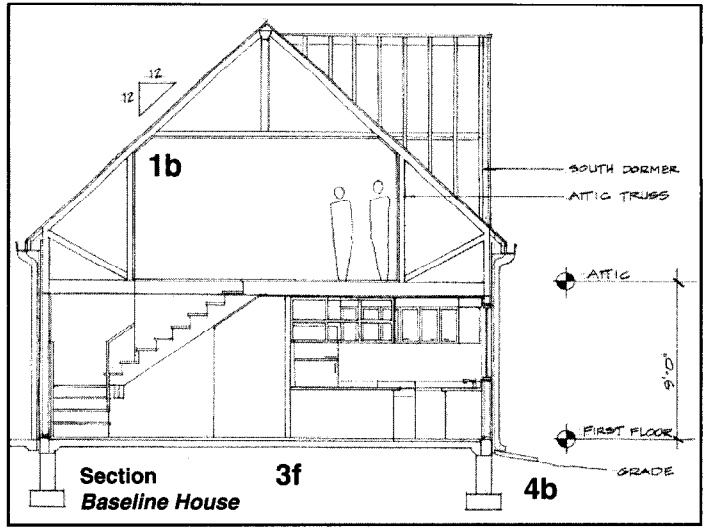
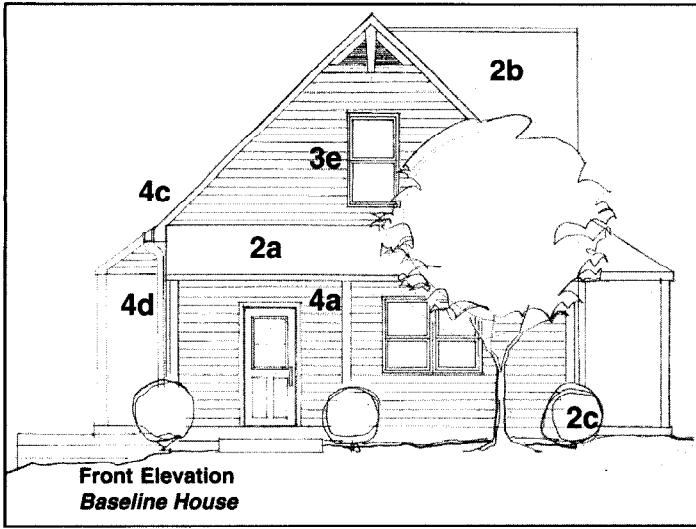

MADE-TO-LAST HOME BUILDING

Tools this manual provides:

- **Techniques for controlling hard costs of construction**
- **A method for managing home buyer expectations**
- **Information on financing options**
- **Sample *MADE-to-Last* home plans**
- **A template for a homeowner maintenance manual**

As part of the development of the MADE-TO-LAST Home Building Manual, the NAHB Research Center canvassed the home building industry to identify the main principles and features of attractive, affordable, durable **entry-level homes**. We brainstormed with a panel of housing experts, surveyed some of the nation's top affordable home builders, and reviewed statistics on home sales, characteristics, and durability issues. The result is an information package that will help you design, build, and present a lasting product that can compete in today's entry-level home market.

The MADE-TO-LAST builder manual has four major components.

1. Marketable Homes

This section of the manual provides:

- a discussion of the practices that successful builders employ in their affordable homes to increase marketability;
- main features that home buyers want in entry-level housing (as compiled from national surveys and a survey of leading affordable builders in the United States) and ways to market the features to buyers;
- an options-based approach for managing potential home buyer expectations; and
- information on educating buyers about financing options.

2. Affordable Construction

This section of the manual provides:

- a set of techniques and features that leading affordable builders use to control hard costs;
- real-life examples from builders who have successfully used the techniques and features to lower their costs; and
- examples of innovative approaches to lot layout and house siting.



3. Durability for Long-Lasting Homes

This section of the manual includes:

- construction techniques that address the most common durability issues; and
- guidance for developing a homeowner maintenance and durability manual.

4. The MADE-to-last Demonstration Home

This section of the manual includes:

- An example of the MADE-TO-LAST approach in the form of a demonstration home planned for the NAHB National Research Home Park. The preliminary plans for the demonstration home are included in the manual.

As a builder, you may be asking yourself, “Aren’t marketability, affordability, and durability often competing aspects of home building? Isn’t the most important aspect of an entry-level home simply price?” Read on to see how this manual can help you integrate marketability, affordability, and durability into an overall approach that demonstrates superior value to your home buyers—and gives you a competitive edge.

MADE

to Last

Cost Control Techniques

- **Smaller Homes
800-1,500 sq.ft.**
- **Efficient Framing
Techniques**
- **Innovative Materials**
- **Reduced Interior/
Exterior Details**
- **Fewer/Strategically
Placed Windows**
- **Cluster Development**
- **Manufactured Housing**
- **Innovative Foundation
Systems**
- **Purchasing Techniques**

Figure 1 - Cost Control

MARKETING THE MADE-TO-LAST HOME

MAJOR PRINCIPLES

This section of the *MADE-TO-LAST* manual presents six **significant marketing principles** that address the expectations of first-time buyers.

Cost Control

The cornerstone of marketing entry-level homes is, without question, price. There are many different approaches to keeping the price of a home to a minimum — Figure 1 provides a list of leading techniques. The most important thing is to identify techniques that reduce hard construction costs while having a minimal impact on quality and marketability. Case studies of builders who are successfully using these techniques are included in the Affordable Construction section of this manual (pages 23 to 40). Based on the savings identified in these case studies, a builder who incorporates all of the MADE-to-Last techniques could save as much as 15-20 percent on the total costs of production.

The most successful affordable builders will tell you that just because first-time home buyers are *especially* price-conscious does not mean that their selection of a home is driven *solely* by price. NAHB's *What Today's Home Buyers Want* identifies three additional items of particular interest to first-time home buyers: expandability, flexibility, and curb appeal. Although buyers often want much more than they can afford, they will frequently trade-off on their wish list for the ability to add features at a later time and for flexibility in the floor plan. In any case, the home must look attractive to the buyer.

Expandability

One of the chief methods for meeting the first-time home buyer's expectations and eventual needs is to provide for and show the buyer how you have built "future" features into their starter home. Those expectations might include more than one full bath, a third or fourth bedroom, a separate den or office, or a two-car garage. Small considerations such as the pitch of the roof, the placement of columns in the basement, or rough-ins for expansion can demonstrate to the first-time buyer that your attention to details builds more potential space into starter homes than might first appear.



Flexibility

First-time home buyers are looking for layouts that offer flexibility and permit combined use of rooms, along with ample overall square footage and storage space. This section describes some of the main ways to achieve flexibility in design.

Curb Appeal

NAHB surveys suggest, and the builders we contacted for this program confirmed, that flexibility and expandability cannot sell a home if the home itself is not attractive. There are several ways to make affordable homes attractive and individualize them to meet the needs of the purchaser. For example, this section describes issues such as treatment of the front entrance and roof lines.

In addition to the physical characteristics of the home, we have found that a basic understanding of certain issues must be translated to the buyers of affordable homes. The last two key principles are ways to educate your home buyers on the impact on costs of their expectations and on creative ways to finance their homes.

Expectation Management

The presentation of a baseline home that makes few assumptions regarding the “essential” elements of the starter home can be critical to the overall marketing strategy of affordable builders. Often called the “options” approach, this technique allows you as a builder to keep the home affordable in concept while permitting home buyers to judiciously select the most important features of the home within the limits of their budget. In addition to educating homeowners, you must ensure that your own staff and trade contractors support and understand these principles. All of your team should be able to outline your particular approach for entry-level, affordable housing to potential buyers.

Financing

Many potential home buyers do not realize that they can afford a new home. Educating home buyers about ways that qualify them to purchase your homes is one of the most important investments you can make.

Details on five of the concepts discussed above—*expandability, flexibility, curb appeal, expectation management, and financing*—are outlined in the following sections. *Cost control* is covered almost entirely in the separate Affordable Construction section of the manual.

EXPANDABILITY



FRONT ELEVATION

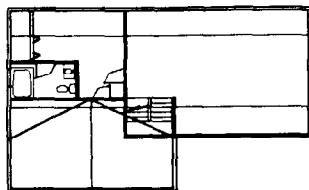

FINISHED ATTIC

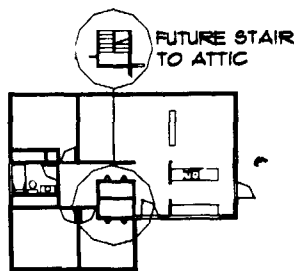

FIRST FLOOR

Figure 2 - Attic Space Design

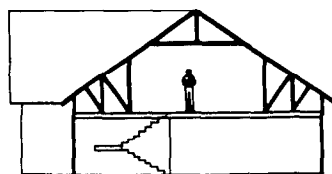

Figure 3 - Attic Truss

Survey results show that buyers will accept certain tradeoffs in exchange for a home that meets less than all of their expectations. One of these tradeoffs is the ability to expand the home at a later time. Expandability may be particularly appealing to buyers who view themselves as do-it-yourselfers. In selling expandability, you need to clearly demonstrate the home's potential for expansion and the value it adds to the buyer's investment. Expandability generally falls into two categories:

- providing unfinished interior space for future expansion; and
- providing for expansion outside the original structure.

Unfinished Interior Space: The Attic

In one-and-one-half story houses, the potential for expanding into the attic can be part of the affordable home design. The set of drawings in Figure 2 illustrates this concept. Many builders use *attic trusses* with the required roof pitch to achieve the necessary headroom for an attic expansion. You should also consider that the second-story window configuration should address daylighting and ventilation for the future living space (codes often require natural light from windows to represent 8 percent of floor area, half of which must be openable).

Although pull-down stairs for the attic space can help keep initial costs down, you should show buyers how the future permanent stairs will fit into their house plan. You may even treat construction of the finished stairs as an option, thereby giving the home buyer immediate use of the unfinished space for storage. Another option is to install spiral stairs. These stairs take up very little space, can be easily incorporated into a retrofit or remodeling project, and are relatively inexpensive and easy to install.

There are additional costs associated with unfinished attic space. For example, clear space attic trusses, as shown in Figure 3, come with a higher price than conventional roof trusses. Rough estimates indicate that attic trusses cost 25-35% more than conventional trusses of similar pitch. Important insulation considerations related to unfinished space also come into play. Another option for creating an unfinished attic is to use rafters. Although few affordable builders today stick-frame roofs – due to the cost and affordability of higher-skilled framers – the costs and benefits of this approach should be carefully considered.

Unfinished Interior Space: The Basement

One of the easiest ways to expand living space in a house is to finish a properly designed basement. Important considerations that will make the future conversion of the basement to living space easier are illustrated in Figure 4 and discussed below. These considerations can be marketed to the home buyer.

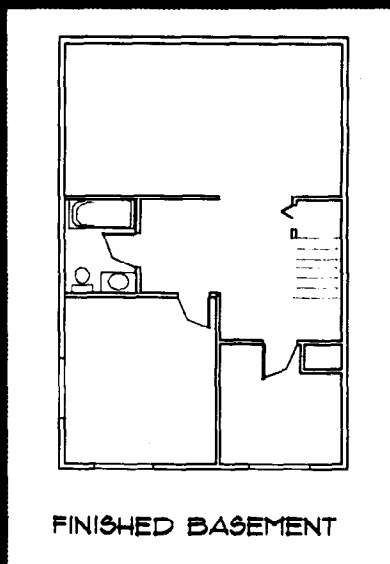
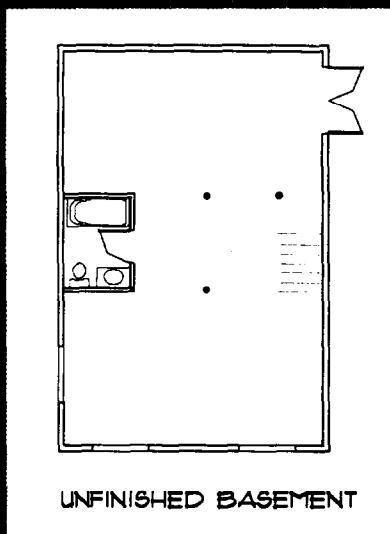
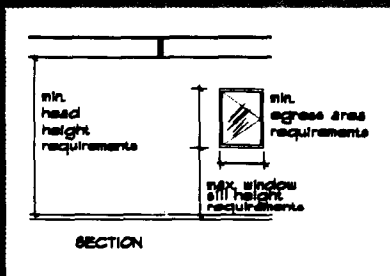

- **Floor-to-ceiling height** – Hanging the joists for the first floor deck from the side of a carrying beam, instead of overlaying, makes the basement space more usable and easier to finish when converted to a living space.
- **Location of support posts** – Typically, support posts for the carrying beam are simply placed at regular intervals along the span. By strategically locating the posts in relation to the basement stairs and the layout of future rooms (as shown in the middle drawing of Figure 4), the basement space becomes more usable and valuable.
- **Location of plumbing, sump pump, and electrical panel** – Consideration should be given to the placement of mechanical features typically located in the basement when planning for the future use of the basement as a living space.
- **Planned egress** – Every room used for a bedroom in a basement must have at least two means of egress in case of fire. At least one of the exits must be a door or stairway that creates an unobstructed path to the outside at street/ground level. Take full advantage of a sloping site with a walk-out basement. Not only does a walk-out allow useful access to the lower level, but it also offers the potential for additional natural light.

NOTE: Most codes require each bedroom to have at least one operable window. Generally, the sill height of the window cannot be more than 44 inches above the floor; the open area must be at least 5.7 square feet with a net clear opening at least 24 inches high and 20 inches wide. Windows considered as escape routes must have an open area on the outside if the elevation is below finished grade. These requirements vary somewhat with different codes. You should check with your local code official for specific requirements.



Figure 5 -

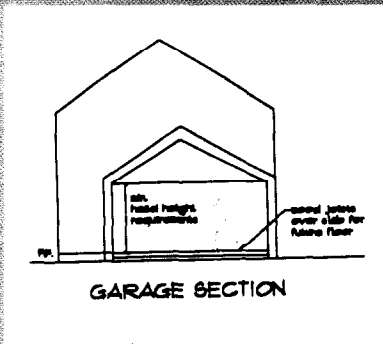

Figure 5 - Finished Garage Floor Assembly

Exterior Space: Garages and Carports

Attached garages offer several possibilities for expandable space in an affordable home. Attached garages are typically very easy to convert to finished space. Electrical panels are frequently located in the garage, making the installation of new circuits easy. Framing in garages is typically suitable for the installation of insulation and drywall.

Providing for future HVAC supplies in the garage area can avoid costly duct runs when the space is converted. Figure 5 illustrates conversion of an attached garage to a family room in a classic affordably-designed home. The garage can be an option or simply take the form of an open carport that lends itself to later enclosure. While garage or carport slabs need to be sloped for drainage, a reasonable elevation difference in the slope between slab and house can permit for future leveling with a thin concrete overlay or wood sleepers.

Alternatively, a raised floor over the garage slab can be added later. In this case, you must allow for adequate headroom above the new floor in your initial planning (see Figure 6).

Future Additions

As families grow, they need more space—an additional bedroom, an additional bath, or a family room. It is to the advantage of the affordable home builder to plan for future expansion. Consider the following when designing an affordable home for future additions:

- **Floor plan layout** – Layout of the floor plan is an important consideration. To give buyers a sense of circulation patterns and the practicality of the plans, show the layout as the home would look in the future with the addition of space as demonstrated in the series of drawings in Figure 7. These drawings illustrate expansion onto the rear, gable end of the house. Expansion to the rear of the house is typically the most practical option because it is usually where there is the most room for expansion.
- **Structure position on lot** – Location on the lot is also important. Your plans for future expansion should consider setbacks from lot lines and the relative locations of septic systems, wells, and other restrictions.
- **Structural framing modifications** – You may want to consider incorporating some structural framing modifications that will make a future addition easier. For example, you can place windows or exterior doors to allow for entry into the addition, or you might add a header for future use even if there is no door or window in the original plan. You can also plan roof lines to accommodate an addition located at a gable-end rather than at an eave wall, or simply permit a cleaner tie-in between the addition and existing house. A porch or deck, which could be enclosed later and turned into living space, can also be added.

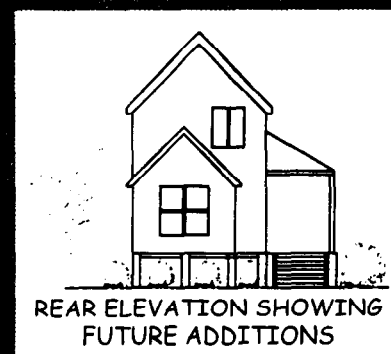
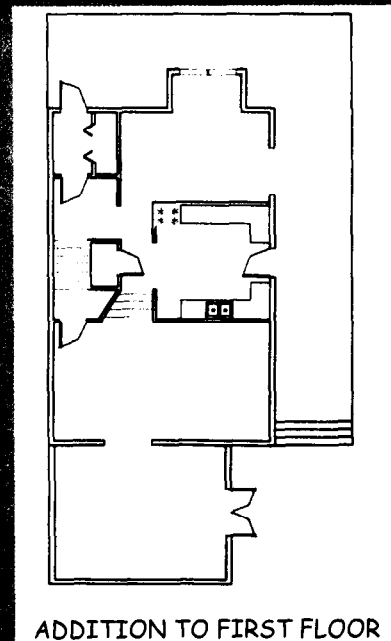
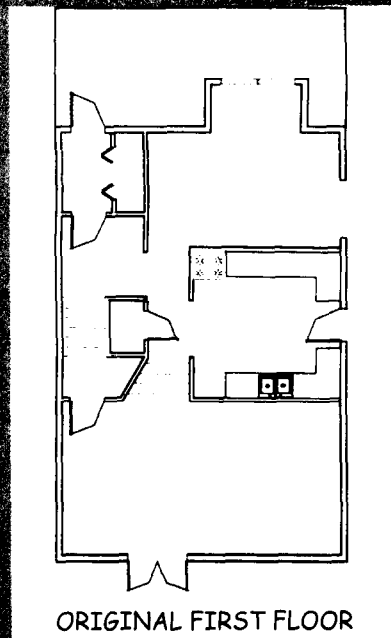

HVAC, Plumbing, and Electrical Considerations

Several of the expandability concepts require consideration of future heating, ventilation, air-conditioning (HVAC), plumbing and electrical equipment needs. Showing your clients how you have accommodated these needs can help sell them on the flexibility/expandability of your homes.

- **HVAC** – For all types of space conversion and additions, consider blocking out a wall for a “through-wall” HVAC unit or a rough-in for future duct extensions.
- **Plumbing** – The design of expandable space should include the placement of new plumbing near the old to save the cost of running long supply and waste lines. Ideally, new and old fixtures should be placed back to back along a common wall so they can share drains and supply lines. For a second-story expansion, a plumbing wall or a chase can accommodate existing and future plumbing. In many cases, expansion can take advantage of bathroom areas stacked over one another as shown in Figure 8.

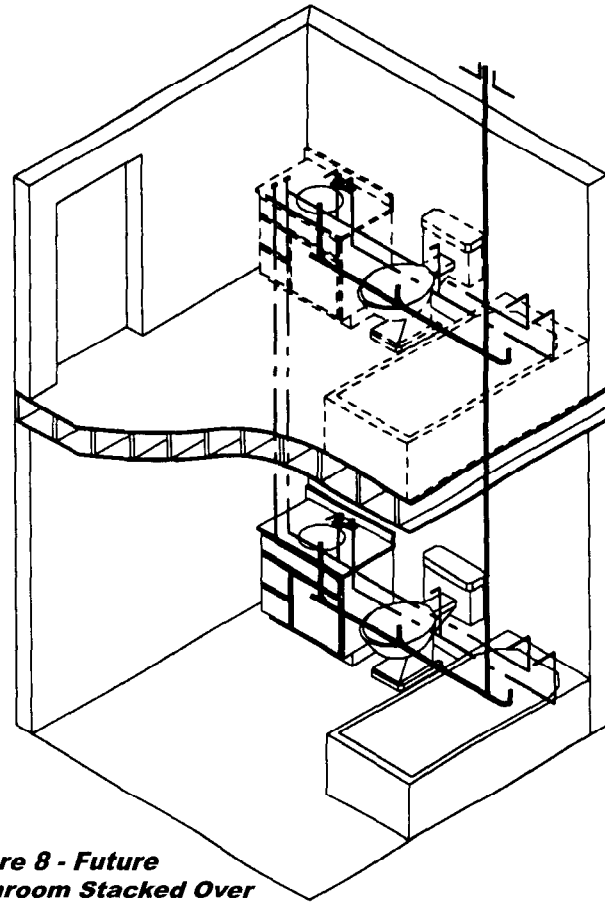
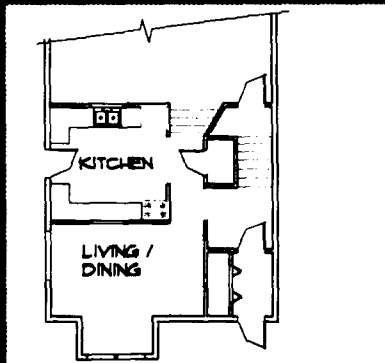
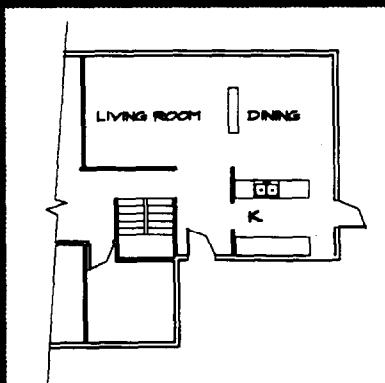

Figure 8 - Future Bathroom Stacked Over Existing Bath



FIRST FLOOR - EXAMPLE 1



FIRST FLOOR - EXAMPLE 2

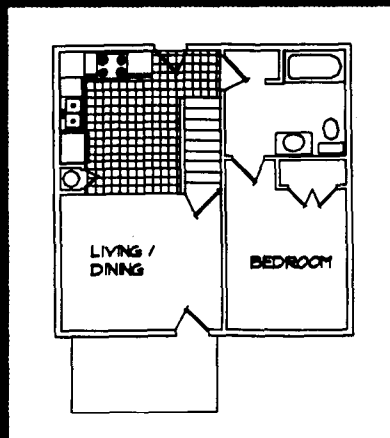

- **Electrical** – The sizing of the electrical service and panel should be considered with future expansion options in mind. Planning could allow for roughing-in branch circuits to walls adjacent to potential areas of future expansion. This is a relatively inexpensive undertaking and will avoid a significant expense during the construction of the addition.

FLEXIBILITY

Another approach to accommodating home buyers’ expectations and budgets is to build flexibility into your plans. In many cases, flexibility translates into a smaller, but highly functional home. You can consider a variety of options that provide flexibility.

Open Floor Plan

An open floor plan can create the impression of a larger home. The “great room” is perhaps the best example of this. The concept behind the great room calls for eliminating or reducing the partition walls between rooms. If desired, a sense of room division can be created with the use of cabinets, railings, changes in floor coverings, or even furniture placement. Example 1 of Figure 9 shows a large open space consisting of the kitchen and a combined living/dining area. Base cabinets are used to define the kitchen area. Example 2 of Figure 9 shows a large combined living/dining area without a partition dividing it. Fewer partition walls can also add up to savings by reducing framing costs and related electrical items.

Combined Use of Space

Combined use of space is similar to the open floor plan. The idea is to use spaces to serve more than one function. Many of the following concepts are illustrated in Figure 10:

- travelways through rooms, thereby eliminating hallways;
- direct entry from the exterior into a kitchen or living room;
- the country kitchen, which eliminates the separate dining room in favor of an eating area in the kitchen; and
- the great room, which combines kitchen, dining room, and family or living room into one larger space that serves as the social focus of the home and the practical center for preparing and serving meals.

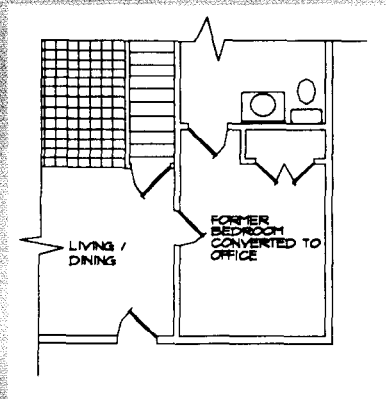

Figure 11 - Room Conversion

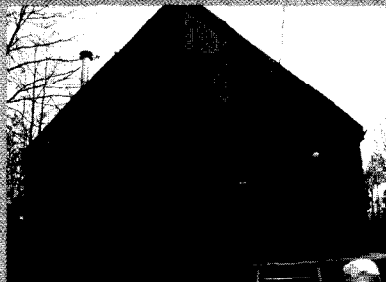

Figure 12 - Loft Space

Room Conversions

Many first-time home buyers value the ability to change their home around over time to accommodate changing needs. Changing the function of rooms to meet living, sleeping, and working requirements can be made easier when the initial home provides for future electrical and communication requirements, window and door locations, sound transmission, and storage capacity. It is important for you as the builder to discuss your buyers' needs with them before you determine what to offer.

Perhaps the most common example of converted space is the rough-in for a future bathroom. To meet buyer expectations for more baths, a master bedroom walk-in closet can be fitted with a rough-in for a future bath. Alternatively, attic storage space could later become a third or fourth bedroom or family room. Figure 11 shows the conversion of a first floor bedroom to an office. As with other recommendations, the degree to which you can include plans for space conversion will be dependent on construction costs, the lot, and other factors like restrictions on buildable area.

Another space that can be incorporated into a house to accommodate room conversion is a loft. The photos in Figure 12 present the front entrance and loft on the gable end of an affordable home (*NOTE: this loft space runs parallel to the ridge—it is more typical and generally more cost-effective to run the loft space perpendicular to the ridge for structural reasons.*) In many smaller homes, a loft provides flexibility because it can be used for so many purposes including a family room, office, guest room, exercise room, or high-access storage. The installation of circular stairs can be a cost-effective and space-saving way to access a loft.

Accessible Design

While it may not be practical or cost effective to make an affordable home completely accessible, builders can make and market accessible features that add appeal to many potential buyers.



Typically, these provisions include minor low cost alterations to the ground level of the home such as:

- providing 36" rather than 30-32" openings to bathrooms and living areas
- avoiding narrow corridors which may be difficult to maneuver
- incorporating a second bedroom on the first floor or other features that enable single-level living

The relative cost of these features can be kept low if they are considered in the initial design of the home. As an example, see the MADE-to-Last demonstration home plans. Given the increasingly diverse and aging population, accessibility can be an important marketing feature.

CURB APPEAL

All home buyers want their homes to be distinctive and attractive. Affordable homes can be designed and built with elevations that are just as attractive as those that distinguish more expensive homes. In fact, some technological advances (e.g., roof trusses and related design software) have given the affordable home builder more flexibility than ever before in designing homes with substantial curb appeal.

Entry/Porch

A home's front elevation is the most important to all home buyers. Doors and windows on the front elevation add character and help create a style for the house. Front doors define the approach to the house and give the home a sense of individuality. A well-placed entrance with a good view of the street adds to the security of the house and neighboring properties.

The street elevation becomes more inviting with the addition of a front porch. A porch provides a transition from the outside to the inside. It also provides protection from the elements, increases total living space, and enhances the entrance. Figure 13 shows two very different approaches to the incorporation of a front entrance sheltered by a porch.

Variations To Roof Line For An Affordable House

The most visible characteristic of a house, especially when viewed from a distance, is the roof line. Diversity in the roof shapes of neighboring houses adds to the visual appeal of a residential development. A unique roof adds distinction to the home which is important to many home buyers.

While the best guideline is to keep the roof line simple, many of today's truss configurations can add variety to the shape of the roof with little additional cost. The top photo of Figure 14 demonstrates the architectural impact of a small gable pop-out and the single gable peak trim detail. Trusses with a steeper slope or hip roof are also available at little extra cost, particularly when a builder relies on a set of standard designs. To add distinction to the front elevation of homes, affordable home builders often incorporate variations such as small entryway roofs as shown in the bottom photo of Figure 14.

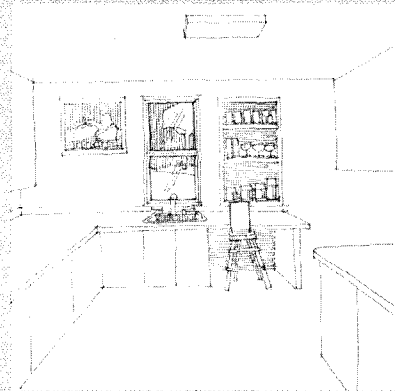

Figure 15 - Effective Window Placement

Window And Door Placement

The placement and sizing of windows and doors is critical to the aesthetic balance of the house and its overall appeal. Accordingly, it is important not only to provide an aesthetically pleasing product, but also deliver a functional home whose windows provide security and privacy. The effective placement of windows can maximize natural light to enhance certain interior spaces, especially the kitchen and other work areas, as demonstrated by the single window in Figure 15.

“Value-added” features for windows can also be promoted to buyers. Windows can mean long-term benefits for heating, cooling, and daylighting the house and can enhance the quality of the interior spaces while lowering utility bills. For example, moderate amounts of low-E glass facing south improve comfort levels during the heating season. Strategic placement of windows and doors can also add to the home's future flexibility by providing openings onto a future porch, deck, or into an addition.



Figure 16 - Simple Strategic Landscaping

Landscaping

Landscaping can be an effective tool for enhancing curb appeal. A few strategically placed plants, shrubs, or trees can transform the look of a home. Figure 16 illustrates how the modest use of shrubs, mulch, and fencing sets off the home.

Landscaping offers secondary benefits. The proper selection of vegetation types can allow summertime shading of the house while allowing wintertime solar gain and daylighting. Landscaping with plants, fences, and walls or even the placement of neighboring houses can also provide a buffer against winter winds while enhancing privacy.

With landscaping installed near the foundation, it is important to leave enough room to accommodate for future growth of the plants. In addition, the grading plan should be designed so that plants do not impede the flow of surface water away from the home.

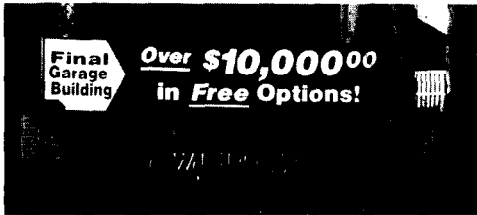
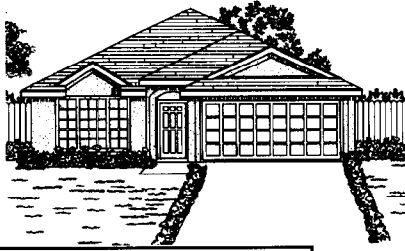

Figure 17 - Market Creep

When affordable home builders are asked what they put into their homes to make them affordable, they frequently respond that it's what they *don't* put in that makes their houses affordable. It is difficult to explain to potential home buyers, however, that the home they can afford is often smaller and has fewer windows and baths than what they expect or desire. Indeed, these items are almost always a part of an "options" approach to marketing the affordable, entry-level home. By making the fewest number of assumptions about what features the first-time home buyer considers essential, the builder has the opportunity to:

- control the "market creep" of "standard" features, whereby costs climb upward as more and more optional features are viewed as standard items (see Figure 17);
- educate the buyer regarding the price of specific home features; and
- assist the buyer in making the educated trade-offs necessary to keep the home affordable yet still functional and appealing.

The options approach requires a detailed examination of home design and features. You need to identify the various options, and be able to show the homeowner the cost impact of each item. After buyers come to terms with the real cost of items, they find it easier to make choices about what they want and need in their home. A clear presentation of the "options" approach allows purchasers to make more accurate comparisons between your homes and your competitor's. The profile on Centex Homes (page 18) describes how one large production builder employs the "options" approach in building and marketing affordable homes.



Builder: Centex Homes
 Dallas, TX
 Randy Luther,
 Director of R&D

Homes: 1,500 square feet,
 one-story, slab-on-
 grade

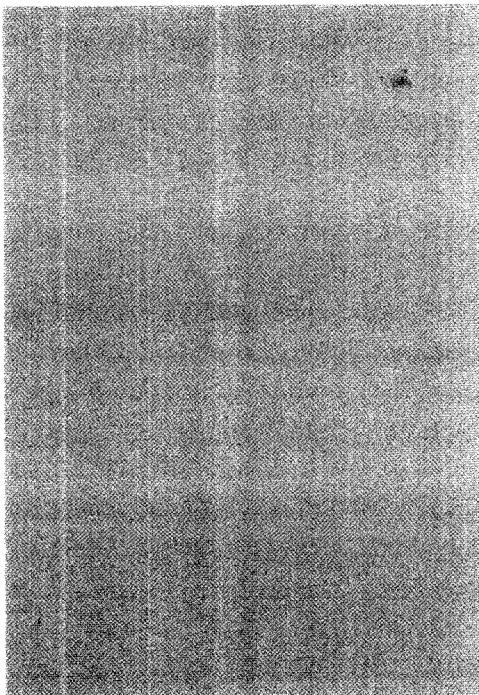

Profile: Market Creep
Savings: \$10,000

“Market creep was pricing our homes beyond the income of the families they were designed for. We were losing market share.”

Approach

During the housing boom of the late 1980s, many optional features became standard features as a way to attract potential buyers. When the market cooled down the higher sales prices reduced Centex’s targeted market share. Within each income group, focus group results identified the standard features that consumers viewed as optional. Revising every model’s base price and options list helped customers better understand the costs associated with all the features they were considering. The result was improved affordability. Central to this approach is training sales staff to “educate” the home buyer in how to make smart, tough choices.

Results

Centex was able to lower its average sales prices by about \$10,000 per model. The lower prices opened all of Centex’s homes to the entire income group for which the homes had been originally designed.

FINANCING

Many first-time home buyers do not realize they can afford a home and continually postpone home-buying decisions. The belief that you must have a large down payment to get into a home is still very common among many potential first-time home buyers. Builders must equip themselves with the knowledge to dispel these myths. Builders should be familiar with the myriad of financing sources available and take steps to educate potential buyers.

The conventional mortgage market meets the needs of most home buyers; however, many first-time buyers or lower income buyers need access to lower cost or more flexible financing opportunities, second mortgage loans and other assistance. This assistance may already be available in your area and may be easy for borrowers to obtain. In fact, much of this assistance combines private lender funds with government insurance, guarantees and subsidies and is available through private lenders, state and local housing agencies and community-based non-profit organizations. Such entities also offer technical assistance and counseling to help home buyers through the financing process.



Several of the more common affordable financing programs are described below.

Private Lenders – Many private lenders are deeply involved with loans for affordable housing. They try new approaches, incorporate more flexible underwriting and pricing, and take new risks. Many lenders offer loans insured through the Federal Housing Administration (FHA) and the Veterans Administration. These loan programs are some of the most popular and widely available programs available to entry-level home buyers. They commonly require lower downpayment and offer more liberal underwriting criteria for entry-level buyers on homes priced below a locally determined ceiling. Other affordable lending options are available through members of the Federal Home Loan Bank system. Members, which include commercial banks, savings institutions, credit unions and insurance companies, can access lower interest funds and grants from the regional home loan banks and make these funds available to qualified borrowers.

State Housing Finance Agencies (HFAs) – HFAs, which operate in every state, issue tax-exempt bonds and use the proceeds to provide mortgages, through private lenders, to low and moderate income purchasers of modest priced homes. These loans have interest rates as much as 2.5 percentage points below conventional rates resulting in savings of as much as \$100 per month. HFAs also offer hundreds of other homeownership financing programs that provide technical assistance, low and no interest loans, second mortgages and grants.

Public Funding – Funds are often available at the state and local level to be used for first and second mortgages at rates based on the home buyer's ability to pay. Interest rates generally range from 0 percent to market level. The most widely used programs are the Community Development Block Grant (CDBG) program and the HOME program.

Community-Based Non-Profit Housing Organizations - One or more of these may operate in your area. Such organizations typically focus on low and moderate income first-time home buyers and offer technical assistance, loans and grants. The organization may be affiliated with a national non-profit intermediary such as the Enterprise Foundation, the Local Initiative Support Corporation or the Neighborhood Reinvestment Corporation from which they can access additional financial support.

HELPFUL CONTACTS
National Council of State Housing Agencies (202) 624-7710 ncsha.org
Federal Housing Finance Board (202) 408-2500
Local Initiatives Support Corporation (212) 455-9822
The Enterprise Foundation (410) 964-1230
Neighborhood Reinvestment Corporation (202) 376-2400
National Foundation for Consumer Credit (301) 589-5600
Federal National Mortgage Association (Fannie Mae) (202) 752-7000 fanniemae.com
Federal Home Loan Mortgage Corporation (Freddie Mac) (800) 373-3343 freddiemac.com
Federal Agricultural Mortgage Association (Farmer Mac) (800) 879-3276 farmermac.com

Figure 18 - Helpful Financing Contacts

Non-Traditional Lenders – These financial institutions work in many areas of the country. At the state and local level they include community loan funds and non-profit housing lenders such as the Community Development Corporation in New York or Self-Help Housing in North Carolina. At the national level they include the non-profit intermediaries cited above.

Although some of these non-profit and non-traditional lending sources may not be available for the average for-profit builder, the possibilities are still worth investigating. There may be potential to partner with a non-profit or community based organization in the production of affordable housing.

WHERE TO GO FOR HELP:

Your first step in learning more about available financing opportunities is to call your state and/or local (city or county) housing and community development department which often serves as a clearinghouse for housing information in your area. Many state HFAs also play this role. Ask to speak with the person responsible for affordable homeownership programs. These individuals are knowledgeable about programs administered by their agencies and other public and private organizations in their jurisdictions. Ask them to send you any written information about available programs including their marketing brochures. Ask also if there are any non-profit organizations, including housing counseling agencies, that are concerned with homeownership and operate in your area. Call those organizations and find out how they can assist your home buyers.

Once you have obtained information on the programs available in your area, you might want to:

- create an information package;
- provide buyers with loan calculator cards that are available from most lending institutions or real estate agents;
- let buyers see how the “options” they want can affect their costs and even their ability to qualify for financing;
- consider self-financing options (see Appendix A for a sample program)
- consider funding a portion of the closing costs

USEFUL REFERENCES

NOTE: For more information on how to order these publications, contact the HomeBase Hotline at (800) 898-2842 or visit pathnet.org on the internet.

- *What Today's Home Buyers Want*, National Association of Home Builders & Fulton Research, Inc. in association with Housing Guides of America, 1996.
- *Industrialized Housing: Final Report*, NAHB Research Center for U.S. Department of Housing and Urban Development, August, 1998 (provides valuable information on the costs of site-built, modular, and manufactured homes).
- *Street of Affordability* - Fredericksburg (Virginia) Area Builders Association, Spring, 1997 (for more information on this annual marketing event for affordable builders call 540-898-2730).
- "Smarter House for the Money", *Professional Builder* article series by Anne O'Reilly, near monthly articles - February, 1996 through February, 1998.
- *Report of the City Housing Task Force*, NAHB, January, 1998 - A report of the Mortgage Finance Department of NAHB (useful case studies of affordable housing projects in urban settings).

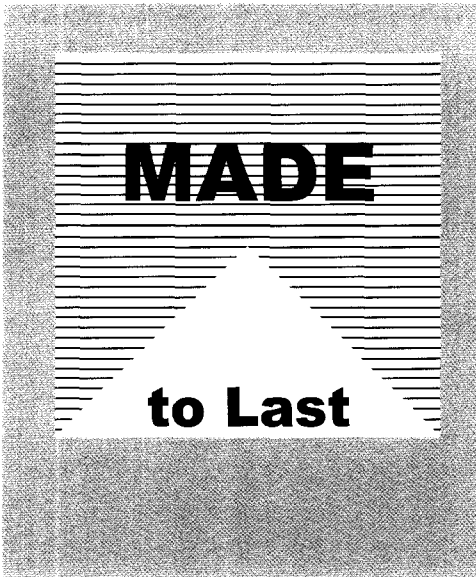

AFFORDABLE CONSTRUCTION

While holding the line on the hard costs of construction is important in all homes, it is critical for the entry-level home. There are a number of different ways in which affordable builders can minimize construction costs and still deliver a marketable product.

- **Land development** – No discussion of affordable housing and potential cost-savings would be complete without addressing the cost of land and related improvements. Contending with these issues is probably one of the most formidable challenges that affordable builders and developers face. Although most of the issues surrounding land development are beyond the scope of this manual, Appendix B presents a summary of key ideas which builders should advance in local forums to streamline land development approvals.
- **Planning and design** – The layout of an affordable home, even with respect to adjacent homes, can have an enormous impact on costs especially with regard to utilities and the rooms they serve. And most affordable builders will tell you that it is the features that they strategically leave out of their homes that have the greatest impact on affordability. As a general reference, Figure 19 (pages 23 and 24) presents a cost breakdown of a typical affordable home.
- **Innovative building materials and techniques** – More and more builders are considering innovative building products in lieu of conventional materials to reduce costs. It was not that long ago that vinyl siding made its debut as a cost-effective substitute for more traditional cladding materials. Today materials such as residential light gauge steel framing and insulated concrete forms are gaining acceptance in certain markets and applications. Although the initial cost of many new materials can exceed that of conventional materials, many builders have willingly accepted this to gain potential labor savings and to increase the quality of their homes.

Many innovative materials are getting a boost from joint government/industry research efforts. For example, *The Prescriptive Method for Residential Steel Framing*, the product of cooperative research involving HUD, private industry, and the NAHB Research Center, provides span tables and standard construction details which make it easier and less costly to frame with steel.

Affordable House Cost Breakdown

Expense	Cost in Dollars
Initial Costs	
Survey/Pilot Plans	175
Designing	225
Permits	
Building Permit	400
FHA Inspection	180
(Compliance Inspections - 3 @ \$60 each)	
Excavating	
Basement	350
Backfill/Rough Grade	325
Final Grade	350
Cement/Asphalt/Stone	
Foundation Walls	2,660
Interior (Basement)	1,360
Exterior (Drive/Walk)	2,100
Lumber	
Rough	5,400
Trusses	1,050
Doors/Trim	1,775
Roofing	
Labor	300
Material	595
Doors/Windows	
Windows	2,095
Exterior Doors	200
Crane/Steel	
Crane	145
Carpentry	
Rough	2,785
Interior Trim Labor	1,050
Plumbing	
Undergrounds	3,850*
* 1997 Plumbing includes all plumbing up to 35' of water & sewer	
Gas/Electric	
Gas Service & Usage	275
Electric Service	275
Rough	2,450
Phone Jacks	40
Fixtures	550
Heating	
Rough (Transfer grills)	2,850
Trash	
	500*
*Total Trash cost including rough, middle, final & dumpster	
Insulation	
Walls	680
Blown	400

Figure 19 - Greater Grand Rapids Home Builders Association Cost Breakdown

A new federal initiative, Partnership for Advancing Technologies in Housing (PATH), will bring the public and private sector together to develop, implement, and promote innovative technologies which improve the quality, durability, energy efficiency and affordability of housing. Affordable home builders should stay informed about these types of programs for the latest on new technologies they can employ to cut costs and improve their product.

- Factory housing** – One form of housing innovation is taking place in the old “mobile home” market. Manufactured housing plants are producing larger, more energy-efficient, and more sophisticated one, two, and even four-unit stacked homes. As a recent NAHB Research Center report to HUD indicates, the manufactured housing producers are improving their product offerings while maintaining average hard costs of construction of about \$20 per square foot in comparison to nearly \$33.50 for similar site-built housing. The graph in Figure 20 shows the increasing market share that manufactured housing is achieving. Affordable site builders can look to better distinguish their products from manufactured housing products, investigate the cost-control advantages of pre-assembly, or consider introducing manufactured housing into their product line.

Expense	Cost in Dollars
Drywall	
Hang/Finish	3,150
Painting	
Interior	1,750
Siding/Shutters	2,500
Cabinetry	
Cabinets	1,100
Marble Tops	200
Formica	300
Flooring	
Vinyl & Underlayment	650
Carpet	1,575
Other Final Costs	
Shelving	125
Mirrors	75
Hardware	100
Appliances	-0-
Punch Out	150
Interior Cleaning	160
Miscellaneous	550
Overhead/Admin/Hard Cost	6,540
SUBTOTAL	54,495
Special Costs	
Sewer Permit	1,600
Profit	4,979
Marketing Fee	3,000
TOTAL RETAIL COST	64,074

(Real Estate Transfer Tax — not included in cost — .75% to State, .11% to County)

COST CONTROL

In order to keep costs under control, builders recommend offering limited choices to the customer in the following areas:

- Roof shingles
- Siding color
- Interior paint color
- Carpet quality and color
- Kitchen and bathroom cabinets

The Cost Breakdown was used to determine the cost of the Affordable Home without a garage. These figures are simply a guide. Remember, costs will vary from builder to builder and city to city.

The Greater Grand Rapids Home Builders Association developed this suggested plan, but the responsibility and liability for building this home is the responsibility of the licensed contractor. Rev. 2/97

Figure 19 (continued)

Manufactured Housing as a % of Total Single Family Detached Housing

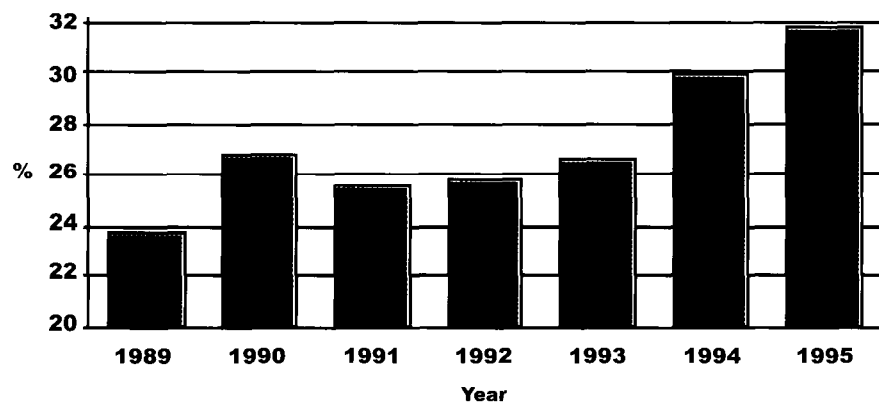
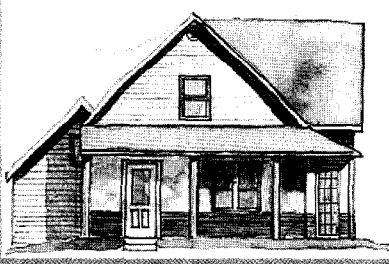

Figure 20 - Manufactured Housing Growth



The methods detailed in this section of the MADE manual are, for the most part, code-approved, time-tested, and commercially available. Some have been around for awhile and deserve a closer or second look by affordable home builders to address changes in energy-efficiency standards, waste disposal costs, labor rates and availability, and material costs.

As you review the affordable construction ideas presented in this section, consider how you might invest any potential savings for the homeowner. Savings from these concepts can allow you to offer homes at lower first cost. Alternatively, lower construction costs may be used as a marketing tradeoff if they are reinvested in more durable/lower maintenance materials and construction details which reduce the long term costs of the home to the buyer. Use your MADE approach to home building to work with the first-time buyer on these decisions.

LOT SIZE/PLACEMENT OF HOME

The lot size and placement of a home—and the associated costs—are often determined before a builder purchases a lot. Nonetheless, builders can consider some land planning strategies to help create more affordable housing. One important consideration is that traditional development layouts do not always yield the most affordable building lots. Therefore, builder and developers should be willing to consider alternative approaches that can increase density or otherwise lower costs.

Clustering homes within a small area of the overall development parcel is an important option. Clustering can reduce development costs by minimizing the amount of roads and utility mains that have to be constructed. Further, environmental interests often look favorably on clustering because it disturbs less land.

Profile: Cluster Development
Savings: \$10,000 to \$15,000

“By detaching the units, we’re setting them apart from others. There’s a definite feel of a single-family home rather than a townhouse.”

Approach

In a cluster development, units are grouped together in a manner similar to townhouses, with the exception that the units are not attached. In Woodhill’s community, only six feet separates the units. Nonetheless, strategically placed windows eliminate sight lines into adjacent units and provide a sense of separation. Garages are grouped together in parking areas at the rear of the units. Maintenance of common areas and garages is funded by a \$60 monthly homeowners’ association fee.

Results

By using cluster development, the Woodhill Corp. was able to

- increase the marketability of its units, especially compared to townhouses;
- provide larger, undisturbed common areas; and offer selling prices approximately \$10,000 to \$15,000 below comparable single-family units.

Builder: The Woodhill Corp
Joliet, IL

John Barcelona,
President

Homes: 1,000-1,400 square
feet, two-story, slab-
on-grade

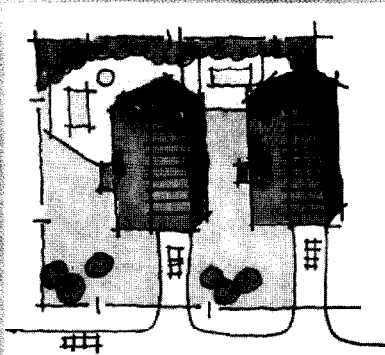

Zero Lot Lines

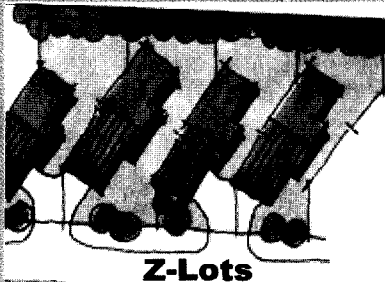

Z-Lots

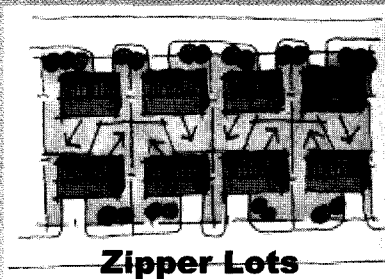

Zipper Lots

Figure 21 - Alternative Lot Layouts

(used by permission: Architecture Magazine, June 1991, James W. Wentling/Colleen Brogan.)

One of the most efficient uses of land is through **high-density housing**. Don't write off townhouses or other attached housing such as duplexes, triplexes, or quads. In many cases, a mix of detached and attached homes provides an optimal layout.

Placement of the home on the lot can also offer opportunities for cost savings (see Figure 21 for three land-conserving layouts). For example, the **zero-lot-line** house makes more efficient use of sideyard setbacks. The home is set on the side property line as opposed to the center of the lot, leaving a larger and more usable side yard on the opposite side. As with any deviation from tradition, you need to check that local zoning or development ordinances permit the zero-lot-line configuration. You also need to take into account potential added costs in other areas such as fire walls that are typically required by building codes when homes are sited along the lot line.

Other approaches also help small-lot housing look more appealing and less like multifamily developments. For example, the **Z-lot** or angle-lot rotates a narrow lot and exposes more of the house perimeter to the street. This arrangement was intended to improve on the front facade of the zero-lot-line house, which is typically a garage, by providing more habitable area and a recognizable entrance. Another example is the **zipper lot**, which uses wide shallow lots by off-setting space in the rear of the lots.

MANUFACTURED HOUSING

Manufactured housing can represent a challenge or an opportunity to affordable site builders. Builders can recapture some of the affordable market share manufactured housing has acquired by:

- marketing the differences between site-built and manufactured housing—permanent foundations, customization, flexibility and expandability, and durability; or
- investigating entry into the manufactured housing market. Take advantage of your expertise in land development, financing, and marketing.



Builder: Corridor I, LP
Columbia, MD
Joseph Link,
Marketing Consultant

Homes: 1,005-1,535 square
feet, one- and two-
story full basement

Profile: Manufactured Housing

“Teamwork and technology are the key to affordability at New Colony Village.”

Approach

New Colony Village recognized the market for affordable single-family detached housing in affluent Howard County, Maryland. They were able to obtain approval for a 416 unit development which would feature manufactured housing. These manufactured homes are equipped with an integral chassis system that allows for the stacking of modules to form 2-story units. The developer utilized mobile home zoning to achieve a density of 14 units per acre with single-family detached manufactured housing units.

New Colony Village was developed as a gated, land lease community. Included in the lease is the maintenance of common areas, parks, and a community center containing fitness facilities, a pool, and a daycare center.

Results

By incorporating these innovative development and construction techniques in New Colony Village, Corridor I, LP was able to produce quality affordable housing for \$109,990 to \$132,440, well below the county’s average sales price for single-family homes of \$273,000. In addition, the land lease allows home buyers to acquire a new home at a fraction of typical closing costs.

ROOM LAYOUTS

The layout of rooms in a home can affect costs in several ways. First, with careful planning, building and room dimensions can be designed in two-foot increments to reduce the waste of material cutoffs (see OVE section under framing). Second, open floor plans can reduce the number of interior partitions. Third, kitchens, baths, and laundry areas can be grouped together or stacked to minimize plumbing costs.

KITCHENS AND BATHS

Kitchens

- Increase usable counter space through attachment of appliances to the underside of wall cabinets. Running cabinets to the ceiling can provide substantially more cabinet space in a smaller kitchen.
- Consider a pantry with a door to reduce the number of finished cabinets and to increase useful access to stored kitchen items (see Figure 22).
- Consider open shelving in place of cabinets where appropriate (see Figure 23).
- Consider not including all “standard” appliances, i.e., dishwasher, in-sink disposal, etc.
- Consider single-bowl and single-lever sinks without the sprayhose.

Baths

- Consider a shower stall in place of a tub.
- Consider a half-bath in place of a full bath.
- Minimize cabinetry.

In many cases, the items above are difficult to sell to buyers by simply talking about the associated cost savings. You need to demonstrate either through photographs or drawings that the final product remains attractive and functional.

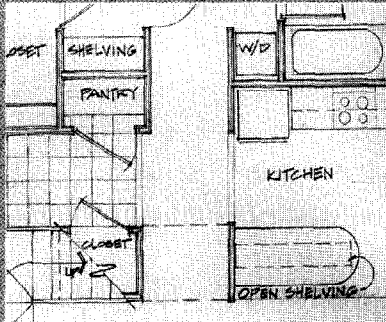

Figure 22 - Walk-in Pantry

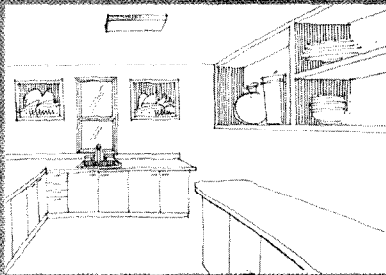

Figure 23 - Open Shelving



Profile: Strategically Placed Windows
Savings: \$1,100

Builder: Sawbuck, Inc.
LaGrange, OH
Lee Holztrager

Homes: 1,000 square feet,
one-story, slab-on-
grade

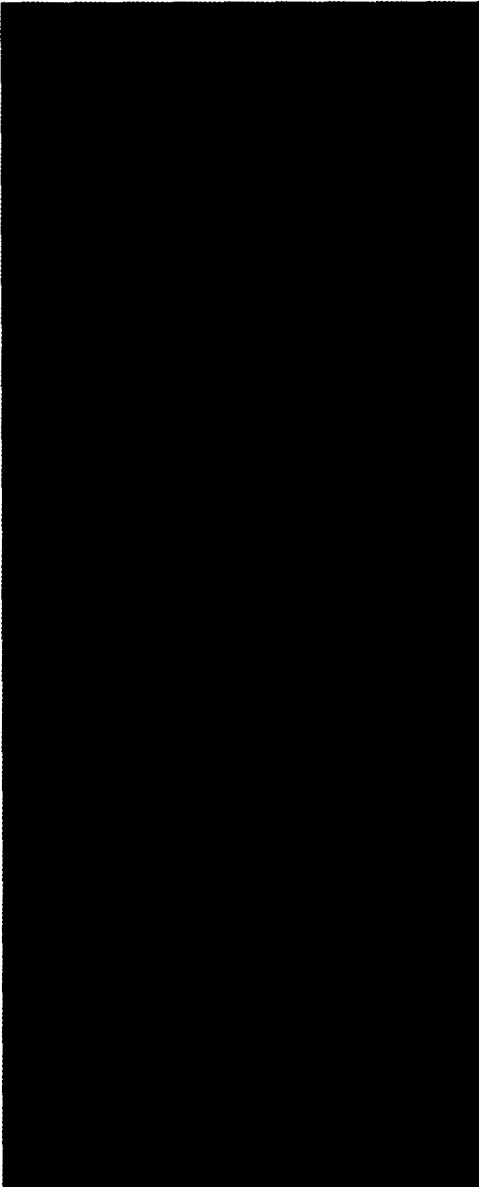

“We build an affordable home with only five windows and two doors. Our customer is happy and we meet code requirements.”

Approach

Cost reduction goals and narrow lot widths mean that Sawbuck now builds homes with five windows. Eliminating side windows provides the residents with added privacy. For example, an offset bedroom window permits a bed to be placed against the wall such that the headboard does not block the bottom of the window. The homeowner notices and appreciates Sawbuck’s attention to detail.

Results

Reducing the number of windows from an industry average of nine to code-approved five has reduced Sawbuck’s costs by approximately \$1,100.

Selection and placement of windows and doors is an important factor not only with respect to cost but also with regard to appearance of a home. Use standard window and door sizes rather than unusual shapes or sizes. For example, side-by-side placement of multiple, smaller size standard windows is often much less expensive than larger windows, and it can provide a similar visual effect.

Remember that most of a home’s curb appeal is related to the appearance of the front elevation. Consider whether additional windows on rear and back elevations are necessary beyond those needed for egress, light, and ventilation. Ask yourself and your buyers the same questions about additional doors, expensive hardware, doorbells, window trim, or even that automatic garage door opener.

FOUNDATIONS

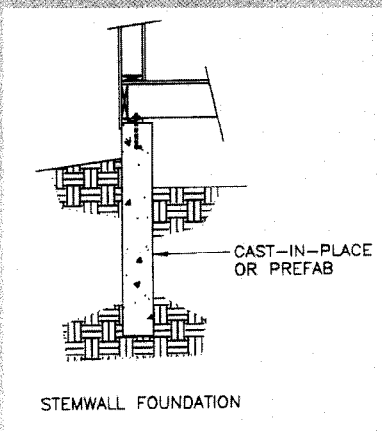
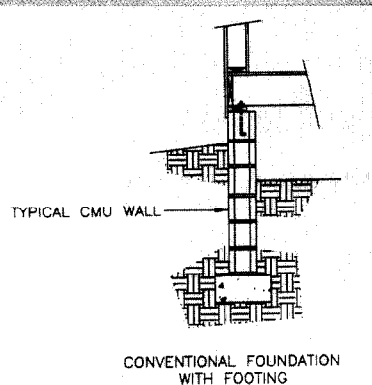
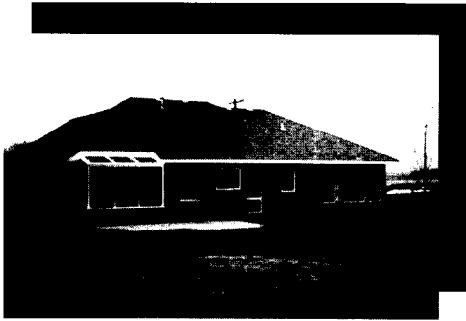

Figure 24 - Stemwall Foundation

Technologies related to reducing the cost of foundations have been available for many years, but have not yet found widespread acceptance. In many cases, building codes have only recently acknowledged alternatives to conventional foundation systems. In other cases, the local market has not been receptive to the alternatives. Some examples of alternative foundation technologies are discussed below.

- **Slab-on-grade foundations as opposed to a basement** – Although many buyers and builders agree that a basement is a desirable feature, slab-on-grade construction on many lot types can allow a home to be built at a much lower cost than with a conventional foundation. Of course, any alternative involves tradeoffs. For example, you may need to provide additional above-grade space for storage. As for builders who already use slab-on-grade foundations, they can cut the costs of the slab even further by building a monolithic slab and footing, thereby reducing the need for separate inspections and trades for each operation.
- **Stem wall foundation** – The stemwall foundation is designed to distribute building loads to the soil without the need for a separate footing (see Figure 24). It can be used for both full-basement and crawlspace foundations. Cast as a single unit, the stemwall foundation is particularly well suited to smaller homes built on most soils.



Builder: Bill Eich Construction
Spirit Lake, IA

Bill Eich, President

Homes: 1,200-3,000 square feet, two-story, slab-on-grade, full basement

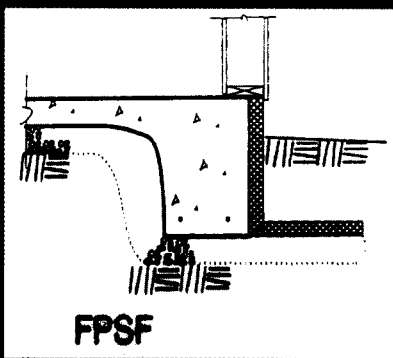
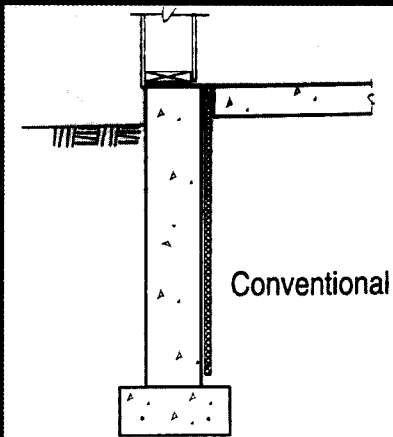

Profile: Frost-Protected Shallow Foundations
Savings: \$4,000

“We incorporate Frost Protected Shallow Foundations [FPSFs] in some way in almost every home we build. The concept is so simple. Rather than installing our footings 48 inches deep, below the frost line, we insulate the ground around the perimeter of our homes with enough foam insulation to permanently raise the frost line. We make the footings think they are in Florida, and if they think they’re in Florida, they only have to be 16 inches deep!”

Approach

Bill Eich has been using FPSFs for over 12 years and has completed over 200 homes using this technology.

Bill Eich uses FPSFs on almost every home he builds. On houses that have basements, FPSFs are used for the garage slabs and on the above grade portion of walk-out basements. The use of FPSFs provides a substantial savings over the conventional deep footings that are required in cold climates such as in Iowa. They also provide home buyers with a warm floor even on the coldest days.

Results

By incorporating FPSFs, Bill Eich Construction has been able to save over \$4,000 on the typical affordable slab-on-grade home versus the conventional crawlspace.

- **Frost-Protected Shallow Foundation (FPSF)** – Pioneered in Scandinavia to reduce the cost of foundations in areas with deep frostlines, the FPSF uses strategically placed insulation to limit the depth of the foundation and thus lower cost (see Figure 25). Criteria for FPSF design in the United States are now available and are included in some of the major U.S. building codes. In addition, the American Society of Civil Engineers expects to release a consensus standard on this type of construction shortly.

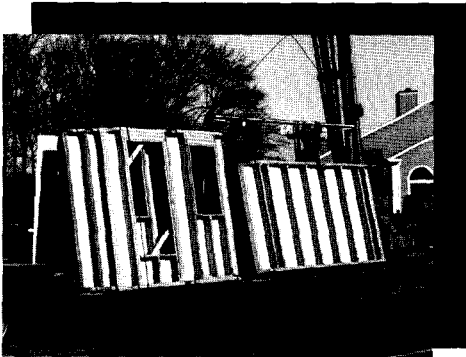

Builder: Northern Enterprise
Home Manufacturing
Hartford, CT

Krish Naraine,
General Manager

Homes: 2,800 square feet,
two-family, two-story
with full basement

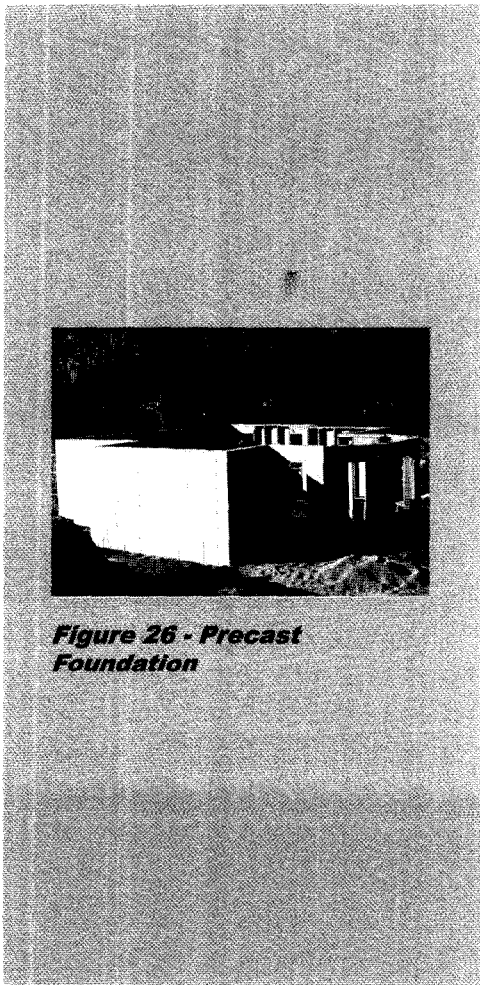

**Figure 26 - Precast
Foundation**

**Profile: Precast Foundations
Savings: \$1,700**

“The pre-cast basement wall system provides an energy-efficient system which goes in quickly, a plus in inner-city neighborhoods.”

Approach

Krish Naraine, a community builder for 10 years, recently formed Northern Enterprise Home Manufacturing to build affordable, inner-city housing. Mr. Naraine believes he can build energy-efficiency into his homes to keep monthly utility costs down for low and moderate income homeowners.

Pre-cast foundation walls are part of the strategy to keep energy costs low. These walls incorporate an R-5 rigid foam insulation and can readily accept R-19 fiberglass batts. Mr. Naraine also likes the foundation system’s 15 year warranty against water intrusion and structural defects. Another feature Mr. Naraine likes is the expandability of the basement into conditioned living space.

Results

Using the energy-efficient foundation was an important aspect of the energy-efficient envelope which helped win the City of Hartford Redevelopment Project. It will also speed up the construction process. Mr. Naraine estimates that using precast foundations will save one crew-day of labor—approximately \$1,700.

- **Precast foundations** – Precast foundations are beginning to see greater use in the residential market. They significantly decrease the time required to install the foundation. One system that has received considerable recent attention consists of panels of concrete studs with a wood nailing strip on their interior face (see Figure 26). Given that the panels are designed to accept conventional batt insulation and gypsum board, they lend themselves more readily to finishing by a homeowner or remodeler than traditional concrete or block walls. The cost of precast systems is significantly affected by transportation costs, thus precast foundations tend to be more economical in areas within 100 miles of the precast plant. Certain local circumstances can render precast foundations economical within 400-500 miles.

FRAMING

For decades now, HUD, NAHB, and others have promoted methods to reduce framing costs. Despite widespread recognition by the building codes, some methods have caught on while many others have not. Historically, the relatively inexpensive supply of lumber has been the primary barrier to wider use of these methods. With the unstable lumber prices of recent years, however, attitudes toward innovative framing methods are shifting.

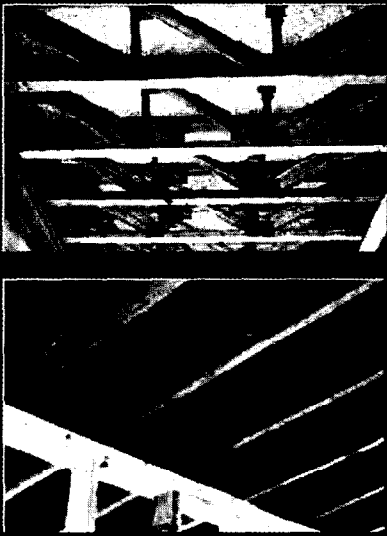

- **Open floor plans** – The use of open floor plans has a direct impact on framing costs by reducing the linear footage of partition walls. It also has indirect impacts on costs by reducing electrical costs, increases the flexibility of the space, and conveys the space of a larger home. On the other hand, the trend toward open floor plans has resulted in the demand for larger spans, which can increase the costs for dimensional lumber. Nonetheless, roof trusses, I-joists, and other innovations are making it easier to accommodate open floor plans, particularly in smaller and narrower homes.
- **Trusses and I-joists** – The advantages of engineered products such as parallel chord floor trusses and I-joists (see Figure 27) are related more to flexibility and long-term costs than to initial construction costs. For example, engineered products can add marketing advantages such as larger open spaces. Further, because the products are engineered, their stability and tolerances tend to be better than dimensional lumber. The result is often less waste and fewer rejected items than with dimensional lumber, which can translate into reduced labor and waste disposal costs.



Builder: The Bigelow Group
Palatine, IL

Jim Meigs, Vice
President

Homes: 900-1,750 square
feet, two-story, slab-
on-grade

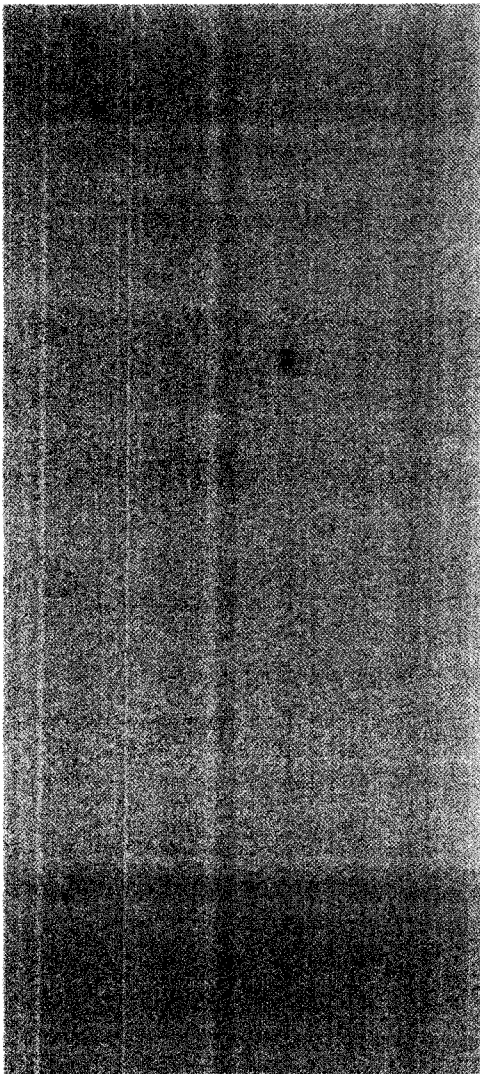

Profile: Optimum Value Engineering (OVE)
Savings: \$100 to \$800

“Engineering our floor system gave us a 24-inch floor joist spacing with dimensional lumber and eliminated customer complaints over floor bounce.”

Approach

The Bigelow Group takes full advantage of OVE framing, including 2x4 studs 24 inches on-center (o.c.), single top plates, and two-stud corners. When Bigelow changed floor joist spacing from 16 inches o.c., customers complained about excessive bounce. The firm examined costs for different floor joist spacing, including 19.2 inches o.c. The least expensive system called for joists at 24 inches o.c. and increasing the OSB subflooring thickness from 1/2 to 7/8 inch.

Results

OVE provided the lowest framing cost while maintaining high customer satisfaction. Using OVE for floor framing saves The Bigelow Group approximately \$100 per house compared to 16 o.c. framing and \$800 over engineered wood I-joists.

- **Optimum Value Engineering (OVE)** – OVE applies value engineering to reduce waste in structural design. One of OVE’s major premises is that building and room dimensions should be planned in sizes that are consistent with building material sizes, which typically means two- or four-foot modules. In roof truss applications, 24-inch spacing has already become the norm; and it is also finding its way into wall and floor framing. In fact, floors can be built on either 19.2- or 24-inch centers under the OVE approach and still meet the stiffness that codes require and consumers have come to expect. Other OVE applications call for the use of two-stud corners, nonstructural headers in nonbearing conditions, and in-line framing to eliminate the need for a double top plate (in fact, elimination of the double top plate is recommended in all nonbearing walls).

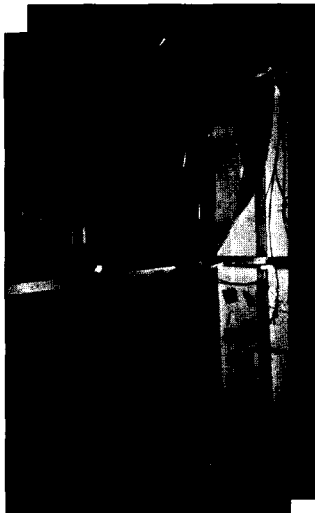

Builder: Southern General
Pembroke Pines, FL

Milton Bloom,
President

Homes: two-story, slab-on-
grade

Profile: Cold-Formed Steel Partitions
Savings: \$400 to \$500

“For us, there really is no other choice. Steel-framed interior walls provide a superior finished product.”

Approach

In the face of large fluctuations in the price of lumber, many builders have chosen to incorporate steel framing into the interior partition walls of their homes.

In addition to stable prices, steel studs provide dimensional stability and corrosion resistance. Many builders in Florida have already begun to use steel studs in nonload bearing applications, but steel-framed partition walls can be incorporated into most building systems, in all areas of the country.

Results

By incorporating steel-framed interior partition walls, Southern General Builders is saving approximately \$400-\$500 per house.

- **Cold-formed steel partitions** – For years, steel has enjoyed a substantial market share for interior partitions in many parts of the Southeast and Southwest. In this particular application, steel continues to be one of the most cost-effective alternatives to wood framing. Most building codes permit the use of steel partition walls, partially because of their wide use in light commercial buildings.



FINISHES AND MISCELLANEOUS

For the home buyer, the interior and exterior finishes are some of the most important considerations in a purchase decision. As the most visible items in a house, the finishes contribute significantly to the marketability of the home and represent a significant cost. Builders should selectively choose exterior and interior finishes. These materials should be considered in terms of details, selection of products, and application of the options approach discussed earlier in the *Marketing* section.

- **Trim and other details** – Interior trim can add appeal to a home, but it also adds to costs. One approach is to eliminate the trim around windows altogether and use drywall returns; another approach is to eliminate trim around closets openings. It is relatively easy to obtain a finished appearance without trim because door margins mask jambs and inside space.
- **Exterior details** – It is entirely possible to build an aesthetically pleasing home without complex trim details. The key is to make creative use of the standard elements (roof, windows, and doors) that must go into the house, and not to incorporate expensive additional details. For example, consider roof trusses make it easy to create an attractive roof line without roof returns and architectural trim. Windows and landscaping can also be placed strategically to add to the home's appeal. You can also consider eliminating exterior trim or shutters on the side and rear elevations. The home in Figure 28 utilizes modest variations in roof lines and marginal front details to effectively enhance curb appeal.
- **Miscellaneous** – The options approach can be applied to the finish phase of the home to identify less-than-essential items and to educate the homeowner on the impact of their cost. Items to consider include side lights (glazing) around entrance doors and in garage doors, doorbells and knockers, extra hose bibs and electrical outlets, fencing, overhead lights in rooms, fireplaces, and automatic garage door openers. In place of a raised deck, you might consider a simple set of steps up to grade level or possibly a grade-level patio.





Builder: Marlink Builders
Hudsonville, MI

Duane Marlink,
Owner

Homes: 816 square feet main
living level & 700
square feet future area
in lower level, poured
concrete basement
foundation

Profile: Simplified Interior & Exterior Details
Savings: \$2,750

“Simplifying the interior and exterior details of a home doesn’t have to hurt it’s appearance. In fact, I incorporated many of these techniques in my own home.”

Approach

Marlink Builders found that interior trim around windows and closets was of little importance to their typical buyer. Conventional wood windows and moldings are expensive and labor intensive to install. Instead, Marlink uses economical vinyl windows and has their drywall contractor finish the returns. This provides a clean, modern looking finish at substantially less cost.

Details on the exterior of the homes can also be reduced, without affecting their marketability. Marlink uses a conventional gable style roof. They found that eliminating complicated roof lines and valleys can substantially lower the cost of roof systems.

Results

By incorporating less expensive vinyl windows and simple details around windows and closets, Marlink saves approximately \$2,000 per house. Simplifying roofing systems and exterior details saves an additional \$750 per house.

It is important not to eliminate the traditional items which make the house more marketable—at least not without first considering the presentation of the total home. Avoid simply showing home buyers a picture of the home without certain details; show prospects the complete package with landscaping, roof line, and windows and doors all contributing to the appearance of the home.

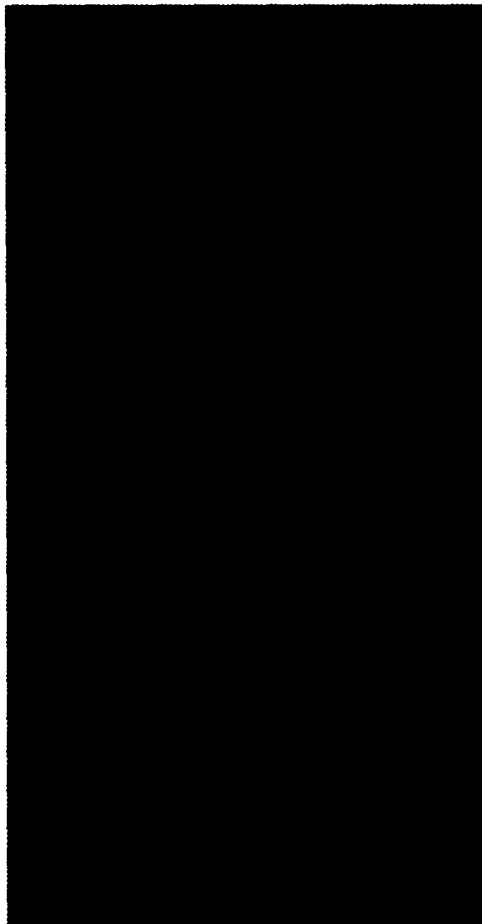

PURCHASING

Affordable builders can reduce material costs by purchasing many materials in volume or lots. For any component of your homes that is consistent or standard, there is an opportunity to receive volume discounts. While this technique may apply more to higher-volume builders, lower-volume builders can achieve some economy of scale if materials are standardized for affordable designs and storage or just-in-time delivery arrangements are available. Volume purchasing can save money on materials from lumber to lock sets to windows.

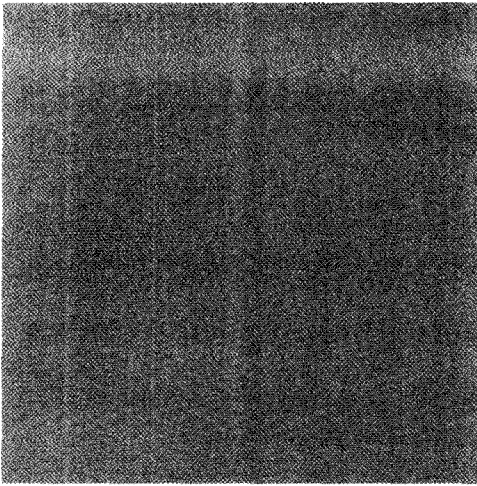

Builder: Eid-Co
Fargo, ND

Hap Hildebrand,
Production Manager

Homes: 1,400 square feet, bi-level homes

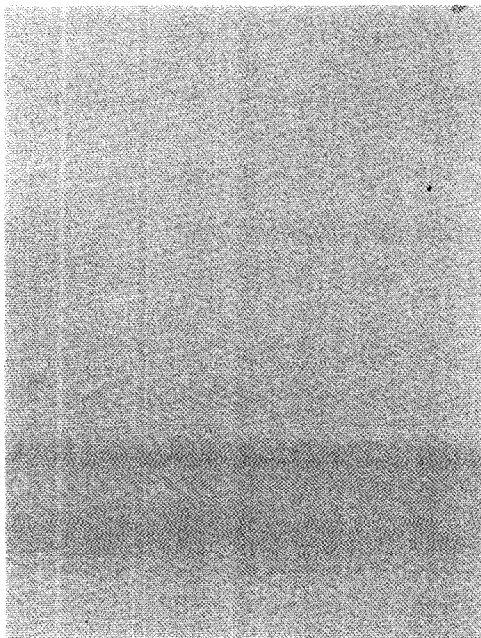

Profile: Purchasing
Savings: \$300

“Our company size allows us to purchase and inventory dimensional and sheet lumber, giving us constant prices throughout the year.”

Approach

Eid-Co purchases lumber on the wholesale commodity market. Eid-Co lumber is purchased in mixed-truck lots, consisting of both dimensional and sheet lumber. The lumber is broken down in Eid-Co’s yard, repackaged for the different framing requirements, and shipped out to each job site based on the specific requirements. Eid-Co also purchases finished goods such as appliances and plumbing fixtures in bulk.

Results

Eid-Co experiences a cost saving of approximately \$300 per house. Other benefits include consistent lumber quality and greater flexibility for the lead carpenters to plan their work.

USEFUL REFERENCES

NOTE: All of the resources detailed below were used in the development of the MADE-TO-LAST manual and are recommended for builders seeking follow-up information.

- *Cost-Effective Home Building: A Design and Construction Handbook*, NAHB Research Center, NAHB's Home Builder Press, 1994.
- *Challenge and Response - Volume I: Affordable Residential Land Development - A Guide for Local Government and Developers*, prepared by NAHB Research Center, Inc. for U.S. Department of Housing and Urban Development, July, 1987.
- *Challenge and Response - Volume II: Affordable Residential Construction - A Guide for Home Builders*, prepared by NAHB Research Center for US Department of Housing and Urban Development, July, 1987.
- *Innovative Rehabilitation Technologies: A State of the Art Review*, prepared by NAHB Research Center, Inc. and Building Technologies, Inc. for US Department of Housing and Urban Development, December, 1995.
- *Cost Saving Construction Opportunities and the HOME Program: Making the Most of HOME Funds*, prepared by NAHB Research Center, Inc. for US Department of Housing and Urban Development, December, 1994.
- *Design Guide for Frost-Protected Shallow Foundations*, NAHB Research Center, June, 1996.
- *Stemwall Foundations for Residential Construction*, NAHB Research Center, March, 1993.
- *Building With Alternatives to Lumber and Plywood*, NAHB Research Center, December, 1993.



MADE

to Last

DURABILITY FOR LONG LASTING AFFORDABLE HOMES

The initial cost of a home is one of two important measures of a home's affordability. The other important measure is the ability of the homeowner to operate and maintain the home economically. Monthly costs for insurance, principal and interest, energy, and repair/routine maintenance all play a part in determining the affordability of a home. One way to achieve significant reductions in operating costs is to design and build durability into the home.

The durability issues presented here have been compiled using:

- current builder survey results from NAHB, the NAHB Research Center, and the Canadian Mortgage and Housing Corporation;
- the results of a targeted survey of representative affordable housing builders;
- field engineer surveys from one of the largest home buyer's warranty companies; and
- input from the *MADE-TO-LAST* program's steering committee.

Each durability issue offers you an opportunity to either highlight your role in enhancing your homes' durability and decreasing maintenance requirements, or outline a homeowner role that capitalizes on your initial investment in durability and value.

The items discussed here do not represent the full range of durability issues associated with a home. For example, we do not recommend one particular grade of material or type of product over another. Material selection is a market decision best left to the builder and home buyer.

Quality materials don't necessarily have to substantially increase costs. The builder can advise the buyer in applying quality strategically. Comparisons between higher quality and increased cost differ with each material. The builder can work with the homeowner on where to spend more on higher quality materials so that durability and overall quality are maximized.

When considered in the context of the other sections of the *MADE-TO-LAST* manual, durability issues can be used to develop an overall approach to marketing the attractive, affordable, well-built entry-level home.



THE BUILDER'S ROLE

The following section identifies some of the major durability issues related to homes. Each issue is addressed by a conceptual or preventive approach or commonly accepted construction detail or other solution.

It is unlikely that all of the durability issues discussed here will apply to you. We suggest that you identify a core set of issues to be addressed in your homes. You can then develop promotional materials, plans, and specifications that relate to the selected items. Use these materials to promote the durability of your homes by showing prospective buyers how you address particular problems. These materials can also educate your potential buyers on how to operate and maintain a durable home. The link between your role and the homeowner's role is discussed at the end of this section and the accompanying appendix.

There are two major areas builders should look into when improving durability. The first is water. The majority of the durability issues discussed in this section deal with managing water outside and moisture inside the building envelope. Exterior durability issues with basements, siding, windows, and roofing usually deal with directing water flow. Interior issues typically deal with water in its vapor form as indoor moisture problems. As a builder you know when you think durability, you need to focus on water.

The second area builders should look into is on-site supervision. Many of the durability issues presented in this section can be traced back to the nature and details of the contractor's relationship with his own staff and his trade contractors. As a builder, you must ensure that your trade contractors are capable and conscientious. The lowest bids do not result in savings if they also result in lower quality and callbacks. Builders can look for contractors who have instituted a Quality Management system or they can suggest that trade contractors start such a program. In addition to hiring competent trade contractors, builders must provide adequate on-site supervision. The Useful References at the end of this section includes several sources for information on Quality Management.

Issue: Poor Drainage

Poor drainage is frequently the primary factor leading to water problems in basements. Particularly in expansive soils, poor drainage can also lead to structural damage. It can also cause nuisance flooding if the lot does

not drain properly. Some simple steps for reducing potential problems from poor drainage are presented in Figure 29 and include the following:

- Extend downspouts several feet from the foundation and use splash blocks to direct roof drainage away from the foundation. On lots with sufficient grades, the downspouts may also be routed into drain pipes placed under ground and exiting to daylight.
- Grade the area near the foundation to slope away from the house. Include an allowance for settling near the foundation. Frequently, uncompacted fill near the foundation will settle, leaving a trough that can funnel water directly back to the foundation wall.
- Grade the entire lot to move water effectively offsite.
- Use care in placing landscaping so it does not hinder drainage or cause ponding of water.
- Install a perimeter foundation drainage system routed to daylight.

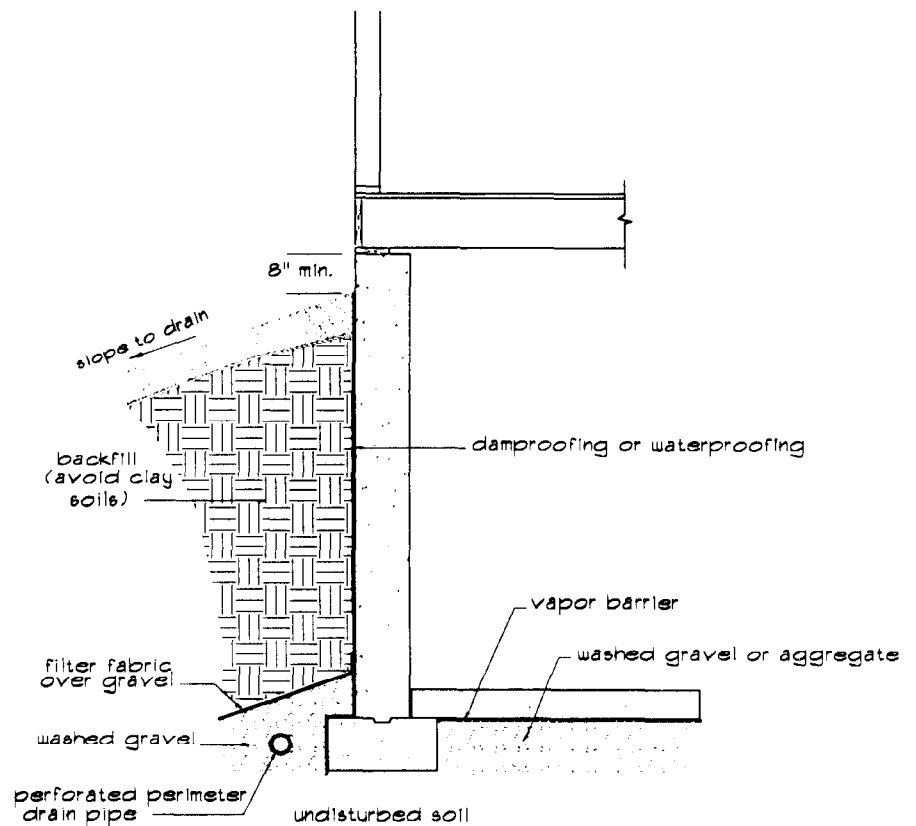

Figure 29 - Below-Grade Drainage Details

“By not appreciating the analogy between a basement and a well, people became alarmed when their basement drew water . . . People who lived in these circumstances became unhappy and they complained.”

*Richard L. Handy, from the book **The Day The House Fell**, ASCE Press, New York, 1995.*

Issue: Foundation Wall Cracks and Water Leakage

Even if they do not threaten the structural integrity of the wall, cracks in foundation walls tend to concern homeowners. More important, cracks can contribute to water leakage in basements. Cracking can result from incorrectly placed backfill that puts excessive forces on the wall, temperature changes and shrinkage, improper design of concrete mix, or inappropriate practices during casting or curing. The following practices can help reduce the potential for concrete cracking:

- Design the wall to account for pressures from soil conditions.
- Consider reinforcement for temperature and shrinkage crack control, even in a plain concrete wall.
- Use air-entrained concrete in moderate to severe climates.
- Request verification of the mix design from the plant, and do not add water at the site.
- Use well-drained backfill and a drainage system for subsurface water; grade the area to remove surface water.
- Use care in placing backfill. Keep heavy equipment away from the excavated area; do not use heavy equipment to compact the soil next to the wall. Protect against collapse or damage during construction by bracing the top of foundation walls or installing the floor joists before backfilling. As an alternative, design the walls as cantilevers if conditions make it impractical to put the floor deck on before backfilling.
- Maintain appropriate temperature for curing, usually above 40° F.

Water leakage is primarily an issue in basement homes, although it can be a problem in crawlspace homes as well. The most important items to address during construction to prevent foundation leaks are proper handling of roof runoff and other surface water, dampproofing or waterproofing, proper handling of below-grade openings, and subsurface drainage. Perhaps the most important of these is the handling of surface water from the roof or the area around the foundation as shown in Figure 30. Roof drainage and other surface water must be directed away from the foundation by using gutters and drainpipes, roof overhangs, and positive slope of the grade away from

the foundation. The positive slope away from the foundation is critical to any home. The need for overhangs and gutters should be based on cost and the demands of the local climate.

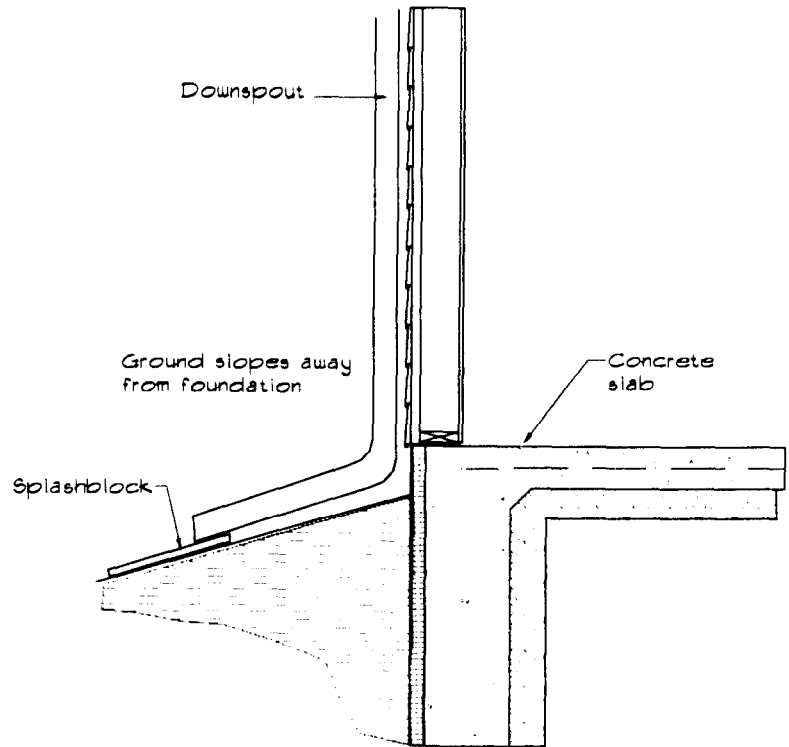

**Figure 30 - Above-Grade
Drainage Details**

Issue: Soil Swelling or Settlement

Soil problems are the leading cause of foundation failures, and foundation failures are the most expensive type of problem for builders to correct—often topping \$10,000 or more. Failures usually result from settlement of fill material or the expansion of certain types of clay soils. If you are building on fill, you should request a qualified specialist to specify the fill type. Both the type of fill and its placement should then be verified by observation or follow-up tests.

Characteristics of Bad Fill

- Topsoil
- Root Stumps
- Large Amounts of Clay
- Poor Compaction

If you are building on clays or otherwise expansive materials you should follow an engineered design or consider engaging the services of a design professional to ensure compliance with the design specifications. Other precautions used to reduce problems with soils include:

- Use of plumbing protection, especially where pipes pass through a foundation wall;
- Use of proper grading and drainage systems to remove water; and
- The removal of topsoil and other organics before casting a foundation.

Issue: Concrete Slab Cracking

Cracks in concrete slabs are one of the most common home buyer complaints. Figure 31 shows slab details that can minimize cracking. Proper preparation of the subgrade can help minimize cracking. First, you need to remove topsoil and other organics. Second, for areas that are overexcavated, you need to monitor the quality of the fill and see that the material is properly compacted to avoid settlement after the slab is cast. A four-inch nominal layer of aggregate or other well-drained material under the slab provides a firm base for supporting the slab. Aggregate can also provide a capillary break for moisture control.

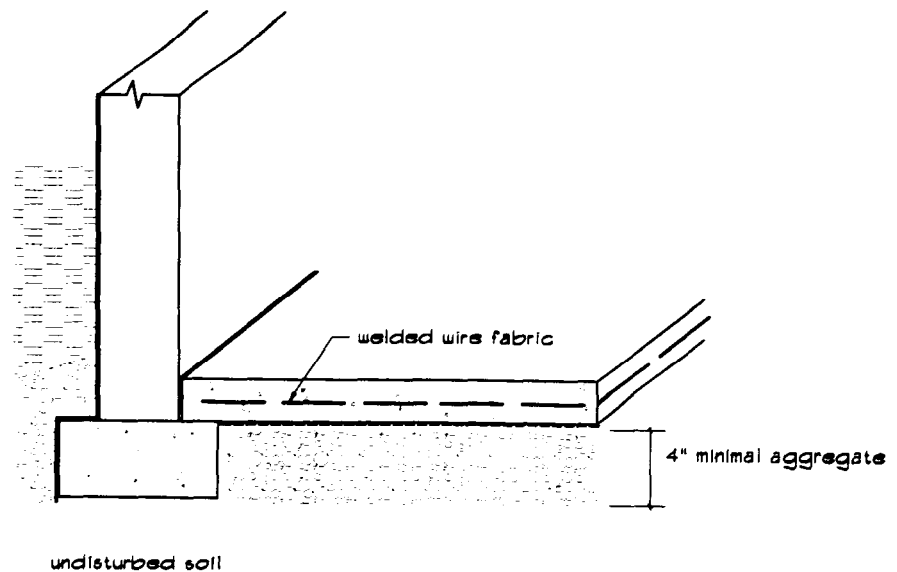
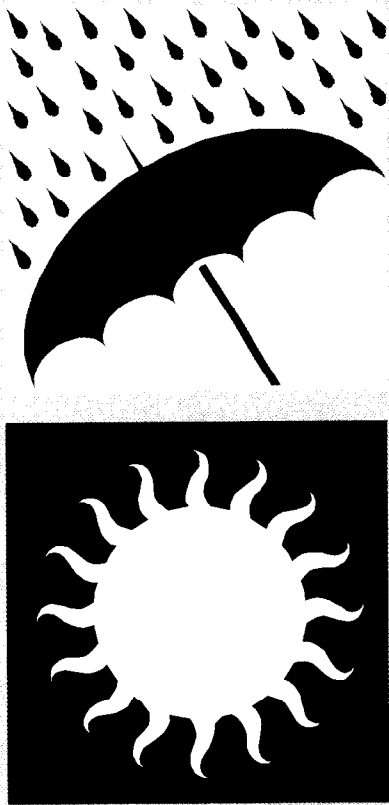

Figure 31 - Slab Details

Despite a firm subgrade and base, concrete by its very nature, cracks. However, it can be designed, placed, and cured to minimize the potential for cracking and to control crack width. Items to consider include the following:



- Use reinforcing steel, or welded wire mesh to resist temperature and shrinkage cracking; alternatively, use control joints to direct the location of cracking.
- Never cast a slab on frozen ground.
- Use air-entrained concrete where foundations are exposed to moderate or severe weather conditions.
- Request verification of the design mix from the plant; do not add water on site.
- Cast the concrete within 90 minutes of its leaving the plant.
- Cast the concrete continuously and deposit it as close as possible to its final destination. Do not allow the concrete to be “dropped” long distances during placement. The aggregate may become separated from the mix and weaken the concrete.
- Keep the temperature above 40° F.
- Cure the slab for two to three days after finishing by continuous wetting of the slab, covering the slab with a wet burlap or similar fabric, protecting the slab with curing paper or plastic sheathing, or applying a curing compound.

Issue: Warped or Delaminated Sheathing, Doors, and Other Products

Material warping results from the exposure of materials to moisture either during storage or construction. While doors are highly visible to the owner and most susceptible to warping, other less visible products throughout the house can be a source of long-term problems. For example, field-cut edges of sheathing products that are exposed to water can swell and create cosmetic and wear problems such as bumps in floor finishes. You can take steps to reduce the exposure of water-sensitive materials and enhance the durability of your homes. These steps include the following:

- Inspect your materials upon delivery for pre-existing damage.

- Create dry storage areas and make an effort to cover materials on site.
- Stage construction such that sensitive materials are covered or otherwise dried as soon as possible.

Issue: Roof, Wall, and Other Water Leaks

A leaky roof is another problem frequently identified by builders and homeowners. Improper flashing at valleys and other details, poor installation of underlayment or shingles, and improper installation of skylights and windows frequently lead to water leaks.

Don't leave construction details completely in the hands of your trade contractors. Provide them with the important details and specifications, such as those shown in Figure 32, that make your homes durable. Your construction should call for flashing, caulking, and drainage details around wall openings, at roof intersections, and for siding materials. Despite your best efforts, no construction provides perfect protection from water. Particularly in harsher climates, consider some redundant design features, including housewrap or similar material such as an underlayment behind siding, or furring behind siding to create a "breathable" water barrier. Roof overhangs provide added protection. Use simple roof lines and modest overhangs. These types of measures also provide energy efficiency benefits, which can be an additional selling point.

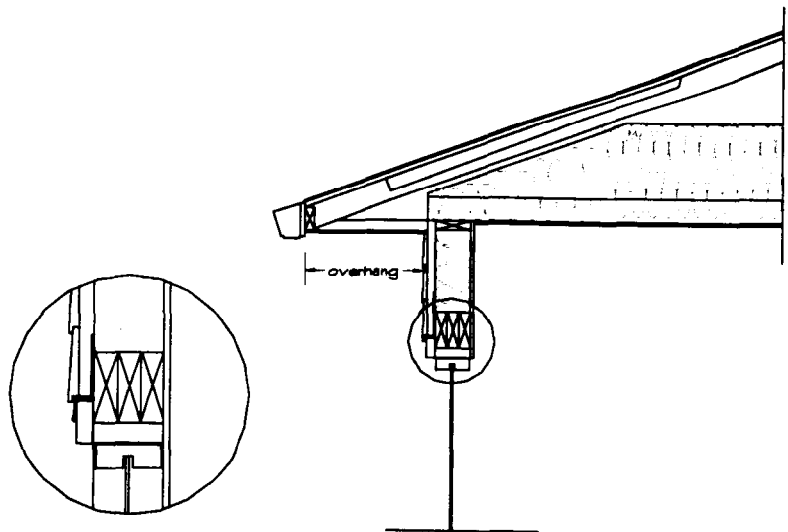

Figure 32 - Overhang and Window cap Flashing Detail

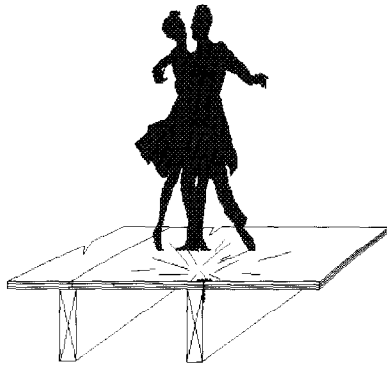

Figure 33 - Common Cause of Floor Squeaks

Issue: Noisy Floors

Noisy floors are one of the most common callback problems for builders. Floors, like other parts of a home, are subject to movement. The most typical noise is related to loose nails or other fasteners that squeak when a person walks across the floor. Sometimes, noise is the result of movement of the floor sheathing when attachment is insufficient (too few fasteners) or when the sheathing is not pulled tight to the joist. In other cases, fasteners that miss the floor joist below and end up alongside the joist (see Figure 33) create noise when the joist deflects and the nail rubs against it.

Although it is difficult to eliminate all noises, you can take steps to minimize them.

- Use only kiln-dried lumber, which is marked “KD.”
- Install the correct number, spacing, and type of fastener into the sheathing. Specify these items to your trade contractor.
- Suggest to your framers that they revert to the use of a chalk line to ensure that all fasteners hit the framing.
- Directly supervise (perhaps on an unannounced, random basis) contractors and/or inspect their work to ensure that they meet your specifications. Remember that it is much easier to fix a problem before drywall is installed, but you won’t find potential problems if you don’t inspect the work product.
- Consider the use of adhesives to help limit movement of the sheathing. Adhesives can stiffen the floor and reduce bounce. But be careful—an adhesive that sets up too soon can contribute to squeaks by preventing the sheathing from pulling tight to the floor joists.
- Some builders have used screws to reduce movement of the fasteners from the wood members, but such an approach should be weighed against the potential increase in costs.
- Finally, be prepared for floor noises despite your best efforts during construction. An internal inspection before your walkthrough with the buyer can identify problems, preventing a callback.

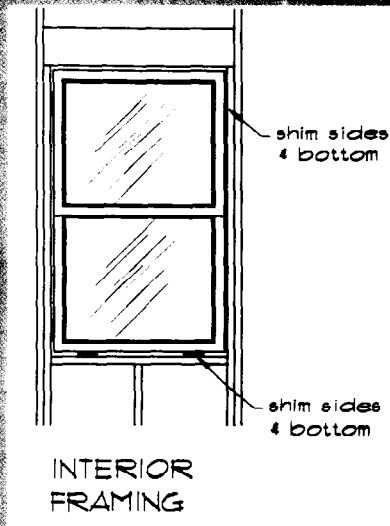

Issue: Inoperable Windows or Doors

Windows and doors can stick or be difficult to open and close for a number of reasons. Problems typically result from swelling of frames or bucks around openings, excessive deflection in headers, or, in extreme cases, settling or swelling of the soils surrounding the foundation.

One way to reduce header deflection is to size the headers with sufficient stiffness. It is important to recognize, however, that temporary deflection and even permanent deflection can still occur and possibly interfere with window operation. A common practice that contributes to inoperable windows is shimming between the window frame and the header. Leave this space open to allow for deflection of the header (see Figure 34).

To avoid swelling of materials and subsequent problems with the operation of doors and windows, you must prevent the entry of water by specifying proper drainage and flashing details. Figure 35 provides an illustration of one manufacturer's details for vinyl siding. It is very important to insure that the siding is installed according to the manufacturer's specifications. As with other areas of the home, make sure your trade contractors understand and follow the specifications that make your homes durable. Do not assume that the same details that work with one type of exterior finish will work with others or that all windows or doors are the same with respect to the frame's watertightness. Make sure you and your trades have accurate information from the start.

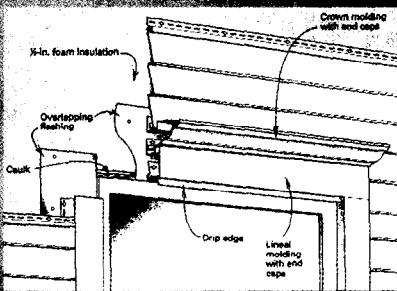

Issue: Drywall Finish

Cracks, visible seams, and nail pops are some of the most common interior finish complaints lodged by homeowners. Although you can't guarantee that a home will be immune from these problems, you can adopt some strategies to minimize their chances of occurring. One strategy calls for developing specifications for your drywall and framing contractors that clearly outlines your expectations. Another equally important strategy is follow-up supervision of contractors. As for construction, you might consider adopting the following:

- Use adhesives and/or screws as opposed to nails to reduce fastener pops.

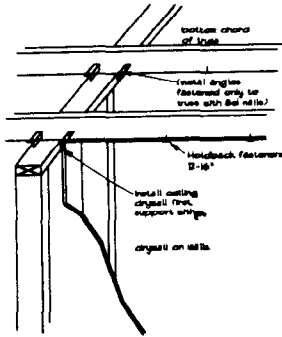
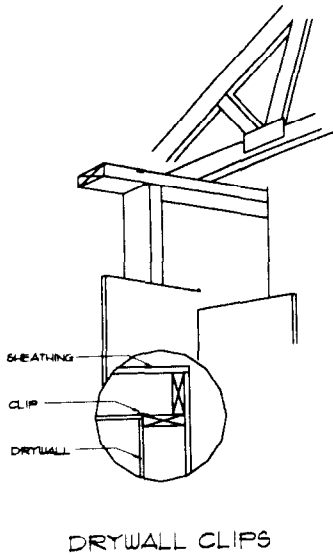

Figure 36 - Drywall Clips with Two-Corner Studs and Floating Ceiling/Interior Partition Joints

- Heat your homes and keep humidity low to limit chances that joint compound will either cure too quickly or slowly and cause seams to crack.
- Reduce shrinkage that causes nail pops and cracks by specifying only kiln-dried lumber.
- Hang drywall to minimize joints directly at the ends or over headers or other openings.
- Consider stiffer floor and ceiling framing to minimize deflection that can create cracks along seams.
- Use two-stud corners and drywall clips to minimize cracks at outside corners (see top drawing, Figure 36).
- When installing drywall on ceilings, float the ends of the sheets. This will avoid cracking if the trusses move (see bottom drawing, Figure 36).

Finally, the *MADE-TO-LAST* program cannot overstress the importance of finding a drywall contractor whom you can trust to do a good job. The lowest bid does not always result in the lowest cost, especially if you consider the cost of callbacks.

Issue: Buckled Siding

Vinyl and metal sidings expand and contract with temperature changes. To avoid unsightly buckling, contractors must follow the manufacturer's recommendations. Vinyl and similar siding materials should not be nailed or screwed tight to the studs or other building components. They should always be hung from the nail or screw to allow for the movement associated with expansion or contraction. You should be able to slide the siding slightly in each direction. In addition, it is important to leave a small amount of room at the end of sections that butt up to channels and corner trim.

A problem that commonly occurs with horizontal siding is buckling at rim joists as a consequence of shrinkage of larger lumber. To avoid potential callbacks, use engineered lumber for rim joists or check the siding manufacturer's recommended installation procedure.

Termite Control Techniques

- Install a termite shield between the foundation and sill plate
- Use only treated or naturally resistant wood when in contact with the ground
- Extend downspouts to keep moisture away from the foundation
- Consider physical barriers (e.g. sand or a metal termite shield)
- Keep landscaping from coming in contact with wall surfaces
- Do not store firewood or other woody materials near or against the home
- Maintain a clear 6" inspection zone at ground level on the foundation
- If a chemical termiticide barrier is used, select a firm that follows NPCA application rates and procedures

Issue: Termites

Throughout many areas of the country, termites present a significant durability problem. Most areas require some sort of pre-treatment for foundations. In addition to this initial protection, there are several other measures that home builders and homeowners can take to substantially lower the risk of termite infestation. Figure 37 presents several options.

Issue: Structural Damage From Wind and Earthquakes

Damage resulting from natural disasters is not always preventable. Potential for damage can be minimized with the durability recommendations discussed here. The use of durable construction techniques can help keep the structural components of a home intact and better able to resist the forces of wind, water, and earthquakes. A statistical survey of homes in the path of Hurricane Andrew showed that water damage to homes' contents had the greatest impact on overall damage. Most water damage was related to failed roof shingles and broken windows. Most of the structural damage was associated with poor quality fastening of roof sheathing. Figure 38 illustrates typical wind damage (top photo) and complete structural failure (bottom photo).

Hurricane Andrew was by all accounts an extreme event. Only the most costly building methods and materials could have withstood the storm's extraordinary force. In areas subject to such catastrophic forces, builders turn to alternative framing techniques which can be designed to more effectively resist such forces of nature. Regardless of the building method used, builders can follow some simple steps to get the most performance out of the materials and systems used to build homes in "high hazard" areas.

High Wind Areas

- Inspect roof sheathing attachment for proper nail patterns and nailing to gable-end trusses or rafters.
- Use connectors to reinforce all joints between roof, floor, and wall assemblies.
- Require six nails per asphalt roof shingle.



Figure 38 - Examples of Hurricane Damage

- Use structural sheathing on all walls to provide adequate bracing.
- Make structures less vulnerable to damage by using moderate roof slopes (5:12 to 7:12) and hip roof framing.

Plant trees as wind barriers, or use development practices that preserve trees and their significant benefits as barriers to high winds.

Earthquake-Prone Areas

- Use structural sheathing on all exterior walls (and even on some interior walls) for added support.
- Do not build on sites with “soft soils” or steep slopes.
- Avoid heavy roofing and floor covering materials such as tile and mortar.

Every builder and homeowner should remember that scientists do not fully understand catastrophic weather events and that many factors other than the type and quality of construction contribute to how a home will “weather” a storm. Some homes may suffer little damage while comparable homes next door may be completely destroyed. Our recommended practices will not ensure the survival of your home but they will enhance the chances of your home coming through a storm relatively intact. In high-hazard areas, the most effective and prudent route to durable construction might call for engaging the services of a knowledgeable design professional.

Given that connections are usually the culprit when it comes to wind and earthquake damage, inspections should focus on the integrity of various connections. An inspection checklist should require the following:

- Inspect sheathing fastening on the walls, floors, and roof for proper nail patterns, missed nails, and over-driven nails.
- Inspect for proper location and installation of required connectors (i.e., hurricane ties, and wall hold-downs).
- Check for proper roof sheathing attachment to the gable-end truss or rafter (i.e., six-inch nail spacing in lieu of 12-inch spacing).

As this list is not exhaustive, other items should be considered depending on the type of hazard—wind or earthquake.

Controlling Duct Leakage

●SEALING TECHNIQUES:

Standard: Aluminum tape

Better: Heavy-duty backed tape

Best: Mastic

- In tight areas seal ducts prior to installation
- Insulate ducts in unconditioned space
- Locate ducts in conditioned space as often as possible
- Conduct visual inspections of entire installation
- Follow ACCA Manual D duct specifications

Issue: Energy Efficiency/Indoor Moisture

Increased energy efficiency is often linked to housing affordability as a means of lowering the homeowner's monthly operating expenses. In addition, attention to energy-efficiency details can have a beneficial effect on the durability of several of a home's components. Correct insulating and ventilation not only increase energy efficiency, but can also reduce the occurrence of common indoor moisture problems.

- **Insulation** – Beyond the proper amount of insulation, proper installation of insulation can head off the potential for both thermal comfort problems and the build-up of condensation. A certification program for insulation installers has been developed to help eliminate callback problems—check with your local insulation distributor or supplier.
- **Attic ventilation** – Improper installation of attic insulation can block the air movement necessary for adequate roof ventilation and cause premature failure of the outer roof material and structural sheathing. More specifically, the air movement on the underside of the roof surface helps lower the roof temperature and prolong shingle life, prevent condensation, and improve drying if condensation occurs.
- **HVAC equipment sizing** – Many people have the mistaken impression that a larger furnace or air-conditioning unit is desirable. In fact, oversized equipment often leads to “duty cycles” where equipment turns on and off many times and thereby shortens its life and decreases energy efficiency. Even more serious problems occur with oversized air-conditioning equipment. Air conditioners are designed to cool the air and remove humidity or water. An oversized air conditioner cools the air but does not run long enough to effectively remove moisture, thus contributing to moisture problems such as the growth of mold or mildew.
- **Duct sealing** – The most efficient HVAC equipment and best insulating techniques can be wasted with a leaky duct system. Proper duct sealing techniques and insulation practices can substantially improve the efficiency and performance of any HVAC system. Figure 39 provides a list of proper duct practices.

- Air-sealing details** – Other energy-efficient construction details such as house wrap block the flow of air into the home and help prevent water from entering the structure. These barriers let the house “breathe” by allowing water vapor to pass through the wrap. Additional air-sealing details—sill plate sealers; caulking between adjacent framing members; sealing electrical, plumbing; and mechanical (i.e., ductwork) penetrations through the ceiling; and sealing around door or window rough openings—will translate into lower energy costs by eliminating paths through which air and moisture can enter the house. These detailed practices have a major effect on energy consumption and require the conscious efforts of both the builder and related trades. Figure 40 presents the typical sources of air leakage.

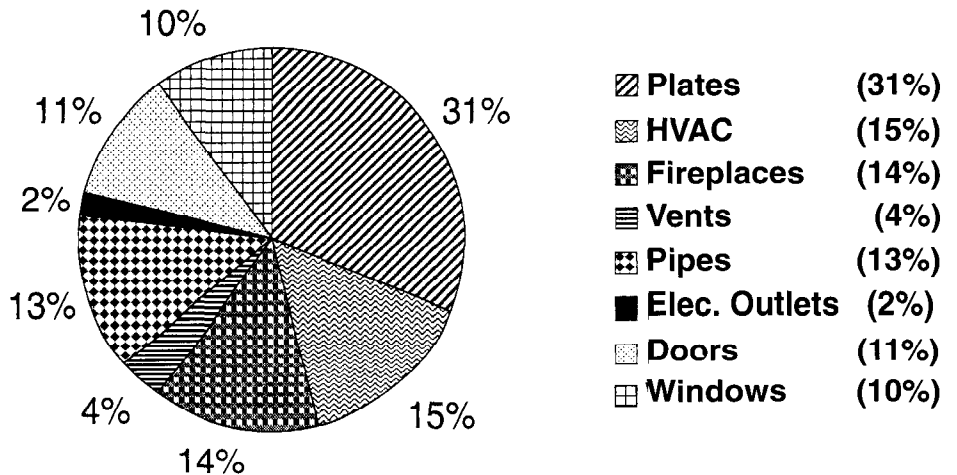

Figure 40 - Leading Causes of Air Leakage

(source: U.S. Department of Energy)

Builders must exercise care when incorporating energy-efficiency measures. Not all measures are cost effective. Particularly in smaller homes, you may need to strike a balance between the competing concerns of air infiltration and indoor air quality. Very tight homes may require additional ventilation, which can add to the cost of a home.

MADE

to Last

Homeowners play a central role in maintaining the builder's investment in durability. In any home, items need to be maintained properly if the home is to function at peak performance and products are to last for a reasonable period. If items are not properly maintained, homeowners may find themselves replacing components prematurely. In extreme cases, such as with expansive soils, an uninformed homeowner's actions can lead to serious structural problems. This section is intended to provide builders with recommendations they can give to homeowners to help maintain and enhance the durability of their new homes.

Some of the items identified for homeowner actions are closely linked to the durability issues already identified. It is important to make buyers aware of the relationship between the durability features you designed and built into their home and the role they need to play to maintain those features. For example, a buyer needs to understand that altering the grade around the foundation can reverse the steps you took to provide a dry basement.

Some of the items identified for homeowner action may reflect local or regional practices. In any case, you probably should develop your own information package for the homeowner. Resources are available to help you assemble a manual or set of guidelines for your buyers. A useful example of a homeowner's handbook is one developed by the Greater Atlanta Home Builders Association. The handbook is an important element in the HBA's certified professional builder program. We suggest that you contact your local Home Builders Association to see if similar resources exist in your area.

One way to demonstrate your commitment to durability is to prepare a homeowner's manual that deals specifically with maintenance. A homeowner's manual can:

- establish reasonable homeowner expectations for major products'/ systems' performance and average lifetime;
- recommend an inspection and/or replacement schedule for many major products/systems; and
- identify the most common short- and long-term durability problems along with causes and solutions.

The homeowner's manual can be used as a sale-closing marketing tool because of the distinction and value it gives your homes. The table on the following pages is one way to present some general maintenance information in an easy-to-understand and concise manner.

General Recommendations for the Homeowner's Manual

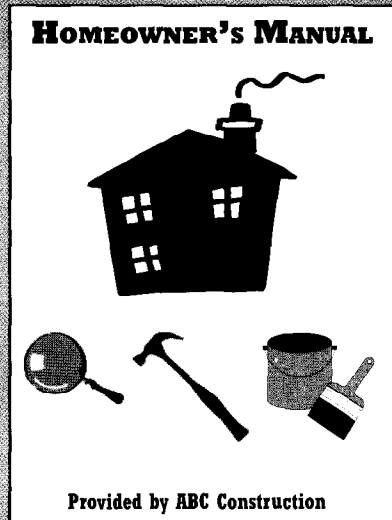

- Schedule a specific time with the buyer to review durability issues. The final walk-through presents an excellent opportunity.
- Compile and package information on appliances and other major equipment and systems. Homeowners will need to refer to the information periodically for operating instructions and warranty information. It is a good idea to compile the information in a single binder or folder with a consolidated maintenance schedule similar to that of an automobile.
- Recommend strongly that homeowners repair/replace damaged items as soon as possible after damage is detected. Further recommend the use of a professional for repairs and for additions and other modifications. Many codes require use of a professional for certain repairs and typically for any type of renovation.
- Provide guidance on the proper storage of problem materials that are excessively heavy, chemically reactive, or potential sources of moisture and pests.
- Recommend that residents check smoke detectors once a month and replace batteries at least every six months.

For further recommendations on developing a homeowner's manual, refer to Appendix C.



Building Components

Estimated Life Expectancy And Homeowner Maintenance Chart

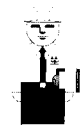
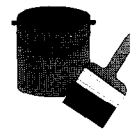

Seasonal Maintenance

Inspect

Clean

Paint/Seal

Professional

Building Component	Estimated Life* (years)	Homeowner Action		
Concrete/block foundation	100+			Check for cracks or surface deterioration. Consult a professional if you have any leaking or severe cracking. Check for termite tubes on foundation.
Exposed concrete slabs	25			Inspect for cracking. Seal to prevent water penetration
Siding (Lifespan depends on type)	10 - 100			Clean all types of siding. Paint or seal if you have wood siding (See exterior paints/stains.)
Drywall	30 - 70			Inspect, clean, and paint for aesthetic purposes
Roofing	15 - 30			Inspect for missing or deteriorated shingles. Clean to remove mold buildup.**
Gutters and Downspouts	30			Remove debris.
Insulation	100+			Inspect blown insulation in attic and check floor insulation (crawl space) to assure that it is in place.
Windows	20 - 50			Inspect and repair weather stripping. Inspect for broken seals in insulated windows. Clean exterior window frames.**
Exterior Doors	25 - 50			Clean and refinish when necessary. (See exterior paints/stains.)
Garage Doors	20 - 50			Clean garage door. Lubricate moving parts. Paint or seal as necessary.**
Exterior paints/stains	7 - 10			Clean and inspect. Repaint and caulk as needed.**
Wood floors	100+			Clean and wax.
Carpeting	11			Clean annually.



Seasonal Maintenance



Inspect



Clean

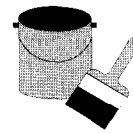

Paint/Seal



Professional

Building Component	Estimated Life* (years)		Homeowner Action
Sinks	5 - 30		Keep free of debris.
Toilets	50		Keep free of debris. Check tank seal for leaks.***
Faucets	13 - 20		Clean screen annually. Check for leaking seals.***
Water heater	14		Keep clean of household items. Annual professional maintenance.
Central air conditioning/heat pump (outside unit)	15		Keep free of plants and debris. Cover during winter months. Annual professional maintenance.
Furnace/heat pump (indoor unit)	18		Keep clear of household items. Annual professional maintenance. Inspect/replace filter according to manufacturer's recommendations.
Refrigerator	17		Keep interior condensation drains clean. Allow room behind and inside appliance for air circulation.
Dishwasher	10		Remove all food from dishes before placing in the washer. Clean the drain filter regularly.
Clothes Dryer	14		Clean lint filter regularly. Periodic professional cleanings will reduce risk of fire.
Clothes Washer	13		Keep lint trap free of debris. Clean tank occasionally.
Smoke Detector	12		Test and check batteries.
Wood Framing	100+		(See termite protection.)
Termite protection (chemical treatment)	5		Yearly inspection and re-treat as necessary.

*All numbers excerpted and condensed from: NAHB Life Expectancy Survey from "Housing, Facts, Figures and Trends" (1997)

** Use care if power washing. The high pressure water can cause more harm than help if not used cautiously.

*** Leaks account for 15-20% of total indoor water use.

USEFUL REFERENCES

- *Problem Areas for Builders*, prepared by Professional Builder & Remodeler magazine and NAHB Research Center, Inc., published by Cahners Publishing Co., April, 1992.
- *Builders Economic Council Survey – Special Questions (relating to Call-backs)*, NAHB, April, 1997.
- *Defect Prevention Research Project for Part 9 Houses, Final Report*, Canadian Mortgage and Housing Corporation, November, 1994 (rev.)
- *Construction Problems in Multi-Family Buildings*, Canadian Mortgage and Housing Corporation, March, 1991.
- “Writing an Owner’s Manual for a House”, *Fine Homebuilding*, John Abrams (author), March, 1998, pgs. 74-77.
- *Builder’s Guide: Mixed Climate – A systems approach to designing and building homes that are healthy, comfortable, durable, energy-efficient, and environmentally responsible*, Joseph Ltsiburek (author), prepared and copyrighted by Building Science Corporation and the Energy Efficient Building Association, 1997.
- *The Day the House Fell: Homeowner soil problems - from landslides to expansive clays and wet basements*, Richard L. Handy, Ph.D. (author), published by American Society of Civil Engineers Press, 1995.
- *Trade Contractor Quality Control*, NAHB Research Center, 1996.
- *Quality Management Best Practices for Home Builders*, NAHB Research Center, Home Builder Press, 1997.
- *A Builders Guide to Residential HVAC Systems*, NAHB Research Center, Home Builder Press, 1997.
- *Troubleshooting Guide to Residential Construction: The Diagnosis and Prevention of Common Building Problems*, A Journal of Light Construction Book, Steven Bliss (ed.), February, 1997.

The logo for 'MADE to Last' is positioned at the top of a vertical, textured grey bar on the left side of the page. The word 'MADE' is in a large, bold, black sans-serif font, with horizontal lines passing through it. Below it, the words 'to Last' are in a smaller, bold, black sans-serif font. The background of the logo area consists of horizontal lines that create a sense of depth and texture.

MADE

to Last

PUTTING IT ALL TOGETHER: The MADE-To-Last Demonstration Home

To provide a working example of MADE-TO-LAST principles, a site including four lots within the NAHB National Research Home Park located 30 miles east of Washington, DC, in Bowie, Maryland was selected. The National Research Home Park is part of a conventional residential development. The development plan allows flexibility in demonstrating innovative land development and housing technology.

Recent sales of townhouses and single-family detached homes in the surrounding community of Bowie, MD, place the average cost of the two home types at \$118,950 and \$188,200, respectively. The development includes deluxe townhouses, duplex homes and single family detached houses that are well above this average. The upscale character of some homes adjacent to the MADE-TO-LAST lots presents an extra challenge to the affordable demonstration home plans. The four-lot parcel selected for this exercise has lot sizes near the 8000 square foot minimum for the development. These lots represent a challenge similar to affordable infill with borders common to three different developments—a 30+ year old neighborhood of one-story single-family homes; the backyards of a recent moderate townhouse development; and, the backyards of deluxe duplexes and blank townhouse sidewalls in the recent upscale development. The site is also obstructed by an existing sewer line and split by a public pedestrian way that links the development to the older Bowie community (see attached drawings).

The following series of schematic designs and design development details for a single family detached house exemplify ideas presented in the MADE-TO-LAST builder's manual. A complete set of conceptual drawings is available through the NAHB Research Center. The plans include:

- 1.** existing development and lot layouts,
- 2.** proposed innovative lot layouts,
- 3.** basic floor plans (and optional layouts) for the demonstration MADE-TO-LAST home,
- 4.** sections and elevations for the demonstration MADE-TO-LAST home.

MADE-TO-LAST Features:

The demonstration home will contain the following MADE-TO-LAST features:

- reconfigured lot layouts
- straightforward, modular dimensions - 24'x40' rectangular footprint
- overall low square footage - *Total*: 960 sq.ft. without attic expansion
- strategic use of windows and standardization of window sizes
- full front porch to increase curb appeal, a sense of community, shading of the west elevation
- efficient framing techniques
- physical link of living/dining spaces with outdoor space
- simple, strategically selected and placed landscaping details
- *flexible* living/dining/kitchen area & flexible first floor bedroom (future living/office space)
- walk-in kitchen pantry
- L-shaped stair designed for ease of use for future attic expansion
- tight, well-insulated envelope to reduce monthly expenditures for energy
- steep roof slope (12:12) allowing for attic expansion using attic trusses
- straightforward extension of plumbing to potential second bathroom in attic
- *expandable* attic space 16'x40' (640 sq.ft.) with the additional south-facing dormer area 10'x12' (120 sq.ft.) for a useable attic—additional bedroom(s) and supplementary living space—of 760 sq.ft. *Expanded Total*: 1864 sq.ft.
- *expandable* outdoor space to the east off of the gable end of the house

ORIGINAL LOT CONFIGURATION

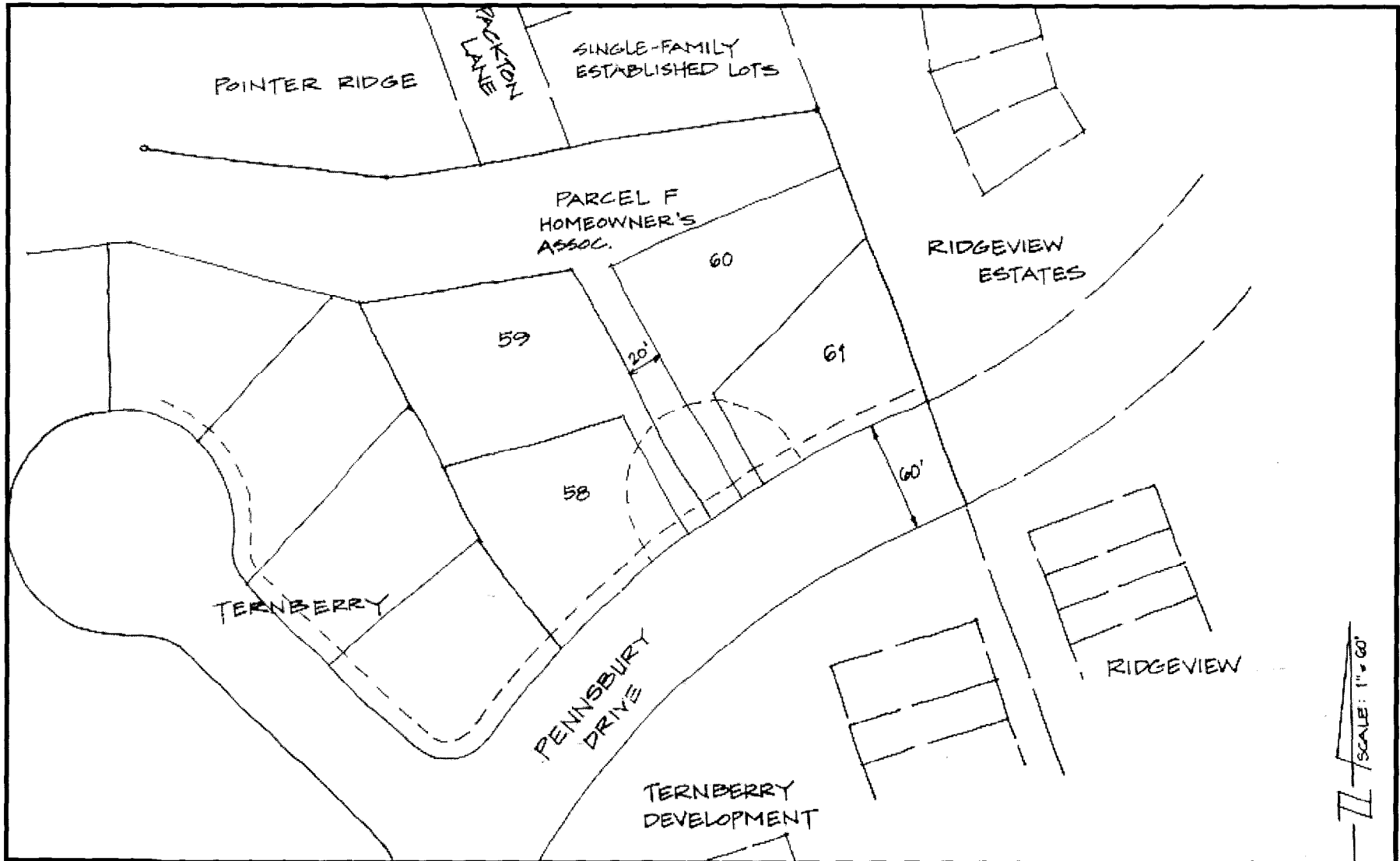

PROPOSED LOT CONFIGURATION

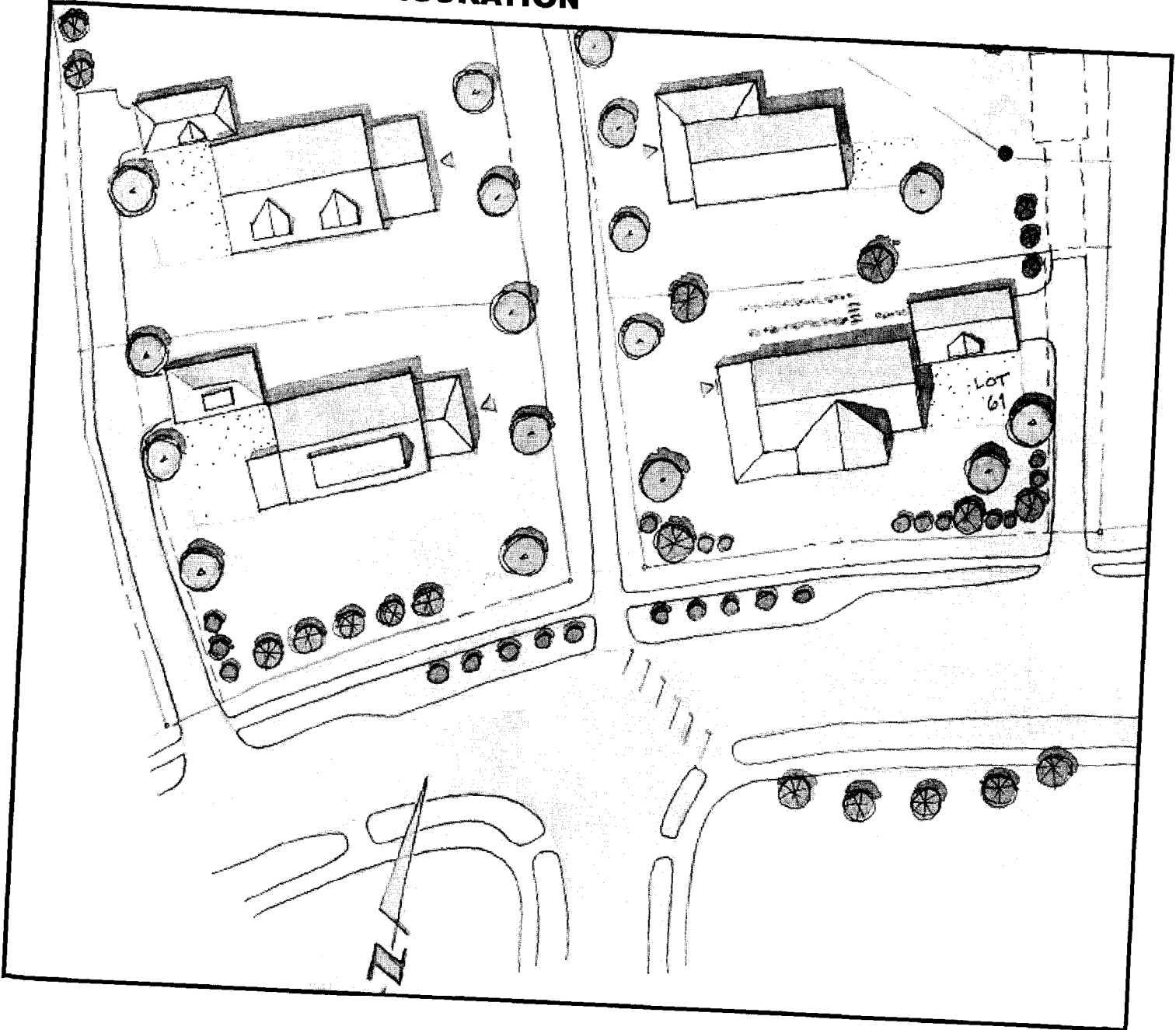

BASELINE ELEVATIONS

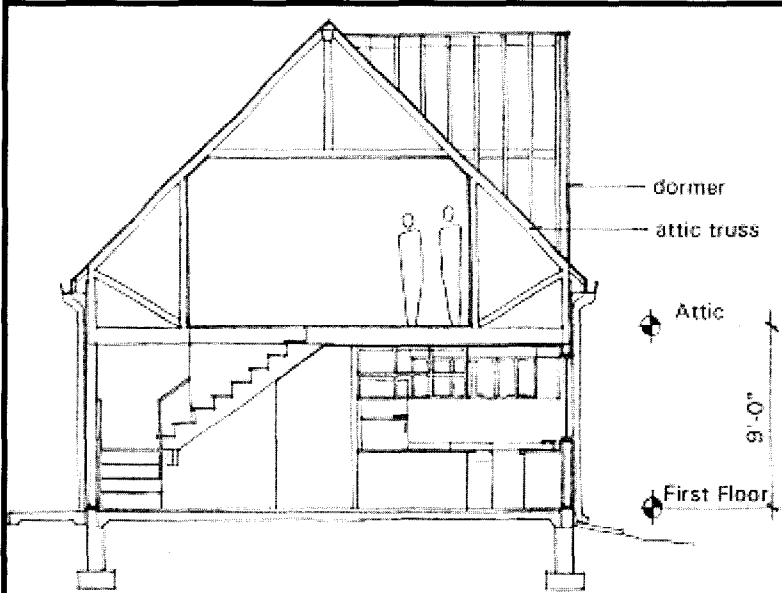

Section
Baseline House

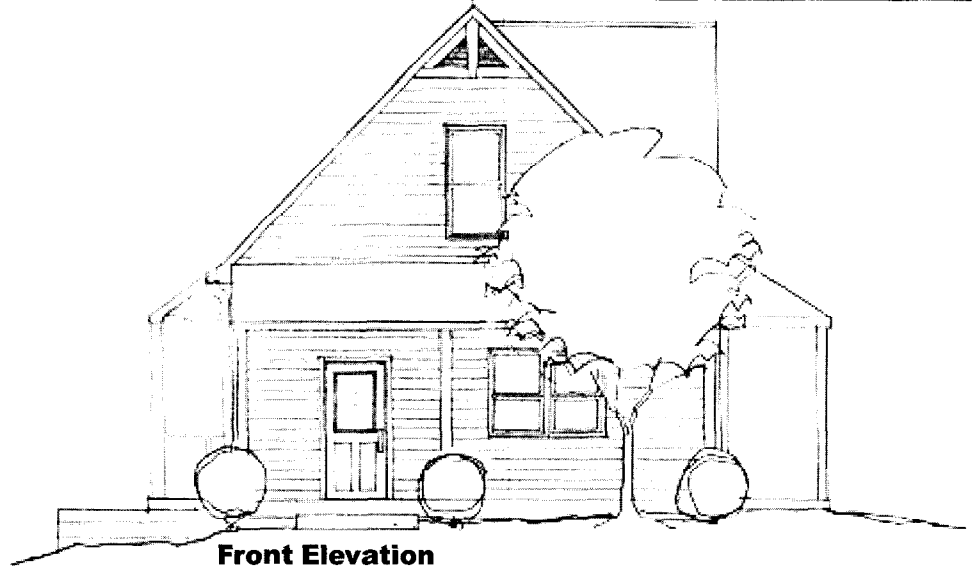

Front Elevation

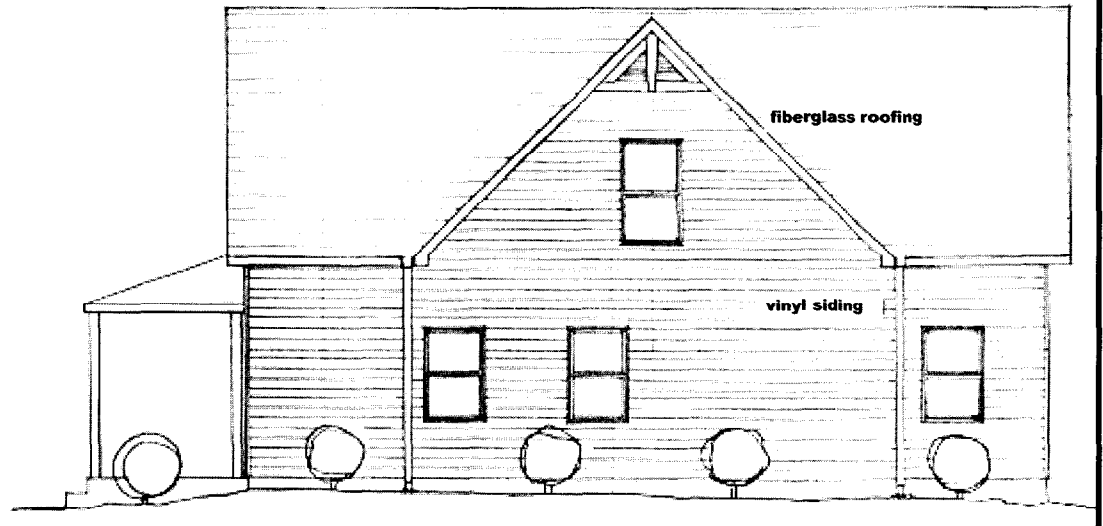

Side Elevation
Baseline House

BASELINE FLOOR PLAN

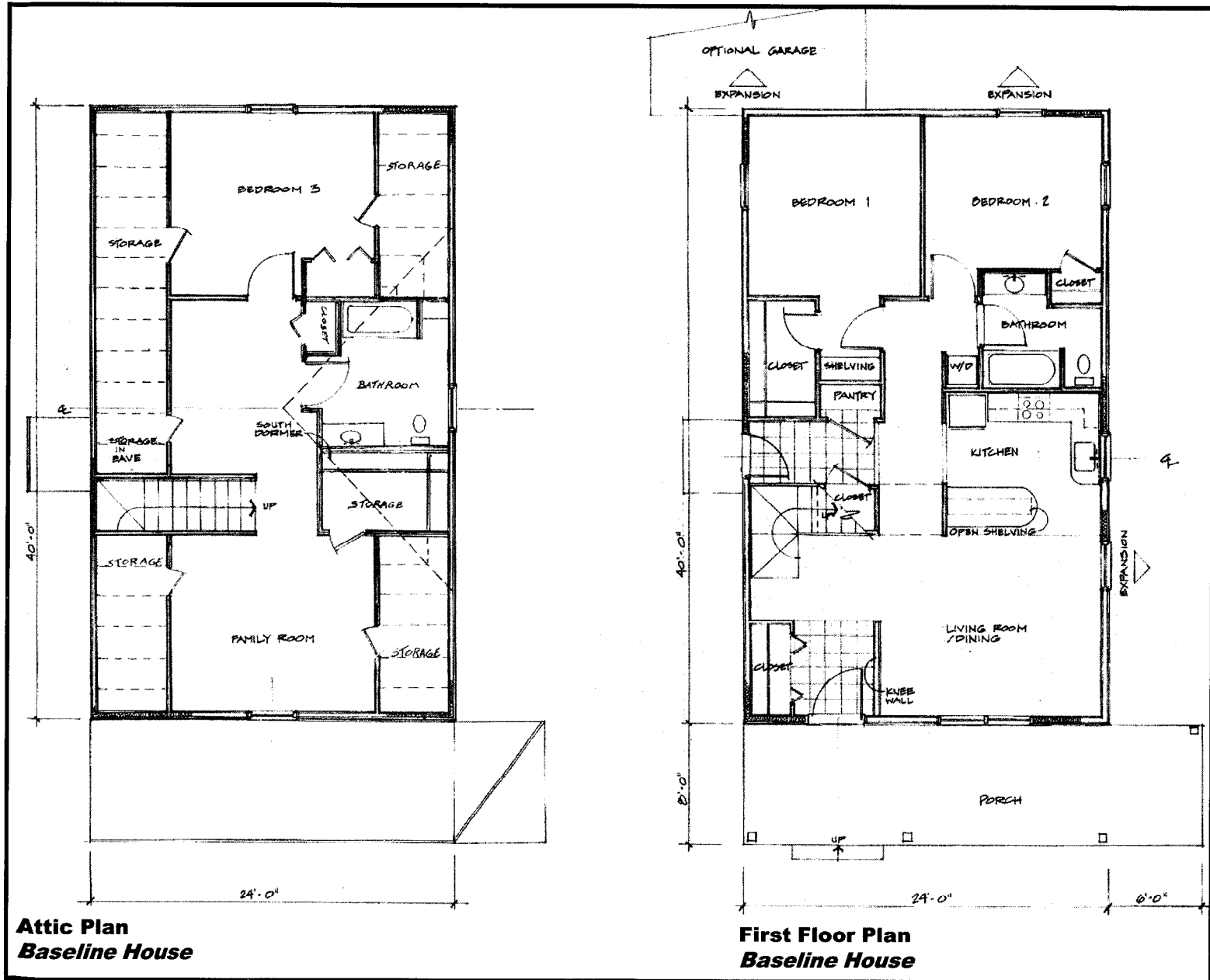

Attic Plan
Baseline House

First Floor Plan
Baseline House

OPTIONAL ELEVATIONS

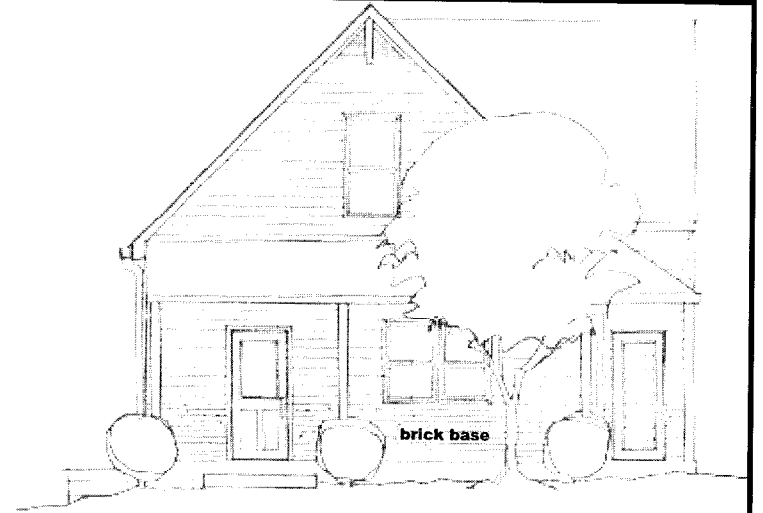

West Elevation

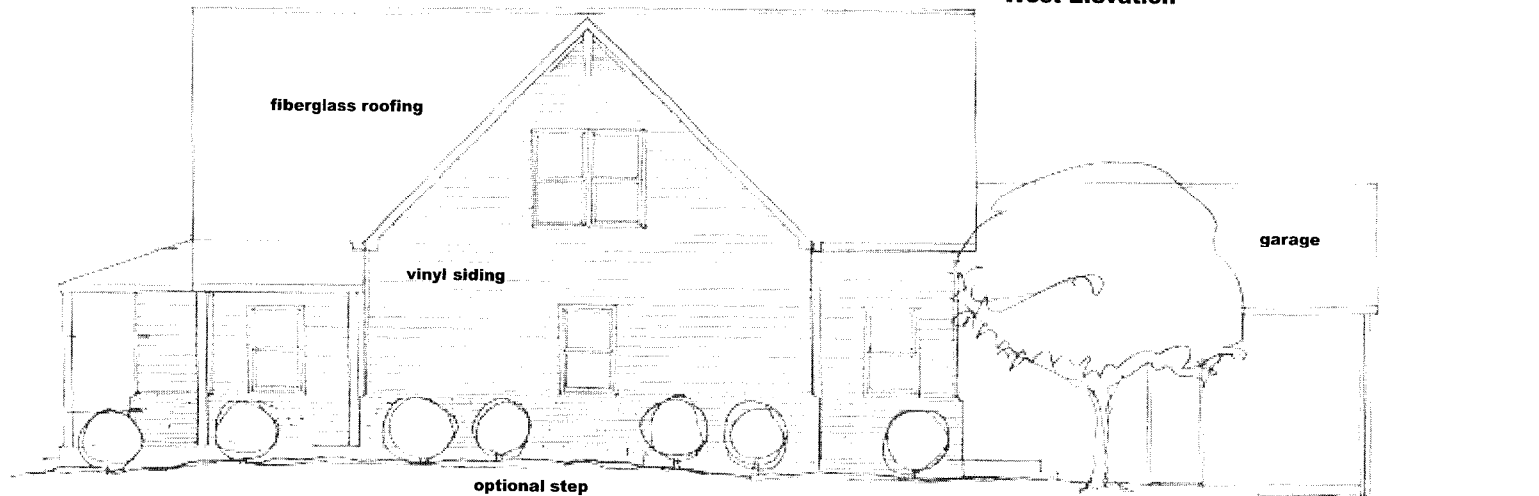

South Elevation
Lot 61 - Bowie, Maryland

OPTIONAL FLOOR PLAN

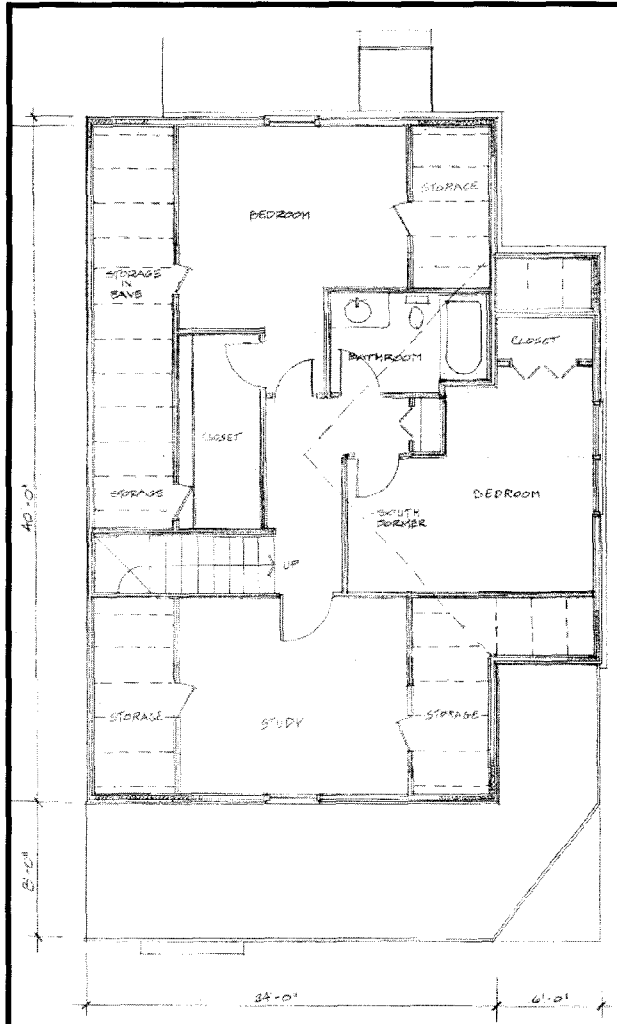

Attic Plan
Lot 61 - Bowie, Maryland

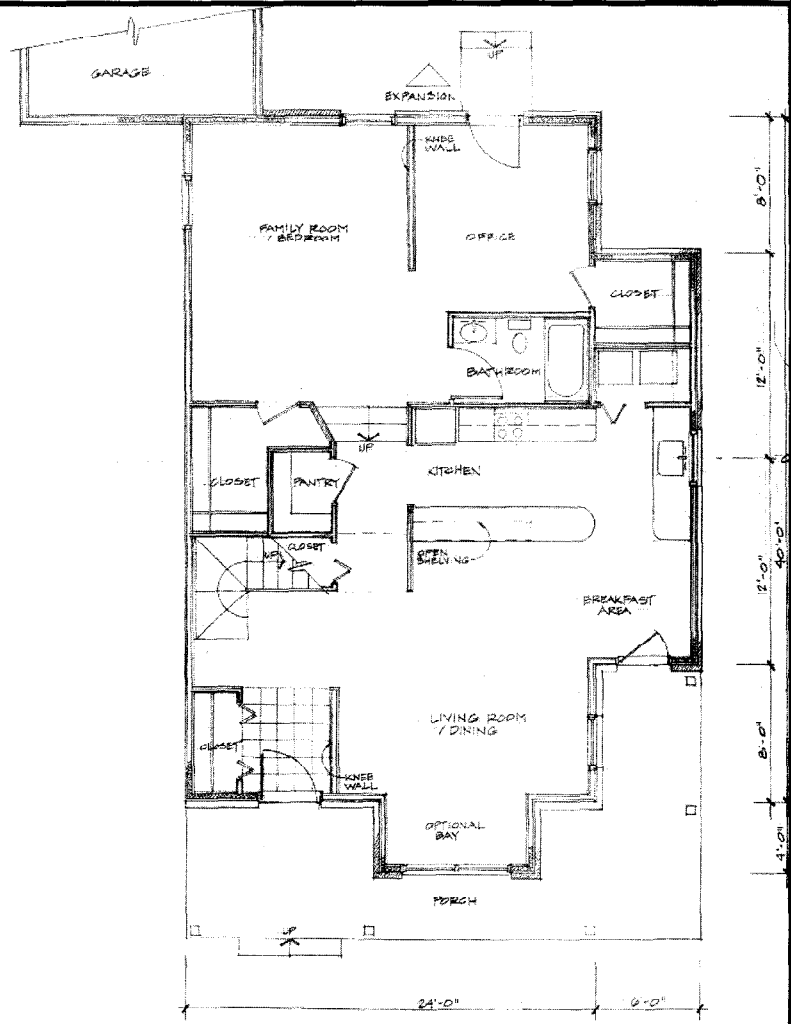

First Floor Plan
Lot 61 - Bowie, Maryland

APPENDIX A: EXAMPLE OF BUILDER INNOVATIVE FINANCING

BOB SCHMITT HOMES INC. THE BOB SCHMITT HOMES “PAY GROW” PLAN

The “Pay Grow” Contract was developed in 1975. Since then about 1,000 new homes have been sold under this plan.

Its original objective was to stimulate sales during the 1974-75 recession by reducing the down payment, eliminating buyer closing costs, a temporary price discount and payments of interest only during the first five years. Recovery of the discount and closing costs is described herein.

“Pay Grow” provides attractive options to buyers:

1. They may convert to fee ownership at any time by paying and financing the conversion price.
2. They may sell the property and realize profit over the conversion price.
3. They may turn the property back and recover the down payment (In the first three years there is a decreasing moderate charge for a turnback).

In the “Pay Grow” contract the legal title of the property is placed in trust. The buyer is the trust beneficiary and therefore the beneficial owner. This feature gives all parties the ultimate protection against liens, judgments, or inability to make payments. The legal title in trust cannot be directly assailed.

Beyond these primary features this contract has many other desirable aspects from the seller’s, lender’s and buyer’s points of view. Following are these points from the position of each.

Buyer Advantages:

1. As little as 9% down payment.
2. No closing costs.
3. Beginning low monthly payments due to temporary discount and interest only payments.
4. No risk to the buyer due to the turnback feature.
5. Permits buyer to purchase a home much sooner than usual and participate in its appreciation as well as having its use.
6. 100% of the buyer’s payments is income tax deductible during the first five years.
7. Permits buyer to receive credit for improvements of the property, thereby encouraging improvement.
8. Offers an important advantage to the short-term owner who must move often. Because of sales and transfer costs and short term limited appreciation, this buyer is often in a position to lose money and is therefore reluctant to buy.

Seller/Builder Advantages:

1. Increases his market beyond conventional ownership limitations.
2. Is its own "profit center."
3. Is a vehicle for a builder to hold on to his homes through several ownerships and thereby profit from the long range appreciation and inflation.
4. Is a tax shelter without appreciable reduction in cash flow.
5. Substantially reduces the cost of property ownership change because of no remortgage or title transfer costs beyond the first.
6. Provides a hedge for bad economic periods.
7. Provides a less costly and manageable means of interest subsidy than interest rate buy down programs.
8. Enables level production and sound growth.

Lender Advantages:

1. Foreclosure proof-loan. Because legal title is in trust, it is unassailable by either buyer or seller creditors.
2. More secure loan. The buyer and the builder are both obligated to make payments on the loan.
3. In case of payment difficulty with the buyer, the builder is on the spot to monitor and service the loan.
4. In case the buyer must be evicted for lack of payment (which can be done quickly), the builder has the means and motive to renovate, care for and resell the property.
5. With one original loan and closing, the property can pass through several ownerships without additional closing and remortgaging costs.
6. Interest rates can be adjusted to market on subsequent sales of each home.
7. Price can be adjusted to market at each subsequent transaction.
8. Builder has a substantial equity in each property thereby tending to assure his initial and continued concern with the quality of the house and the transaction.

APPENDIX B: KEY CONCEPTS FOR STREAMLINING LAND DEVELOPMENT

Builders and developers of all types of housing as well as potential homeowners are affected by the increasingly high costs of developing land for home construction. These costs stem from increasingly lengthy and complex approval procedures, resource protection standards, and fees assessed on development. The proportion of total costs that land development represents is even greater for more affordably priced housing.

Over the years numerous task forces and commissions have investigated how land development costs might be minimized by streamlining and better coordinating the approval process for new homes. Some of the reports that have resulted from these efforts are listed at the end of this appendix.

While every builder and developer would like to see a single model development ordinance that could be used in their municipality, there is simply no single approach or document that will work in every situation. A particular danger of model ordinances is that the temptation is great to borrow the model ordinance wholesale without modifying it to make it appropriate for the particular jurisdiction. At the same time, many of the studies and reports that have looked at streamlining the development approval process have suggested similar strategies. The list below can be used by builders and developers working to achieve more effective, efficient, and less costly approval processes in their own municipalities.

- 1. Central permit information desk/One-stop permitting:** All requirements and permits for land development should be initiated from a single central location.
- 2. Ordinance checklists and approval process flow charts:** Ordinances should spell out where to submit applications, which agency has the final approval authority, and what the steps are for the various types of applications.
- 3. Pre-application conferences:** Encouraging developers to meet informally with planning staff to present concepts for a project can help address issues and requirements before expensive technical and engineering work has been conducted and applications initiated.
- 4. Interdepartmental review committees with designated coordinator and simultaneous reviews:** A single point of contact and review coordinator, such as the Planning Director, can greatly help coordinate reviews by multiple agencies and work out discrepancies in the comments received from those agencies. Simultaneous reviews allows different steps in an application to be reviewed together as a package or at least at similar times, reducing the time involved in sequential reviews.
- 5. Create a hierarchy or rank projects:** Small and non-controversial projects can be “fast-tracked” by being handled as administrative rather than as legislative approvals (allowing the Planning Director to review and approve them) or by reducing the number of requirements that apply to those projects. In this way, the level of attention is commensurate with the level of impacts of the project, with valuable public and private resources devoted only to the review of projects that have a greater impact on the community.

6. **Specify time frames/limits for reviews, inspection of constructed improvements, and release of performance bonds or guarantees:** Ordinances should specify when decisions will be made, such as 30 or 45 days after a public hearing on the project. The ordinance can also state that if decisions by the relevant agency are not made within that time frame, the approval can be assumed to be granted. The terms and conditions for accepting improvements constructed and financed by the developer, who must often post financial guarantees that ensure their construction, should be clearly described. The time frame for release of the guarantee should also be stated.
7. **Minimize the need for multiple public hearings:** The public does not typically need two and three opportunities to comment on a proposed project. A single hearing held by the Planning Commission or equivalent body can provide public perspective that can be evaluated along with other relevant criteria in deciding whether to approve or deny an application.
8. **Update ordinances on a regular basis:** Many communities add new requirements to ordinances over the years without ever going back to evaluate whether these are consistent with existing requirements. Requirements should also be evaluated periodically to ensure they reflect current demographic needs as well as current development concerns and practices.
9. **Simplify and reduce the number of zoning districts:** Consolidation of zoning districts can build more flexibility into the development process and reduce the need for rezonings.
10. **Allow and encourage innovative techniques:** Techniques that encourage more efficient and desirable land development should be encouraged through efficient approval procedures rather than subjected to lengthier special reviews. Cluster development and planned unit development should be allowed as conditional uses or as overlays to existing zoning districts rather than handled as rezonings. Small lot solutions and density bonuses are other options that should be considered.

USEFUL REFERENCES:

Streamlining Local Regulations: A Handbook for Reducing Housing/Development Costs. International City Management Association (ICMA), Washington, DC. Management Services Special Report, May, 1983, No.11. Report prepared by Stuart S. Hershey and Carolyn Garmise.

Affordable Housing: How Local Regulatory Improvements Can Help. US Department of housing and Urban Development, Washington, DC, US Government Printing Office, 1982.

Streamlining Your Local Development Process. National League of Cities, Washington, DC, Technical Bulletin No. 10, 1981.

Streamlining Land Use Regulation—A Guidebook for Local Governments. American Planning Association (APA) with the Urban Land Institute. Prepared for the US Department of Housing and Urban Development, US Government Printing Office, November, 1980.

The Subdivision and Site Plan Handbook, David Listokin and Carole Walker, 1989, Rutgers, The State University of New Jersey: Center for Urban Policy Research.

Removing Regulatory Barriers to Affordable Housing: How State and Localities Are Moving Ahead. US Department of Housing and Urban Development: Office of Policy Development and Research, copies available from: Regulatory Reform for Affordable Housing Information Center, PO Box 6091, Rockville, MD 20850.

APPENDIX C: SPECIFIC RECOMMENDATIONS FOR THE HOMEOWNER'S MANUAL

Preventing/Dealing with Water Problems

Water problems are most often related to leaks in the roof, at wall openings, and in basements. Even in a properly designed and built home, leaks can occur if surface water collects or is not allowed to drain away from the home. Specific actions required of the homeowner include the following:

- Keep gutters clean.
- Keep the grade intact around foundations and do not place vegetation such that it hinders the flow of surface water away from the foundation.
- Apply new caulk/sealant at windows and other openings as directed in manufacturer's recommendations, making sure the material is appropriate for the application.
- Repair damaged shingles, siding, and trim as soon as damage is evident.
- Re-roof at recommended intervals or when shingles appear worn.
- Keep sumps and drain openings operating and clear of obstructions.
- Repair plumbing leaks as soon as they are detected.
- Avoid excessive watering of lawns and plants, especially near the foundation and particularly if the home is sited on expansive soils.

Moisture

One of the most common issues related to durability is excessive moisture in baths and kitchens. Excessive moisture can lead to mold, drywall cracks, swelling of materials, and poor indoor air quality. Some recommendations for consideration follow:

- Make use of operable windows or use fans, especially during cooking, showering, and bathing to remove moisture.
- Recaulk annually around counters, plumbing fixtures, and others areas where water can penetrate.
- Always vent the clothes dryer to the outdoors. Avoid drying more than incidental clothing or other items inside the home.

Mechanical Equipment, Plumbing Fixtures, And Insulation

The life expectancy of water heaters, pumps, heating and cooling systems, and other properly installed mechanical equipment depends almost entirely on the user. The same can be said for plumbing fixtures, although the quality of water can influence the life of plumbing products. The following recommendations apply:

- Keep vents clear of obstructions.
- Replace filters on air handlers.
- Check insulation in attics, especially around vents where some insulation products may become dislodged; replace or redistribute insulation as needed.
- Conduct inspections as recommended by the manufacturer; consider a service contract on mechanical equipment.
- Operate equipment only in accordance with the operating instructions.
- Keep outdoor mechanical equipment clear of snow, ice, plants, and other obstructions.
- Clean plumbing fixtures with cleaners recommended by the manufacturer.
- Re-caulk around plumbing fixtures annually or at the first sign of deterioration.
- Do not flush items such as diapers, dental floss, and other goods inappropriate for disposal in toilets; this recommendation is even more important in an era of water-conserving toilets.
- If water quality is poor, consider a water treatment system to extend the life of dishwashers, washing machines, and faucets.
- Follow the recommendations for weatherstripping (below) for windows and doors.

Windows And Doors

Windows and doors can affect durability in two ways. First, they can fail to operate properly causing inconvenience and possibly a safety hazard. Second, they can significantly affect a home's energy efficiency. The following recommendations can help ensure the durability of windows and doors:

- Check weatherstripping at least annually, replace any weatherstripping that is worn or missing.
- Repaint or stain doors, windows, and associated trim as recommended by the manufacturer.
- Lubricate door locks with appropriate lubricant (not oil).
- Check and tighten nuts and bolts on garage doors.
- Lubricate garage door tracks, rollers, etc.
- Keep tracks of sliders/bi-fold doors free of dirt.

How To Renovate or Add-on

Whether a renovation or addition is undertaken by the homeowner or a licensed professional, the following recommendations can help protect the initial investment in the home:

- Maintain grading and ground drainage.
- Emphasize the importance of flashing and sealing details on new roof lines, windows, doors, and add-on decks (particularly if intersecting with the existing structure).
- Emphasize the importance of maintaining existing structural loading and design as new loads are introduced.
- Encourage homeowner to maintain the energy-efficiency and durability standards you established for their home.
- Always use a professional if you are inexperienced with repairs or modifications to your home. In many areas, local laws require minimum qualifications for persons performing certain types of work on a home.
- Ensure that modifications comply with the appropriate building code requirements and are inspected as required by the local code authority.

Storage

Improper storage can result in cosmetic or structural damage and can even present a fire or health hazard. Recommendations for appropriate storage follow:

- Do not use a trussed attic for storage unless it is designed for heavy storage.
- Do not overload the home; floor joists are not typically designed to handle heavy storage. Even the deflection from a waterbed can cause drywall cracks and other problems on a lower level.

Miscellaneous Exterior

The exterior of a home is frequently exposed to conditions more severe than the interior, including rain, snow, ice, wind, and exposure to the sun. Recommendations to extend durability of outdoor items include the following:

- Apply a sealant to outdoor decks four to six months after construction and thereafter annually.
- Inspect painted surfaces annually and repaint as needed.
- Keep children's pools and hot tubs off decks unless the loads are accounted for in the design.
- Remove snow and ice from exterior concrete as soon as possible; avoid using harsh chemicals on concrete.

- Keep landscaping trimmed or otherwise maintained at proper heights to ensure safety and to allow adequate natural light into windows. Mulch or new plantings should not impede the flow of water away from the foundation.
- Arrange for an annual maintenance contract with an exterminator for termites in high-risk areas.
- Keep crawlspace, dryer, stove, and other vents clear of obstructions.
- Clean siding in accordance with manufacturer's instructions.

Electrical

Although most electrical work in a home lasts for the life of the structure, the homeowner can take some actions to improve energy efficiency and maintain a safe home. Recommendations include the following:

- Keep landscaping from growing near overhead wires. Call your utility company to trim branches that encroach on the wires.
- Have the utility company locate below grade electric lines before you dig!
- Arrange for a professional to add new appliances or lighting to avoid overloading circuits.
- Test GFI breakers once a month.
- Use light bulbs that are approved for a given light fixture.

Appliances

Except for the matter of proper installation, the life expectancy of appliances is almost entirely dependent on the user. Thus, you must provide proper documentation for each appliance with respect to maintenance schedules, warranties, and operating instructions. The manual can include the following recommendations:

- Use and clean appliances only as directed by manufacturer.
- Maintain or inspect appliances on a regular basis. Consider purchasing a service plan for your appliances so that the responsibility for scheduled maintenance is transferred to a third party.
- Rely on a qualified professional to make repairs as soon as problems are detected.
- Clean dust from grilles on refrigerators and dryer vents regularly.

Floor and Other Finishes

Keeping floor surfaces clean and/or painted is one of the most important factors associated with the durability of finish surfaces. Floors, countertops, and other surfaces should be cleaned regularly to prevent build-up of dirt, oils, and other substances. Always use recommended cleaners, some types of cleaners can degrade finishes. Other recommendations to consider include the following:

- Follow cleaning, waxing, and other manufacturer's instructions, if required for a particular finish.
- Clean spills immediately.
- Vacuum carpets on a regular basis and arrange annually for professional cleaning and treatment for stain resistance.
- Arrange for the repair or replacement of damaged surfaces as soon as damage is detected.

**U.S. Department of Housing and Urban Development
HUD USER
P.O. Box 6091
Rockville, MD 20849**

FIRST-CLASS MAIL
POSTAGE & FEES PAID
HUD
Permit No. G-795

**Official Business
Penalty for Private Use \$300**

February 1999

