



NBS TECHNICAL NOTE **979**

ORIGINAL

U.S. DEPARTMENT OF COMMERCE / National Bureau of Standards

# Lead Paint Abatement Costs: Some Technical and Theoretical Considerations

## NATIONAL BUREAU OF STANDARDS

The National Bureau of Standards<sup>1</sup> was established by an act of Congress March 3, 1901. The Bureau's overall goal is to strengthen and advance the Nation's science and technology and facilitate their effective application for public benefit. To this end, the Bureau conducts research and provides: (1) a basis for the Nation's physical measurement system, (2) scientific and technological services for industry and government, (3) a technical basis for equity in trade, and (4) technical services to promote public safety. The Bureau's technical work is performed by the National Measurement Laboratory, the National Engineering Laboratory, and the Institute for Computer Sciences and Technology.

**THE NATIONAL MEASUREMENT LABORATORY** provides the national system of physical and chemical and materials measurement; coordinates the system with measurement systems of other nations and furnishes essential services leading to accurate and uniform physical and chemical measurement throughout the Nation's scientific community, industry, and commerce; conducts materials research leading to improved methods of measurement, standards, and data on the properties of materials needed by industry, commerce, educational institutions, and Government; provides advisory and research services to other Government Agencies; develops, produces, and distributes Standard Reference Materials; and provides calibration services. The Laboratory consists of the following centers:

Absolute Physical Quantities<sup>2</sup> — Radiation Research — Thermodynamics and Molecular Science — Analytical Chemistry — Materials Science.

**THE NATIONAL ENGINEERING LABORATORY** provides technology and technical services to users in the public and private sectors to address national needs and to solve national problems in the public interest; conducts research in engineering and applied science in support of objectives in these efforts; builds and maintains competence in the necessary disciplines required to carry out this research and technical service; develops engineering data and measurement capabilities; provides engineering measurement traceability services; develops test methods and proposes engineering standards and code changes; develops and proposes new engineering practices; and develops and improves mechanisms to transfer results of its research to the ultimate user. The Laboratory consists of the following centers:

Applied Mathematics — Electronics and Electrical Engineering<sup>2</sup> — Mechanical Engineering and Process Technology<sup>2</sup> — Building Technology — Fire Research — Consumer Product Technology — Field Methods.

**THE INSTITUTE FOR COMPUTER SCIENCES AND TECHNOLOGY** conducts research and provides scientific and technical services to aid Federal Agencies in the selection, acquisition, application, and use of computer technology to improve effectiveness and economy in Government operations in accordance with Public Law 89-306 (40 U.S.C. 759), relevant Executive Orders, and other directives; carries out this mission by managing the Federal Information Processing Standards Program, developing Federal ADP standards guidelines, and managing Federal participation in ADP voluntary standardization activities; provides scientific and technological advisory services and assistance to Federal Agencies; and provides the technical foundation for computer-related policies of the Federal Government. The Institute consists of the following divisions:

Systems and Software — Computer Systems Engineering — Information Technology.

<sup>1</sup>Headquarters and Laboratories at Gaithersburg, Maryland, unless otherwise noted; mailing address Washington, D.C. 20234.

<sup>2</sup>Some divisions within the center are located at Boulder, Colorado, 80303.

The National Bureau of Standards was reorganized, effective April 9, 1978.

# Lead Paint Abatement Costs: Some Technical and Theoretical Considerations

---

Robert E. Chapman  
Joseph G. Kowalski

FILE COPY

Building Economics and Regulatory  
Technology Division  
Center for Building Technology  
National Engineering Laboratory  
National Bureau of Standards  
Washington, D.C. 20234

Sponsored by the:  
Office of Policy Development and Research  
Department of Housing and Urban Development  
Washington, D.C. 20410



---

U.S. DEPARTMENT OF COMMERCE, Juanita M. Kreps, Secretary

Jordan J. Baruch, Assistant Secretary for Science and Technology

NATIONAL BUREAU OF STANDARDS, Ernest Ambler, Director

Issued February 1979

For sale by the Superintendent of Documents, U.S. Government Printing Office, Washington, D.C. 20402  
Stock No. 003-003-02022-2 Price \$3.25

(Add 25 percent additional for other than U.S. mailing).

**National Bureau of Standards Technical Note 979**

Nat. Bur. Stand. (U.S.), Tech. Note 979, 153 pages (Feb. 1979)

CODEN: NBTNAE

**U.S. GOVERNMENT PRINTING OFFICE  
WASHINGTON: 1979**

---

For sale by the Superintendent of Documents, U.S. Government Printing Office, Washington, D.C. 20402  
Stock No. 003-003-      Price  
(Add 25 percent additional for other than U.S. mailing)

## PREFACE

This research was conducted under the sponsorship of the Department of Housing and Urban Development by the Applied Economics Program, the Center for Building Technology, National Engineering Laboratory, National Bureau of Standards. This report analyzes the technical and theoretical considerations which went into collection and analysis of the economics portion of Phase II of the Experimental Hazard Elimination Program (EHEP). This report develops a procedure for manually calculating the costs of lead-based paint abatement.

Appreciation is extended to Dr. Harold E. Marshall, Applied Economics Program, and Dr. John S. McConnaughey, Applied Economics Program, who reviewed the economic aspects of this paper. Appreciation is also extended to Mr. Harvey W. Berger, National Engineering Laboratory, who provided useful suggestions for improving the treatment of certain topics in this paper. Special appreciation is extended to Ms. Barbara Cassard, formerly with the Applied Economics Program, and Ms. Kimberly Hockenbery, Applied Economics Program, for their valuable assistance in the data analysis phase of this research effort.

## ABSTRACT

Public and private concern about the potential for lead poisoning in children due to the ingestion of lead-based paint chips has resulted in a Federally sponsored program to develop technologies by which the lead-based paint hazard may be eliminated from the nation's housing. The nature and design of the Experimental Hazard Elimination Program (EHEP) is thought to be unique in that it permitted the costs of the alternative lead paint abatement techniques to be rigorously analyzed.

The focus of this report is on the design, implementation and analysis of EHEP and the cost information it produced. Statistical analyses which permitted the development of econometric models capable of estimating abatement technique costs and expected contractor markup are described. Structural equations relating changes in the values of certain key factors to variations in direct cost and contractor markup are also presented. Guidelines, including a national deleading cost estimate, are given so that these econometric models can be used by municipal officials and building owners to estimate deleading costs as well as provide input to policy evaluation and formulation.

Key words: Abatement; building economics; building materials; cost estimation; econometric models; economic analysis; housing; lead-based paint; lead poisoning.

TABLE OF CONTENTS

|  | <u>Page</u> |
|--|-------------|
| PREFACE . . . . .  | iii         |
| ABSTRACT . . . . .   | iv          |
| LIST OF FIGURES . . . . .  | viii        |
| LIST OF DIAGRAMS . . . . .   | viii        |
| LIST OF TABLES . . . . .   | ix          |
| SI CONVERSION UNITS . . . . .  | xii         |
| 1. INTRODUCTION . . . . .  | 1           |
| 2. DESCRIPTION OF TECHNICAL APPENDICES . . . . .                                 | 2           |
| Appendix A: Details of the National Cost Estimates . . . . .                     | 4           |
| A.1 Lead-Based Paint Survey Data . . . . .                                       | 5           |
| A.2 Dwelling Unit Cost Computations . . . . .                                    | 7           |
| A.3 Housing Census Data . . . . .  | 18          |
| A.4 The National Cost Estimates by Region, Age, and<br>Type of Housing . . . . . | 19          |
| A.5 Conclusions . . . . .  | 27          |
| Appendix B: Description of Abatement Techniques. . . . .                         | 30          |
| B.1 Barrier Materials . . . . .  | 30          |
| B.1.1 Gypsum Wallboard . . . . .   | 30          |
| B.1.2 Plywood Paneling . . . . .   | 31          |
| B.1.3 Cementitious Coating . . . . .   | 31          |
| B.1.4 Gypsum Veneer Plaster . . . . .  | 31          |
| B.1.5 Vinyl-Coated Fabric . . . . .  | 31          |
| B.1.6 Cement-Coated Fiberglass . . . . .   | 32          |
| B.1.7 Melamine Coated Hardboard . . . . .  | 32          |

|   | <u>Page</u> |
|---|-------------|
| B.1.8 Aggregate Filled Paint . . . . .  | 32          |
| B.1.9 Gypsum Plaster with Metal Lath . . . . .  | 32          |
| B.1.10 Gypsum Impregnated Jute Fabric . . . . .                                       | 33          |
| B.1.11 Plywood on Floors . . . . .  | 33          |
| B.2 Paint Removal Methods . . . . .   | 34          |
| B.2.1 Infra-Red Heating Device . . . . .  | 34          |
| B.2.2 Solvent-Based Paint Remover . . . . .   | 34          |
| B.2.3 Electrical Heat Gun . . . . .   | 35          |
| B.2.4 Hand Scraping . . . . .   | 35          |
| B.2.5 Propane Torch . . . . .   | 35          |
| B.2.6 Dip Tank Method . . . . .   | 36          |
| B.3 Replacement of Components . . . . .   | 36          |
| Appendix C: Theoretical Considerations Underlying<br>Phase II of EHEP . . . . .       | 37          |
| C.1 Design Considerations . . . . .   | 37          |
| C.2 Statistical Techniques Utilized . . . . .   | 42          |
| C.2.1 Analysis of Variance . . . . .  | 45          |
| C.2.2 Multiple Regression . . . . .   | 48          |
| C.3 Parameter Estimates of the EHEP Cost Models . . . . .                             | 52          |
| C.3.1 Key Factor Impacts on Direct Costs . . . . .                                    | 53          |
| C.3.2 Key Factor Impacts on Contractor Markup . . . . .                               | 70          |
| C.3.3 Methods for Calculating Confidence<br>Intervals About Predicted Costs . . . . . | 75          |



|   | <u>Page</u> |
|---|-------------|
| Appendix D: Discussion of EHEP Phase II Data Characteristics and Empirical Implications . . . . . | 80          |
| D.1 Techniques for Deleading Walls and Trim . . . . .   | 80          |
| D.1.1 Plywood Paneling . . . . .  | 80          |
| D.1.2 Vinyl-Coated Fabric . . . . .   | 80          |
| D.1.3 Cement-Coated Fiberglass . . . . .  | 81          |
| D.1.4 Solvent-Based Paint Remover and Infra-red Heating Device . . . . .                          | 81          |
| D.1.5 Finish Painting . . . . .   | 82          |
| D.2 Ranges Over Which the Cost Models are Valid . . . . .   | 82          |
| D.3 Treatment of Intra-Unit and Inter-Unit Economies of Scale . . . . .                           | 84          |
| D.4 Potential Savings Resulting From the Use of the EHEP Phase II Cost Models . . . . .           | 86          |
| Appendix E: Methodology for Performing Hand Calculations . . . . .                                | 88          |
| E.1 Description of Method . . . . .   | 88          |
| E.2 Hand Calculation Worksheets . . . . .   | 96          |
| Appendix F: Listing of Computer Program . . . . .   | 124         |
| REFERENCES . . . . .  | 140         |

LIST OF FIGURES

|   | <u>Page</u> |
|---|-------------|
| A.1 Cumulative Distributions (Pittsburgh and Washington)<br>for Interior Walls in Pre 1940 Units . . . . .    | 8           |
| A.2 Cumulative Distributions (Pittsburgh and Washington)<br>for Interior Walls in 1940 - 1959 Units . . . . . | 9           |
| A.3 Cumulative Distributions (Pittsburgh and Washington)<br>for Interior Doors in Pre 1940 Units . . . . .    | 10          |
| A.4 Cumulative Distributions (Pittsburgh and Washington)<br>for Interior Doors in 1940 - 1959 Units . . . . . | 11          |
| A.5 Regional Breakdown Used in National Cost Estimate . . .   | 13          |
| A.6 Distribution of Total Deleading Cost Burden by Region. .  | 29          |

LIST OF DIAGRAMS

|   | <u>Page</u> |
|---|-------------|
| C.1 Random Assignment of Wall Abatement Techniques<br>in Occupied Units . . . . . | 40          |
| C.2 Random Assignment of Trim Abatement Techniques in<br>Occupied Units . . . . . | 44          |
| E.1 How to Calculate Direct Costs for Wall Techniques . . .                       | 90          |
| E.2 How to Calculate Direct Costs for Trim Techniques . . .                       | 92          |
| E.3 How to Calculate Minimum Bid Price . . . . .                                  | 95          |

LIST OF TABLES

| <u>Table</u>   | <u>Page</u> |
|--|-------------|
| A.1 Distribution of Lead-Based Paint in Housing by Type and Age . . . . .  | 6           |
| A.2 Dwelling Unit Abatement Costs in 1976 Dollars Including Markup for Pre 1940 Multifamily Dwelling Units (Walls Only -- 2.0 mg lead/cm <sup>2</sup> ) . . . . .  | 14          |
| A.3 Dwelling Unit Abatement Costs in 1976 Dollars Including Markup for Pre 1940 Multifamily Dwelling Units (All Trim -- 2.0 mg lead/cm <sup>2</sup> ) . . . . .    | 15          |
| A.4 Dwelling Unit Abatement Costs in 1976 Dollars Including Markup for Pre 1940 Single Family Dwelling Units (Walls Only -- 2.0 mg lead/cm <sup>2</sup> ). . . . . | 16          |
| A.5 Dwelling Unit Abatement Costs in 1976 Dollars Including Markup for Pre 1940 Single Family Dwelling Units (All Trim -- 2.0 mg lead/cm <sup>2</sup> ) . . . . .  | 17          |
| A.6 Distribution of Dwelling Units by Age and Region Used in Making National Cost Estimates . . . . .  | 20          |
| A.7 Number of Dwelling Units with a Lead Content on Walls of 2.0 mg lead/cm <sup>2</sup> or More. . . . .  | 21          |
| A.8 Cost of Deleading Pre 1940 Single Family Dwelling Units .  | 22          |
| A.9 Expected Cost in 1976 Dollars of Deleading the Nation's Housing by Region and Age/Type of Housing -- 2.0 mg lead/cm <sup>2</sup> . . . . .                     | 23          |
| A.10 Expected Cost in 1976 Dollars of Deleading the Nation's Housing by Region and Age/Type of Housing -- 1.5 mg lead/cm <sup>2</sup> . . . . .                    | 24          |
| A.11 Estimated Costs of Administering a Nationwide Program to Delead the Nation's Housing -- 2.0 mg lead/cm <sup>2</sup> . . . . .                                 | 25          |
| A.12 Estimated Costs of Administering a Nationwide Program to Delead the Nation's Housing -- 1.5 mg lead/cm <sup>2</sup> . . . . .                                 | 25          |
| C.1 Decision Model Symbol Identification . . . . .   | 41          |
| C.2 Occupied Unit Sound Wall Probability Function . . . . .  | 43          |

| <u>Table</u>   | <u>Page</u> |
|--|-------------|
| C.3 The Key Factors Determining Direct Cost Per Square Foot of Gypsum Wallboard . . . . .                              | 54          |
| C.4 The Key Factors Determining Direct Cost Per Square Foot of Plywood Paneling . . . . .                              | 55          |
| C.5 The Key Factors Determining Material Cost Per Square Foot of Plywood Paneling . . . . .                            | 56          |
| C.6 The Key Factors Determining Direct Cost Per Square Foot of Cementitious Coating and Veneer Plaster. . . . .        | 57          |
| C.7 The Key Factors Determining Material Cost Per Square Foot of Cementitious Coating and Veneer Plaster . . . . .     | 57          |
| C.8 The Key Factors Determining the Productivity of Labor in the Installation of Vinyl-Coated Fabric. . . . .          | 58          |
| C.9 The Key Factors Determining Material Cost Per Square Foot of Vinyl-Coated Fabric . . . . .                         | 58          |
| C.10 The Key Factors Determining the Productivity of Labor in the Installation of Cement-Coated Fiberglass . . . . .   | 59          |
| C.11 The Key Factors Determining Material Cost Per Square Foot of Cement-Coated Fiberglass . . . . .                   | 60          |
| C.12 The Key Factors Determining Labor Cost Per Linear Foot Using the Infra-Red Heating Device . . . . .               | 61          |
| C.13 The Key Factors Determining Labor Cost Per Linear Foot Using Solvent-Based Paint Remover . . . . .                | 62          |
| C.14 The Key Factors Determining Direct Cost Per Linear Foot of Paint Removal Using the Electric Heat Gun . . . . .    | 63          |
| C.15 The Key Factors Determining Direct Cost Per Linear Foot of Paint Removal Using the Hand Scraping Method . . . . . | 64          |
| C.16 The Key Factors Determining Direct Cost Per Unit of Component Replacement . . . . .                               | 65          |
| C.17 The Key Factors Determining Direct Cost Per Square Foot of Painting Walls and Ceilings . . . . .                  | 66          |
| C.18 The Key Factors Determining Direct Cost Per Unit of Painting Trim . . . . .                                       | 67          |

| <u>Table</u>  | <u>Page</u> |
|---|-------------|
| C.19 Explanatory Power of EHEP Phase II Cost Models . . . . .                       | 68          |
| C.20 Percentiles of the t Distribution for Selected<br>Degrees of Freedom . . . . . | 69          |
| C.21 The Key Factors Determining Markup . . . . .                                   | 70          |
| C.22 Basic Data Matrix . . . . .  | 71          |
| C.23 Preliminary Contract Package Assignment . . . . .                              | 73          |
| C.24 Variance-Covariance Matrix for Plywood Paneling<br>Cost Model . . . . .        | 78          |
| D.1 Boundary Values of Key Factors Used to Compute Direct<br>Costs . . . . .        | 83          |
| E.1 Index of the Worksheets Needed to Perform Hand<br>Calculations . . . . .        | 91          |
| E.2 Dwelling Unit Summary of Direct Costs . . . . .                                 | 93          |

## SI CONVERSION UNITS

The conversion factors and units contained in this report are in accordance with the International System of Units (abbreviated SI for Systeme International d'Unites). The SI was defined and given official status by the 11th General Conference on Weights and Measures which met in Paris, France in October 1960. For assistance in converting U.S. customary units to SI units, see ASTM E 380, ASTM Standard Metric Practice Guide, available from the American Society for Testing and Materials, 1916 Race Street, Philadelphia, PA. 19103. The conversion factors for the units found in this Standard are as follows:

### Length

$$1 \text{ in} = 0.0254^* \text{ meter}$$

$$1 \text{ ft} = 0.3048^* \text{ meter}$$

$$1 \text{ mil} = 0.001^* \text{ in}$$

$$1 \text{ yd} = 0.9144^* \text{ meter}$$

### Area

$$1 \text{ in}^2 = 6.4516^* \times 10^{-4} \text{ meter}^2$$

$$1 \text{ ft}^2 = 0.0929 \text{ meter}^2$$

$$1 \text{ yd}^2 = 0.836 \text{ meter}^2$$

### Volume

$$1 \text{ in}^3 = 1.639 \times 10^{-5} \text{ meter}^3$$

$$1 \text{ liter} = 1.00^* \times 10^{-3} \text{ meter}^3$$

$$1 \text{ gallon} = 3.785 \text{ liters}$$

### Temperature

$$^{\circ}\text{C} = 5/9 (\text{Temperature } ^{\circ}\text{F} - 32)$$

---

\* Exactly

LEAD PAINT ABATEMENT COSTS: SOME TECHNICAL  
AND THEORETICAL CONSIDERATIONS

1. INTRODUCTION

Through the "Lead-Based Poisoning Prevention Act"<sup>1</sup> Congress has delegated to the Department of Housing and Urban Development (HUD) the leadership role in developing the technical information which is required to determine the abatement procedures which will: (1) effectively deal with the lead-based paint (LBP) poisoning problem, and (2) promote economic efficiency in the allocation of resources to eliminate high levels of LBP in housing.

The Experimental Hazard Elimination Program (EHEP) is intended to contribute to the accomplishment of these goals in three ways. First, it permits the technical evaluation of experimental LBP abatement techniques in field deleading operations. Second, through the collection of cost data, it provides a framework for estimating the costs of future LBP hazard abatement operations. Third, it provides a data base against which procedures for estimating abatement costs can be tested for accuracy and ease of application.

EHEP consists of two phases. Phase I of EHEP involved deleading operations in 110 dwelling units. Thirty dwelling units were initially deleadinged in Washington, D.C.; the remaining 80 were deleadinged in Atlanta, Georgia, shortly thereafter. Phase II of EHEP involved deleading operations in 71 dwelling units in Boston, Massachusetts. Phase II differed from Phase I in that an experimental design was rigorously defined and controlled so that variations in abatement technique cost could be analyzed with regard to such important factors as type and condition of housing as well as prevailing supply and demand conditions for construction skills and materials. In addition, the cost information collected during Phase I of EHEP was used as a data base against which procedures for estimating abatement costs were validated.

The purpose of this report is to describe the technical and theoretical considerations which went into the planning, implementation, and analysis of EHEP Phase II and the cost information it produced. The level of detail and treatment of the technical and theoretical considerations implicit in EHEP Phase II provide firm technical underpinnings for the

---

<sup>1</sup> The "Lead-Based Paint Poisoning Prevention Act" (PL 93-695) was enacted by Congress on January 13, 1971 and amended (PL 93-151) on November 9, 1973. These acts provide for Federal participation, including grants to local governments for detection, treatment, and prevention of LBP poisoning.

research findings presented in Guidelines for Cost-Effective Lead Paint Abatement.<sup>1</sup> Such an analysis is necessary because the evaluation of the EHEP Phase II cost data is a significant aid in the identification of those LBP abatement techniques which promote economic efficiency at the dwelling unit level. Econometric models based on data from Phase II of EHEP are developed that (1) identify and quantify those variables which have the greatest impact on direct costs<sup>2</sup> and contractor markup, (2) show how the least-cost abatement technique may be identified, (3) provide guidelines for estimating abatement costs at the dwelling unit level or for a major program, and (4) provide baseline estimates for the expected national and regional deleading costs.

## 2. DESCRIPTION OF TECHNICAL APPENDICES

The bulk of this report is composed of a set of technical appendices. These appendices are designed to be self-contained and hence may be read independently. The major thrust of each appendix is to lay out in detail the theoretical, technical, and empirical considerations upon which the results of the EHEP Phase II cost analysis are based. In that sense the technical appendices are supporting evidence for results presented in the companion report Guidelines for Cost-Effective Lead Paint Abatement. The appendices go beyond the results of the companion report, however. In particular, a methodology for hand calculations is developed.

Details of the national cost estimates are presented in Appendix A. These estimates should be useful for planning purposes in that they show expected deleading costs by region, by age of housing, and by type of housing (single family, multi-family). Housing characteristics based on research findings in Analysis of Housing Data Collected in a Lead-Based Paint Survey in Pittsburgh, Pennsylvania Part II<sup>3</sup> are also presented.

These housing characteristics in conjunction with cost information may aid in policy planning and analysis in that they provide some insight into the expected scale of deleading operations in a dwelling unit. Estimates are presented for two levels of lead in paint. The first

---

<sup>1</sup> Robert E. Chapman and Joseph G. Kowalski, Guidelines for Cost-Effective Lead Paint Abatement, National Bureau of Standards, Technical Note 971 (In Press).

<sup>2</sup> Direct costs are the costs to the contractor for performing the deleading work. They include the costs of labor, material, and special equipment required to perform the task. They do not include any contractor markup for overhead and profit.

<sup>3</sup> Douglas R. Shier and William G. Hall, Analysis of Housing Data Collected in a Lead-Based Paint Survey in Pittsburgh, Pennsylvania Part II, National Bureau of Standards, Interagency Report 77-1293, June 1977.



estimate assumes that a minimum lead content of 2.0 mg/cm<sup>2</sup> serves as abatement criteria. The second estimate assumes a minimum lead content of 1.5 mg/cm<sup>2</sup>.

Appendix B is concerned with the engineering aspects of the alternative LBP abatement techniques.

The theoretical concepts implicit in the EHEP Phase II experimental design are presented in Appendix C. The structure of the EHEP Phase II experimental design is laid out in detail. The emphasis, however, is on identifying the necessary experimental criteria and showing how an experimental design may be tailored to the dual objectives of satisfying statistical requirements and recognizing budgetary constraints. An "efficient" experimental design is important because it maximizes the amount of information which can be collected and analyzed. Thus, these (theoretical) guidelines may be useful to planners and policy analysts concerned not only with collecting and analyzing LBP abatement costs but also with other housing problem areas such as rehabilitation and weatherization.

In Appendix D a critique of the cost data collected during Phase II of EHEP is presented. Special emphasis is given to those problems which resulted in the deletion of a small number of observations from the data base. Ranges, based on statistical tolerance intervals over which the cost models are valid and a discussion of the treatment of scale economies are also presented. Empirical tests which support the claim that savings resulting from the use of the EHEP Phase II cost models are approximately \$100 per dwelling unit are presented in the final section of Appendix D.

The methodology for using the EHEP Phase II cost models to make hand calculations is described in Appendix E. This appendix includes worksheets and sample calculations which illustrate how the cost models can be exercised. The major focus is on showing how the least-cost combination of abatement techniques may be identified.

The report concludes with a listing of the computerized cost estimating procedure. The computer program, written in the BASIC language, permits the user to estimate LBP abatement costs by inputting information on housing characteristics and wage and material prices via a time-sharing terminal. The output shows the least-cost combination of abatement techniques for each dwelling unit. An estimate of the contract bid price is also provided.

## APPENDIX A

### DETAILS OF THE NATIONAL COST ESTIMATES

Combining the results of this report with those of two recent publications,<sup>1,2</sup> has created an opportunity for estimating the national cost of lead paint abatement. The two reports by Shier and Hall provide information on the percentage of dwelling units (by age and building type) which contain lead painted surfaces; they also provide information on the average number of surfaces per dwelling unit which contain a given level of lead in paint. Such detailed information on the distribution of lead in dwelling units was not available before the two reports by Shier and Hall were published. It is important to recognize that such data is necessary if a meaningful national cost estimate is to be made. (A comparison of the results of the Pittsburgh survey to other cities is also necessary if the housing data is to be projected onto cities in other regions.) The results of the Pittsburgh survey and the cost estimation procedures of this report, provide a means for converting quantities of lead-based paint per dwelling unit into an estimate of the deleading costs for that dwelling unit. This information may then be projected onto regional and national scales. To do this, census data on the number of housing units by region, by age, and by building type is used.

In Chapter 1 of the companion report Guidelines for Cost-Effective Lead Paint Abatement, we asserted that it would cost between \$28 and \$35 billion to abate the lead-based paint hazard from the interiors of the nation's housing stock.<sup>3</sup> These figures are based on a set of assumptions detailing the amount of deleading work to take place and prevailing supply and demand conditions in the regional markets for labor and materials.

---

<sup>1</sup> Douglas Shier and William Hall, Analysis of Housing Data Collected in Lead-Based Paint Survey in Pittsburgh, Pennsylvania Part I, National Bureau of Standards, Interagency Report 77-1250, May 1977.

<sup>2</sup> Douglas Shier and William Hall, Analysis of Housing Data Collected in a Lead-Based Paint Survey in Pittsburgh, Pennsylvania Part II, National Bureau of Standards, Interagency Report 77-1293, June 1977.

<sup>3</sup> No estimate was made on the cost of abating the lead-based paint hazard from the exterior surfaces of a dwelling unit due to a general lack of information on the appropriate techniques for abatement, the cost of abatement, and the distribution of lead levels on exterior surfaces. It is important to point out that these figures do not include the costs of administering a nationwide lead paint abatement program. It will be shown in Section A.4 that including administration costs in the national estimate will increase the cost figures cited above by approximately 30 percent.

The purpose of this appendix is to describe our method and assumptions with respect to our manipulation of (1) the Pittsburgh lead-based paint survey data, (2) the EHEP Phase II cost models as applied to the results of (1), and (3) the Census of Housing data. This appendix will also present a summary of the national cost estimate broken down by region and type/age of housing.

#### A.1 LEAD-BASED PAINT SURVEY DATA

The second Shier and Hall report is based on housing data collected in a sample of approximately 3300 dwelling units during 1974 and 1975 in Pittsburgh, Pennsylvania. The findings of this report are summarized in three sets of tables. The first set of tables provides (for specified lead levels) by age and building type (single family or multifamily) data on the number and fraction of dwelling units, rooms, and surfaces that equal or exceed the specified lead level. Table A.1 was derived from the Pittsburgh survey results. The values of the dwelling unit specific characteristics associated with each age/type category may be thought of as characterizing a "statistical" dwelling unit of that age/type category. The percent at risk (dwelling units with lead levels equal to or exceeding the specified lead level,  $2.0 \text{ mg/cm}^2$  or  $1.5 \text{ mg/cm}^2$ ) columns in Table A.1 are calculated directly from the Pittsburgh survey data. The number of square feet of wall area is based on the average number of surfaces per dwelling unit at risk times an assumed value of 96 square feet per surface (12' by 8'). The number of linear feet of doors needing deleading is based on the average number of door surfaces needing deleading at the specified lead level times 8 linear feet (a four foot abatement height was assumed). The number of linear feet of windows reported in Table A.1 is based on the average number of window surfaces per dwelling unit at risk at the specified lead level times an assumed value of 7 linear feet per window.

Finally the number of linear feet of baseboard trim assumes that baseboards follow the lead distribution of windows and that the average number of rooms with lead painted windows will also contain lead paint on the baseboard trim. Forty-four linear feet of baseboard trim per room was assumed. This last mentioned procedure was necessary because the tables presented in Shier-Hall report do not contain data on baseboards. (The 44 foot figure is based on empirical data established during EHEP.) In using the data in Table A.1 to compile average deleading costs per dwelling unit, it was assumed that the smaller sets at risk (in percentage terms) were subsets of the larger sets at risk and that the largest percentage at risk for the three trim components held for all three of the trim components. Thus, for example, at the  $1.5 \text{ mg/cm}^2$  lead level, 78 percent of all dwelling units had lead painted doors, windows and baseboards.

It is important to point out that only those surfaces which contain lead paint will be treated. Consequently the costs of "cosmetic" treatment for other surfaces is not included in the cost estimates. Although some readers might object to this approach on aesthetic

TABLE A.1

DISTRIBUTION OF LEAD-BASED PAINT IN HOUSING BY TYPE AND AGE<sup>(a)</sup>

| Dwelling Unit Type/Age | mg Lead Per cm <sup>2</sup> | % at Risk (b) | Square Feet Walls | % at Risk | Linear Feet Doors | % at Risk | Linear Feet Windows | % at Risk | Linear Feet Baseboards |
|------------------------|-----------------------------|---------------|-------------------|-----------|-------------------|-----------|---------------------|-----------|------------------------|
| Single                 | 2.0                         | 62            | 450               | 71        | 33                | 71        | 31                  | 71        | 116                    |
| Pre40                  | 1.5                         | 72            | 469               | 78        | 34                | 77        | 33                  | 77        | 122                    |
| Multi                  | 2.0                         | 61            | 454               | 68        | 32                | 68        | 26                  | 68        | 102                    |
| Pre40                  | 1.5                         | 73            | 447               | 72        | 33                | 73        | 27                  | 73        | 107                    |
| Single                 | 2.0                         | 37            | 359               | 27        | 21                | 27        | 24                  | 27        | 93                     |
| 40-59                  | 1.5                         | 50            | 353               | 45        | 24                | 34        | 24                  | 34        | 93                     |
| Multi                  | 2.0                         | 21            | 384               | 29        | 14                | 29        | 15                  | 29        | 73                     |
| 40-59                  | 1.5                         | 29            | 381               | 46        | 15                | 28        | 15                  | 28        | 76                     |
| Single                 | 2.0                         | 21            | 268               | 23        | 18                | 23        | 21                  | 23        | 101                    |
| 60-75                  | 1.5                         | 33            | 278               | 49        | 23                | 27        | 19                  | 27        | 91                     |
| Multi                  | 2.0                         | 8             | 408               | 10        | 18                | 10        | 9                   | 10        | 55                     |
| 60-75                  | 1.5                         | 11            | 328               | 26        | 19                | 12        | 10                  | 12        | 63                     |

(a) The upper set of numbers are associated with lead reading of 2.0 mg/cm<sup>2</sup> while the lower set are associated with lead reading of 1.5 mg/cm<sup>2</sup>.

(b) This column refers to the percent of all the building elements at risk listed in the column on the right. Source in Douglas Shier and William Hall, Analysis of Housing Data Collected in a Lead-Based Paint Survey in Pittsburgh, Pennsylvania Part II, National Bureau of Standards Inter-agency Report 77-1293, June 1977, Appendix A.

grounds, the assumption that if only one surface in the room would require treatment all surfaces in the room would require treatment is contrary to the usual practice of HUD and local lead paint programs. Note that in cases where either gypsum wallboard or veneer plaster are used, the surface can be finished to the same color and texture as in the rest of the room.

All dwelling units (72 percent of the total) with lead painted walls were a subset within the 78 percent at risk for trim. This procedure maximizes the cost estimate per dwelling unit. A natural concern is whether the Pittsburgh survey results generalize to different regions in the country. While it would certainly be desirable to have survey results as reliable as those from Pittsburgh for different regions, there is some evidence that the Pittsburgh results will not prove to be anomalous. Evidence of this is contained in the first Shier-Hall report. A much smaller lead-based paint survey (100 dwelling units) was undertaken in Washington, D.C. It was found that "in most instances the distributions for Pittsburgh and Washington follow quite similar shapes. [This] suggests that there is very little difference in the wall lead levels for the two cities; the most pronounced difference occurs for doors in pre 1940 units."<sup>1</sup> Figures A.1 through A.4 are taken from the Shier-Hall report. Because of the close correspondence between Pittsburgh and Washington case results, we believe that assuming the Pittsburgh results projected onto other regions will not produce distorted cost estimates. In each figure the cumulative distribution for painted surfaces is given. The cumulative distribution is shown as a curve plotted against the lead level (in mg/cm<sup>2</sup>). Each curve shows the percent of the total number of painted surfaces which exceed a given lead level. For example, Figure A.1 shows that approximately 10 percent of the interior walls in Pittsburgh exceed a lead level of 3.0 mg/cm<sup>2</sup> whereas approximately 13 percent of the interior walls in Washington exceed a lead level of 3.0 mg/cm<sup>2</sup>.

## A.2 DWELLING UNIT COST COMPUTATIONS

Table A.1 of the previous section provided the basic information necessary to exercise the EHEP/Phase II cost models. Several supplementary steps were required however, in order to fulfill the data requirements of the EHEP models. In this section we shall describe these steps.

Since the national cost estimate is based on the aggregation of regional estimates, variations between regions in wage rates and material prices had to be introduced. Utilizing the cost indices found in Building Construction Cost Data, 1977<sup>2</sup> for labor and materials, it was possible

---

<sup>1</sup> Douglas Shier and William Hall, Analysis of Housing Data Collected in a Lead Based Paint Survey in Pittsburgh, Pennsylvania Part I, pp. 61-62.

<sup>2</sup> Robert S. Godfrey, ed., Building Construction Cost Data, 1977, Robert S. Means, Inc., Duxbury, Massachusetts, 1976.

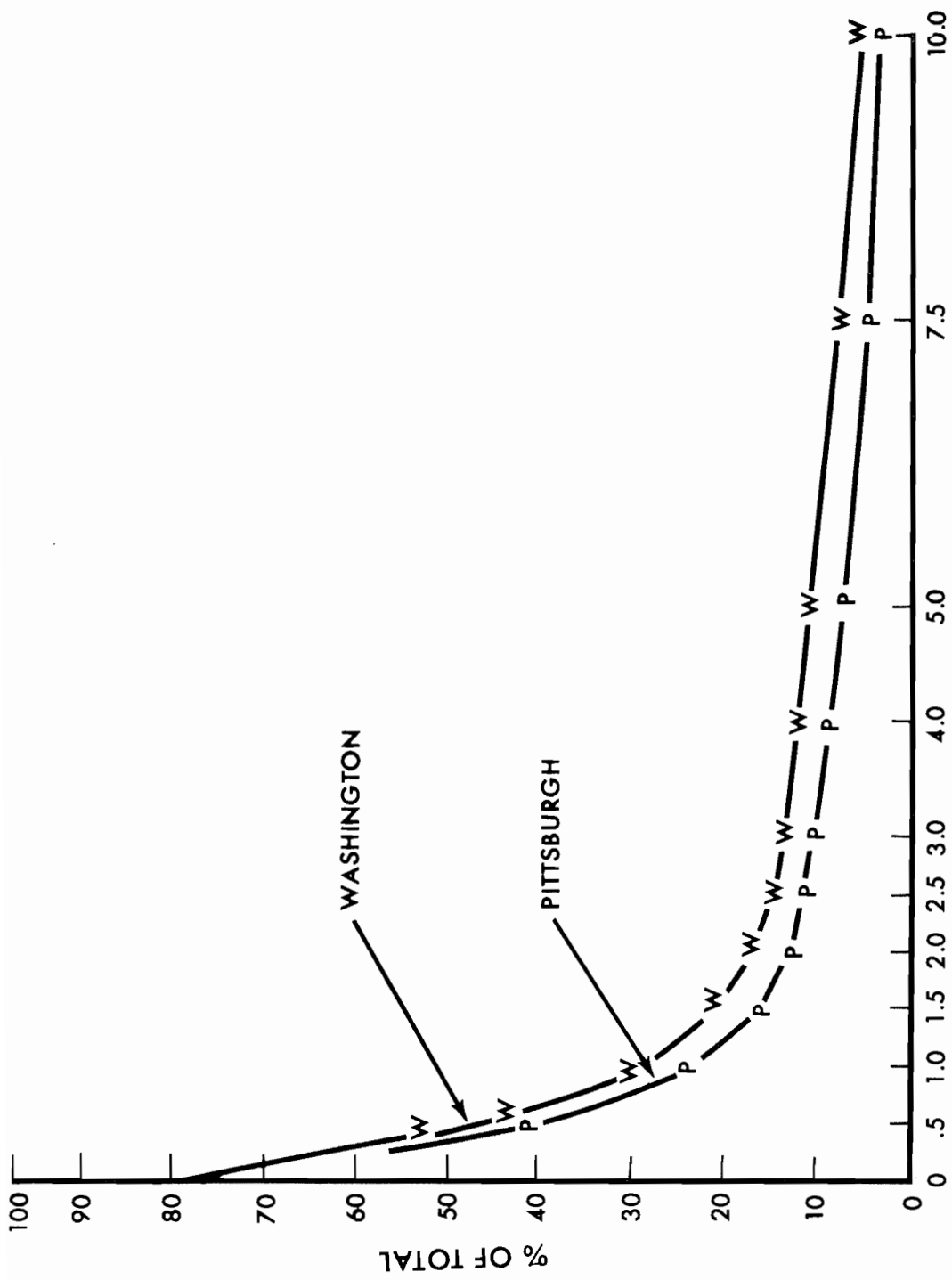

LEAD LEVEL (mg/cm<sup>2</sup>)

Figure A.1

Cumulative Distributions (Pittsburgh and Washington) for Interior Walls in Pre 1940 Units

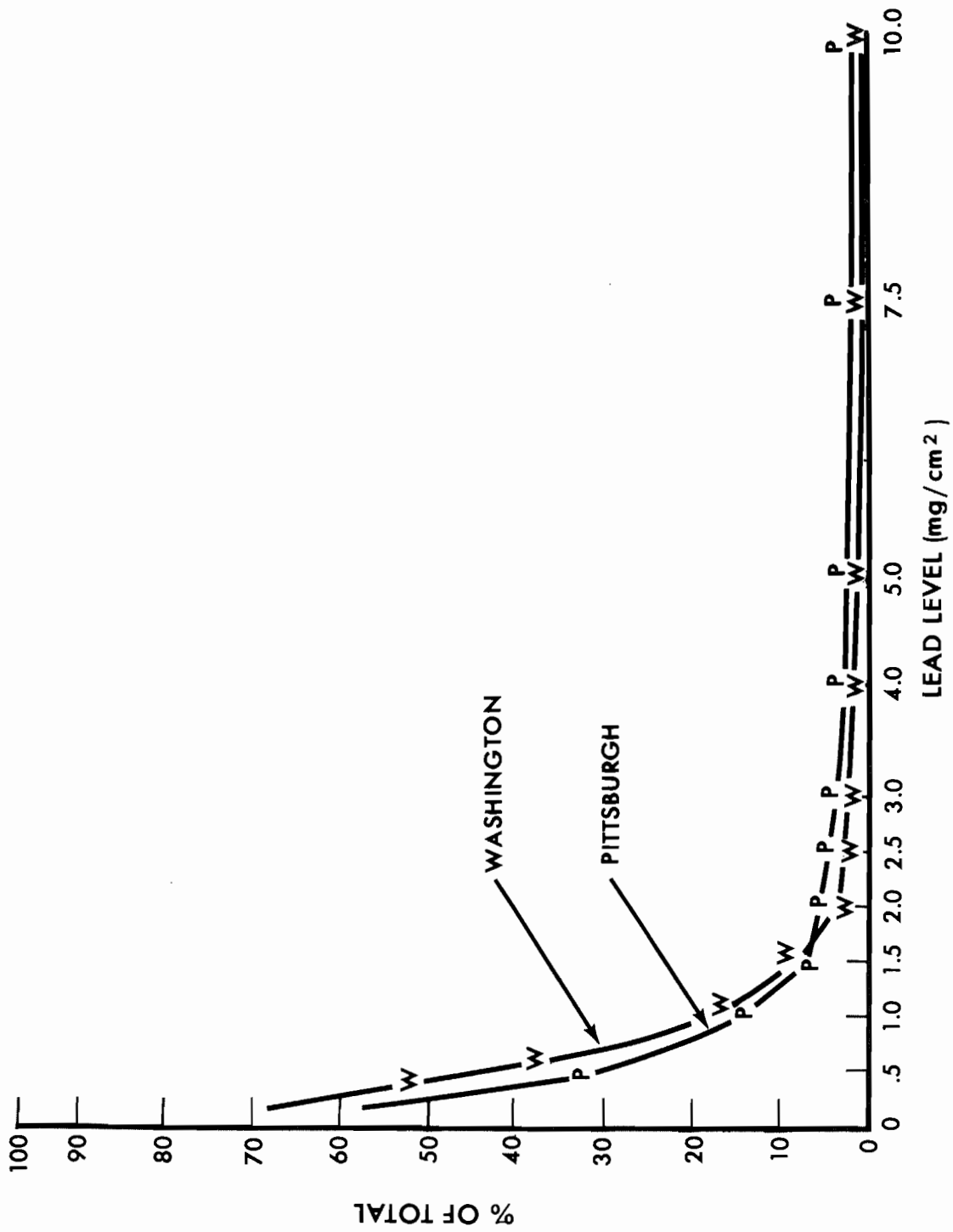

Figure A.2

Cumulative Distributions (Pittsburgh and Washington) for Interior Walls in 1940-1959 Units

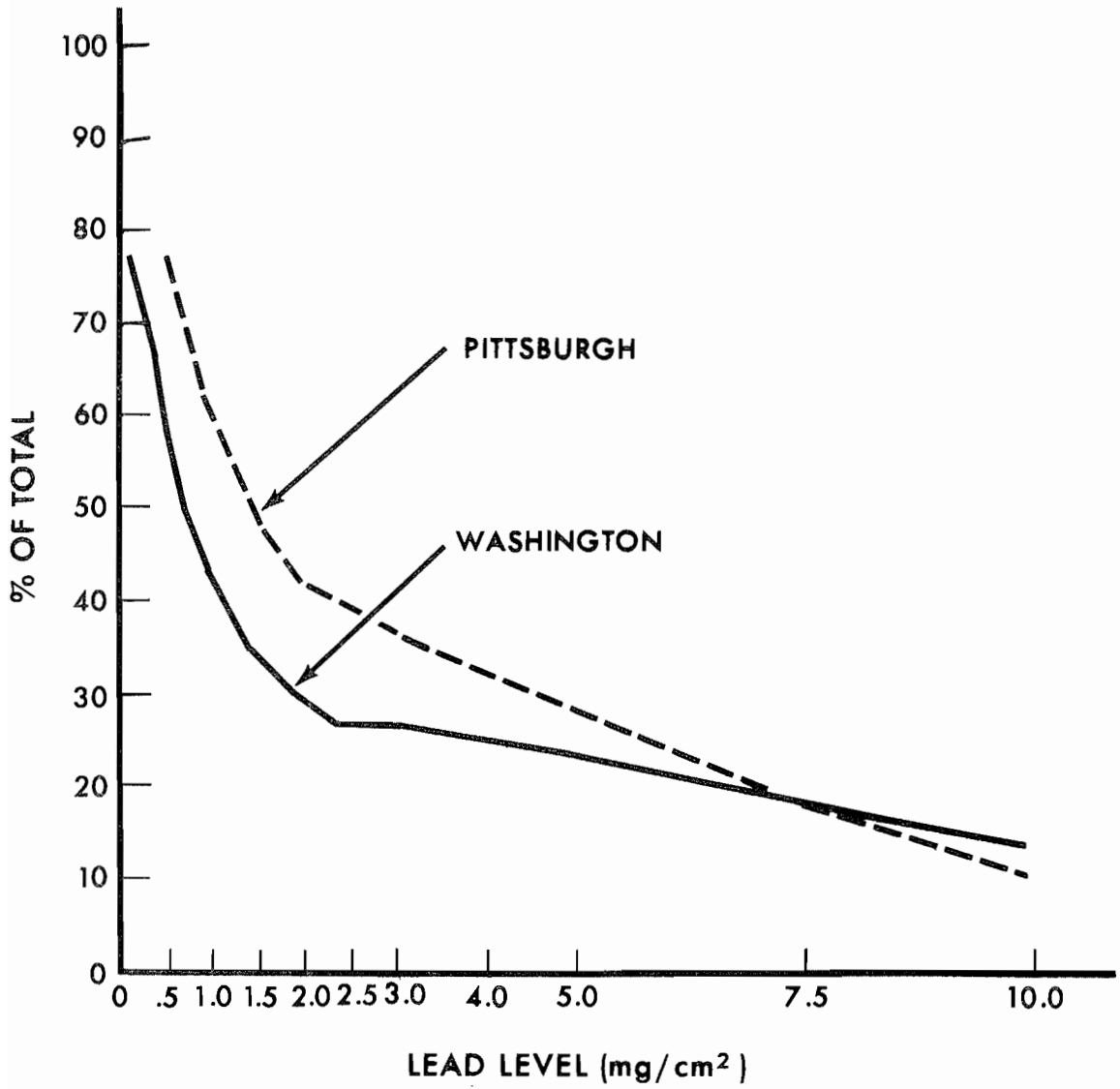

Figure A.3

Cumulative Distributions (Pittsburgh and Washington) for Interior Doors in Pre 1940 Units



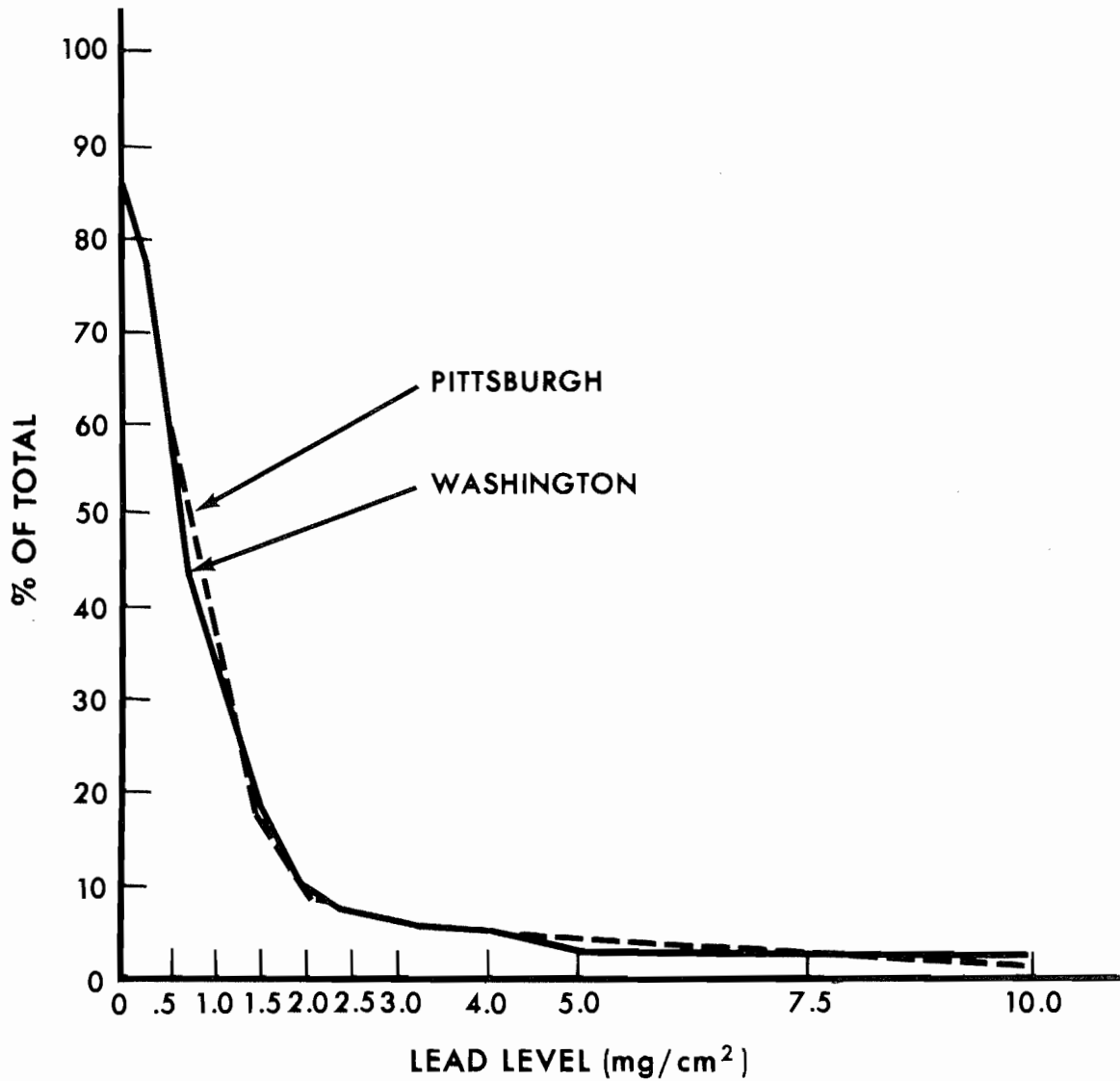

Figure A.4

Cumulative Distributions (Pittsburgh and Washington) for Interior Doors in 1940-1959 Units

construct weighted average (weighted by the percent of the regions population found in a given state) regional cost indices. All weights were computed using Boston, Mass. as the base point. The indices were then used to inflate or deflate the actual values of wages and material costs found in Boston for each technique in order to arrive at regional estimates for wages and material costs.

Data on the "statistical" dwelling unit by age/type category (See Table A.1) were then used in conjunction with regional estimates of wage rates and material prices to generate an estimate for deleading the "statistical" dwelling unit. All estimates were calculated using the "policy analysis" routine of a computer time-sharing program based on the EHEP/Phase II cost models. This routine calculates the direct costs for each wall and trim technique based on the representative ("statistical") values of the key factors. These direct cost figures are then averaged. A markup ratio based on the representative values of the key factors is also calculated. (The markup ratio calculated assumes that, on the average, three dwelling units will be in each contract.<sup>1</sup>) The markup ratio is then used to calculate the total cost (i.e. the sum of direct costs, overhead costs, and profit) of deleading the "statistical" dwelling unit. Figure A.5 shows the regional breakdowns used in making the national cost estimate. Tables A.2 through A.5 summarize the expected cost per dwelling unit for each region for selected building types and ages. The figures presented in Tables A.2 through A.5 do not include an estimate of the costs per dwelling unit associated with the administration of a lead-based paint program. (Details of how these costs were calculated are given in Section A.4.)

In the paragraph above it was stated that the direct costs of the six wall and four trim techniques were averaged for each "statistical" dwelling unit. This approach is equivalent to the assumption that the wall and trim techniques are uniformly distributed. Since this assumption is of prime importance in the development of the national cost estimates, we shall explore it in some detail.

The assumption of a uniform distribution of the abatement techniques used in computing the national costs estimates, as well as baseline program costs, can be supported in two ways. First, if an individual chooses among n abatement techniques without knowing their expected cost, each technique would be equally likely to be chosen. Hence, under individual choice a uniform distribution is not unreasonable. Second, suppose the techniques were assigned on the basis of engineering judgment or based on some other type of expert opinion. The abatement techniques used in Phase I of EHEP fit this scenario since they were assigned on the basis of engineering judgment. (Extensive laboratory tests were conducted prior to Phase I of EHEP to identify the performance characteristics of each of the techniques to be used in

---

<sup>1</sup> See Section D.3 for a discussion of the sizing of contract packages.

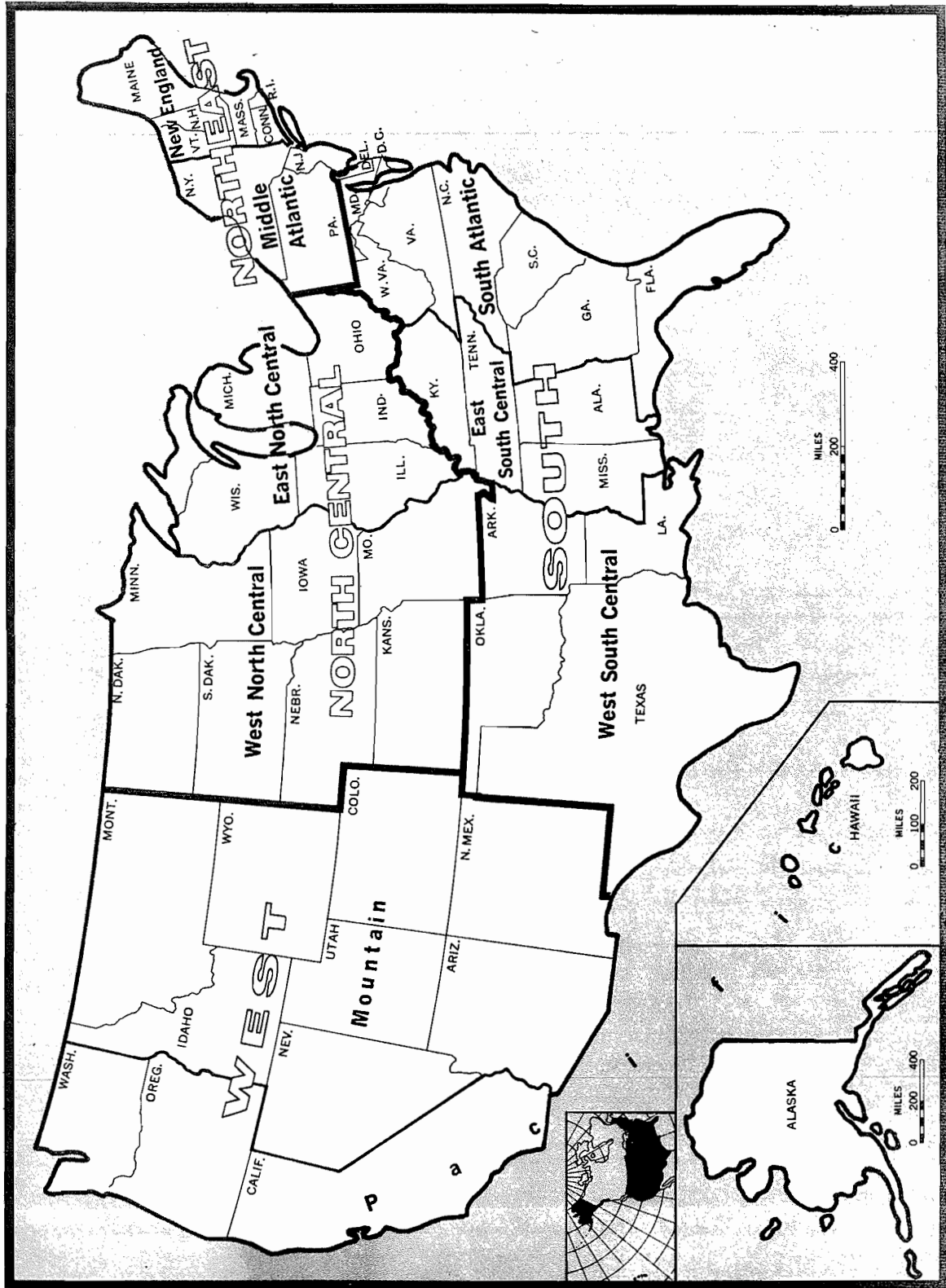

FIGURE A.5 REGIONAL BREAKDOWN USED IN NATIONAL COST ESTIMATE

TABLE A.2

DWELLING UNIT ABATEMENT COSTS IN 1976 DOLLARS INCLUDING  
 MARKUP FOR PRE 1940 MULTIFAMILY DWELLING UNITS  
 (WALLS ONLY -- 2.0 mg lead/cm<sup>2</sup>)

| Region                | Gypsum<br>Wallboard | Plywood<br>Paneling | Cemen-<br>titious<br>Coating | Veneer<br>Plaster | Cement<br>Fiber-<br>glass | Vinyl<br>Fabric | Ave rage <sup>a</sup> |
|-----------------------|---------------------|---------------------|------------------------------|-------------------|---------------------------|-----------------|-----------------------|
| New England           | 676                 | 658                 | 513                          | 556               | 813                       | 834             | 675                   |
| Mid Atlantic          | 701                 | 679                 | 591                          | 638               | 873                       | 834             | 719                   |
| East North<br>Central | 695                 | 675                 | 567                          | 614               | 855                       | 836             | 707                   |
| West North<br>Central | 657                 | 645                 | 475                          | 515               | 783                       | 830             | 651                   |
| South<br>Atlantic     | 566                 | 594                 | 425                          | 453               | 744                       | 791             | 596                   |
| East South<br>Central | 576                 | 598                 | 425                          | 453               | 744                       | 795             | 599                   |
| West South<br>Central | 513                 | 567                 | 430                          | 450               | 747                       | 764             | 579                   |
| Mountain              | 618                 | 626                 | 479                          | 514               | 786                       | 810             | 638                   |
| Pacific               | 649                 | 656                 | 613                          | 655               | 890                       | 805             | 711                   |

---

<sup>a</sup> The simple average of the six barrier techniques

TABLE A.3

DWELLING UNIT ABATEMENT COSTS IN 1976 DOLLARS INCLUDING  
 MARKUP FOR PRE 1940 MULTIFAMILY DWELLING UNITS  
 (ALL TRIM -- 2.0 mg lead/cm<sup>2</sup>)

| Region                | Heat Gun | Hand<br>Scraping | Solvent<br>Strip | Infra-Red | Average <sup>a</sup> |
|-----------------------|----------|------------------|------------------|-----------|----------------------|
| New England           | 363      | 466              | 500              | 396       | 431                  |
| Mid Atlantic          | 413      | 516              | 573              | 451       | 488                  |
| East North<br>Central | 398      | 502              | 551              | 435       | 471                  |
| West North<br>Central | 338      | 442              | 464              | 369       | 403                  |
| South Atlantic        | 299      | 402              | 411              | 326       | 359                  |
| East South<br>Central | 300      | 403              | 411              | 327       | 360                  |
| West South<br>Central | 297      | 400              | 410              | 324       | 358                  |
| Mountain              | 337      | 440              | 464              | 368       | 402                  |
| Pacific               | 421      | 526              | 590              | 462       | 500                  |

---

<sup>a</sup> The simple average of the four paint removal techniques

TABLE A.4

DWELLING UNIT ABATEMENT COSTS IN 1976 DOLLARS INCLUDING  
 MARKUP FOR PRE 1940 SINGLE FAMILY DWELLING UNITS  
 (WALLS ONLY -- 2.0 mg lead/cm<sup>2</sup>)

| Region                | Gypsum<br>Wallboard | Plywood<br>Paneling | Cemen-<br>titious<br>Coating | Veneer<br>Plaster | Cement<br>Fiber-<br>glass | Vinyl<br>Fabric | Average <sup>a</sup> |
|-----------------------|---------------------|---------------------|------------------------------|-------------------|---------------------------|-----------------|----------------------|
| New England           | 691                 | 665                 | 512                          | 557               | 824                       | 847             | 683                  |
| Mid Atlantic          | 716                 | 686                 | 591                          | 641               | 885                       | 847             | 728                  |
| East North<br>Central | 710                 | 682                 | 567                          | 616               | 867                       | 849             | 715                  |
| West North<br>Central | 672                 | 651                 | 473                          | 516               | 794                       | 843             | 658                  |
| South<br>Atlantic     | 579                 | 600                 | 423                          | 452               | 755                       | 804             | 602                  |
| East South<br>Central | 589                 | 604                 | 422                          | 453               | 755                       | 808             | 605                  |
| West South<br>Central | 525                 | 572                 | 427                          | 450               | 757                       | 776             | 585                  |
| Mountain              | 633                 | 632                 | 477                          | 515               | 797                       | 823             | 646                  |
| Pacific               | 663                 | 663                 | 614                          | 658               | 902                       | 818             | 720                  |

---

<sup>a</sup> The simple average of the six barrier techniques

TABLE A.5

DWELLING UNIT ABATEMENT COSTS IN 1976 DOLLARS INCLUDING  
 MARKUP FOR PRE 1940 SINGLE FAMILY DWELLING UNITS  
 (ALL TRIM -- 2.0 mg lead/cm<sup>2</sup>)

| Region                | Heat Gun | Hand<br>Scraping | Solvent<br>Strip | Infra-Red | Average <sup>a</sup> |
|-----------------------|----------|------------------|------------------|-----------|----------------------|
| New England           | 387      | 517              | 561              | 441       | 477                  |
| Mid Atlantic          | 444      | 576              | 645              | 505       | 542                  |
| East North<br>Central | 427      | 559              | 620              | 486       | 401                  |
| West North<br>Central | 358      | 489              | 519              | 409       | 444                  |
| South Atlantic        | 312      | 443              | 457              | 360       | 393                  |
| East South<br>Central | 313      | 444              | 458              | 360       | 394                  |
| West South<br>Central | 310      | 440              | 457              | 357       | 391                  |
| Mountain              | 356      | 487              | 519              | 408       | 443                  |
| Pacific               | 455      | 586              | 664              | 517       | 555                  |

---

<sup>a</sup> The simple average of the four paint removal techniques

the field.) Table 4.1 of the report, Economic Analysis of Experimental Lead Paint Abatement Methods: Phase I,<sup>1</sup> shows the number of dwelling units which were assigned to each abatement technique. The information in Table 4.1 permits the hypothesis that the choice of any wall technique was equally likely (i.e., a uniform distribution) to be tested. The results of the chi-squared goodness of fit test performed to test this hypothesis indicated that a uniform distribution was satisfactory. (The test statistic was 3.283 where  $X^2_{.05,6} = 12.592$ .) The following assumptions were made in performing this test: 1) cementitious coating and filled paint were combined; 2) plywood paneling was substituted for melamine paneling; and 3) the gypsum jute observations were divided equally among vinyl-coated fabric and cement-coated fiberglass. In each case the techniques which were grouped or substituted were almost identical (see Appendix B). In the case of trim techniques, engineering judgment tended to favor the more expensive techniques. Thus the assumption of a uniform distribution results in a lower rather than a higher estimate of expected costs.<sup>2</sup>

### A.3 HOUSING CENSUS DATA

The 1970 Census of Housing contains data on occupied dwelling units which cross tabulate for each tenure category the number of dwelling units by age and region.<sup>3</sup> However, since the tenure data does not correspond to the single family/multifamily classification used in the Pittsburgh survey, it was necessary to convert the tenure data by relying on data<sup>4</sup> found in the census volume on Metropolitan Housing Characteristics.<sup>4</sup> Table B-6 of that report contains for each of the four

---

<sup>1</sup> Robert E. Chapman, Economic Analysis of Experimental Lead Paint Abatement Methods: Phase I, National Bureau of Standards, Technical Note 922, September 1976.

<sup>2</sup> An alternative assumption would be to assume that the contractor performing the work could choose the least costly technique. This would imply that an averaging of abatement technique costs would overstate the baseline program costs. Unfortunately, such an approach is inconsistent with existing HUD policy which requires specifications to be written prior to invitation to bid. Another problem with this approach is that the planning and scheduling of program resources would be unnecessarily complicated since the preparation of budgetary estimates and specifications would have to wait until after the abatement contracts had already been awarded.

<sup>3</sup> U.S. Bureau of the Census, Census of Housing: 1970 Detailed Housing Characteristics Final Report HC(1)-B1, United States Summary, Table 22.

<sup>4</sup> U.S. Bureau of the Census, Census of Housing: 1970 Metropolitan Housing Characteristics Final Report HC, United States Summary, Table B-6.



major regions cross tabulated data which report for each occupancy category the number of single family units and multifamily units by age of dwelling unit. This data was used to establish percentage distributions of single and multifamily units for each occupancy category by age which was then used to convert the subregional age/tenure data into age/building type data. Tables No. 1261 and 1262 of the Statistical Abstracts<sup>1</sup> were utilized in a similar manner to derive estimates by region of the number of single and multifamily units constructed between 1970 and 1975. These data were added to the 1960-1970 data that were available in the 1970 Census of Housing. This permitted the most recent age category corresponding to the Pittsburgh survey data results to be included. Table A.6 resulted from these procedures. It was used to provide the basis of the estimates of the number of dwelling units at risk by region and age for each of the specified lead levels. Table A.7 presents the number of dwelling units at risk for walls with lead readings equal to or greater than 2.0 mg/cm<sup>2</sup>.

The last step was to multiply the number of units at risk by the cost (including markup) of deleading the "statistical" dwelling unit. In order to arrive at a single cost figure per unit, the results from tables like Tables A.2 and A.4 were used to compute the weighted average cost per unit based on all of the six wall techniques and four of the trim techniques (component replacement was not used in these calculations because of its extreme cost). Thus the product of the weighted average cost per dwelling unit for walls and trim (at a specified lead level) times the number of dwelling units at risk enabled us to arrive at regional estimates of the total cost of deleading walls and trim. Table A.8 is representative of these calculations. For both the 1.5 and 2.0 mg/cm<sup>2</sup> lead levels, there are six of these tables, one for each age/building type category.

#### A.4 THE NATIONAL COST ESTIMATES BY REGION, AGE, AND TYPE OF HOUSING

The tables presented in this section represent the end product of the previous three sections. They summarize, for the 1.5 mg/cm<sup>2</sup> (Table A.10) and 2.0 mg/cm<sup>2</sup> (Table A.9) levels, the national cost by region, age, and building type of deleading housing which contains lead-based paint.

In addition to the costs of physically installing the lead-based paint abatement techniques, (Tables A.9 and A.10) there will be costs associated with administering a lead-based paint program (Tables A.11 and A.12). In principle the costs of administering such a program must also be included in any assessment of the cost to the nation of a program or plan to eliminate the lead-based paint hazard from housing.

---

<sup>1</sup> U.S. Bureau of the Census, Statistical Abstracts of the United States: 1976, U.S. Department of Commerce, 97th ed., July 1976.

TABLE A.6

DISTRIBUTION OF DWELLING UNITS<sup>a</sup> BY AGE AND REGION  
USED IN MAKING NATIONAL COST ESTIMATES

| Region         | Pre '40<br>Single | '40-'59<br>Single | '60-'75<br>Single | Pre '40<br>Multi | '40-'59<br>Multi | '60-'75<br>Multi | Regional<br>Total |
|----------------|-------------------|-------------------|-------------------|------------------|------------------|------------------|-------------------|
| NE             | 975.5             | 684.0             | 680.1             | 1083.4           | 231.5            | 453.0            | 4107.5            |
| MA             | 3007.0            | 2245.3            | 1693.6            | 3457.8           | 1088.1           | 1322.8           | 12814.6           |
| ENC            | 3517.7            | 3115.1            | 2567.2            | 2334.3           | 412.1            | 1482.0           | 13428.4           |
| WNC            | 1674.4            | 1031.1            | 1072.8            | 981.5            | 367.0            | 594.0            | 5720.8            |
| SA             | 2146.8            | 2901.5            | 3675.0            | 527.2            | 791.7            | 1646.0           | 11688.2           |
| ESC            | 1061.0            | 1150.8            | 1164.8            | 241.0            | 303.4            | 421.1            | 4342.1            |
| WSC            | 1319.6            | 2045.0            | 1864.7            | 299.4            | 550.8            | 781.6            | 6861.1            |
| MT             | 518.2             | 890.0             | 921.7             | 205.7            | 199.8            | 612.3            | 3347.7            |
| PAC            | 1507.1            | 2905.9            | 2385.8            | 735.9            | 870.9            | 1865.3           | 10270.9           |
| NATIONAL TOTAL |                   |                   |                   |                  |                  |                  |                   |
|                | 15727.3           | 16968.7           | 16025.7           | 9866.2           | 4815.3           | 9178.1           | 72581.3           |

---

<sup>a</sup> In Thousands

TABLE A.7

NUMBER OF DWELLING UNITS<sup>a</sup> WITH A LEAD CONTENT  
ON WALLS OF 2.0 mg lead/cm<sup>2</sup> OR MORE

| Region         | Pre '40<br>Single | Pre '40<br>Multi | '40-'59<br>Single | '40-'59<br>Multi | '60-'75<br>Single | '60-'75<br>Multi | Regional<br>Total |
|----------------|-------------------|------------------|-------------------|------------------|-------------------|------------------|-------------------|
| NE             | 604.8             | 660.9            | 253.1             | 48.6             | 142.8             | 36.2             | 1746.4            |
| MA             | 1864.3            | 2109.3           | 830.8             | 228.5            | 355.7             | 105.8            | 5494.4            |
| ENC            | 2181.0            | 1423.9           | 1152.6            | 86.5             | 539.1             | 118.6            | 5501.7            |
| WNC            | 1038.1            | 598.7            | 381.5             | 77.1             | 225.3             | 47.5             | 2368.2            |
| SA             | 1331.0            | 321.6            | 1073.6            | 166.3            | 771.8             | 131.7            | 3796.0            |
| ESC            | 657.8             | 147.0            | 425.8             | 63.7             | 244.6             | 33.7             | 1572.6            |
| WSC            | 818.1             | 182.6            | 756.6             | 115.7            | 391.6             | 62.5             | 2327.6            |
| MT             | 321.2             | 125.5            | 329.3             | 42.0             | 193.6             | 49.0             | 1060.6            |
| PAC            | 934.4             | 448.9            | 1075.2            | 182.9            | 501.0             | 149.2            | 3291.6            |
| NATIONAL TOTAL |                   |                  |                   |                  |                   |                  |                   |
|                | 9750.7            | 6018.4           | 6278.5            | 1011.3           | 3365.5            | 734.2            | 27158.6           |

---

<sup>a</sup> In Thousands

TABLE A.8

COST OF DELEADING PRE 1940 SINGLE FAMILY DWELLING UNITS<sup>a, b</sup>

| Region | Wall Cost | Trim Cost | Total Cost | Present<br>National Cost |
|--------|-----------|-----------|------------|--------------------------|
| NE     | 412.9     | 329.9     | 742.8      | 6.2                      |
| MA     | 1356.6    | 1158.3    | 2514.9     | 21.1                     |
| ENC    | 1559.8    | 1306.2    | 2866.0     | 24.1                     |
| WNC    | 683.4     | 527.3     | 1210.7     | 10.2                     |
| SA     | 801.3     | 599.0     | 1400.3     | 11.8                     |
| ESC    | 398.1     | 296.6     | 694.7      | 5.8                      |
| WSC    | 478.2     | 366.5     | 844.7      | 7.0                      |
| MT     | 207.5     | 162.9     | 370.4      | 3.1                      |
| PAC    | 672.5     | 594.6     | 1267.1     | 10.6                     |

---

<sup>a</sup> In millions of 1976 dollars.

<sup>b</sup> Administrative costs are not included.

TABLE A.9

EXPECTED COST IN 1976 DOLLARS<sup>a, b</sup> OF DELEADING THE NATION'S HOUSING  
BY REGION AND AGE/TYPE OF HOUSING -- 2.0 mg lead/cm<sup>2</sup>

| Region                | Pre '40<br>Single  | Pre '40<br>Multi | '40-'59<br>Single | '40-'59<br>Multi | '60-'75<br>Single | '60-'75<br>Multi | Regional<br>Total | Percent<br>National<br>Cost |
|-----------------------|--------------------|------------------|-------------------|------------------|-------------------|------------------|-------------------|-----------------------------|
| New<br>England        | 742.8              | 763.8            | 207.7             | 44.0             | 120.1             | 29.6             | 1908.0            | 6.7                         |
| Mid<br>Atlantic       | 2514.9             | 2665.0           | 739.3             | 224.6            | 326.0             | 93.5             | 6563.3            | 23.1                        |
| East North<br>Central | 2866.0             | 1754.9           | 1002.8            | 83.1             | 482.3             | 102.5            | 6291.6            | 22.1                        |
| West North<br>Central | 1210.7             | 658.7            | 299.5             | 66.6             | 180.8             | 37.1             | 2453.4            | 8.6                         |
| South<br>Atlantic     | 1400.3             | 320.4            | 768.7             | 131.1            | 566.3             | 94.0             | 3280.8            | 11.5                        |
| East South<br>Central | 694.7              | 147.0            | 306.0             | 50.4             | 180.1             | 24.1             | 1402.3            | 4.9                         |
| West South<br>Central | 844.7              | 178.5            | 531.2             | 89.5             | 283.3             | 43.7             | 1970.9            | 6.9                         |
| Mountain              | 370.4              | 136.4            | 255.4             | 35.9             | 154.0             | 37.8             | 989.9             | 3.5                         |
| Pacific               | 1267.1             | 569.3            | 958.1             | 180.3            | 462.5             | 131.9            | 3569.2            | 12.7                        |
| NATIONAL TOTAL        |                    |                  |                   |                  |                   |                  |                   |                             |
| (Percent)             | 11,911.6<br>(41.9) | 7194.0<br>(25.3) | 5068.7<br>(17.8)  | 905.5<br>(3.2)   | 2755.4<br>(9.7)   | 594.2<br>(2.1)   | 28,429.4          | 100                         |

<sup>a</sup> In millions.

<sup>b</sup> Administrative costs are not included.

TABLE A.10

EXPECTED COST IN 1976 DOLLARS<sup>a,b</sup> OF DELEADING THE NATION'S HOUSING  
BY REGIONS AND AGE/TYPE OF HOUSING -- 1.5 mg lead/cm<sup>2</sup>

| Region                | Pre '40<br>Single  | Pre '40<br>Multi | '40-'59<br>Single | '40-'59<br>Multi | '60-'75<br>Single | '60-'75<br>Multi | Regional<br>Total | Percent<br>National<br>Cost |
|-----------------------|--------------------|------------------|-------------------|------------------|-------------------|------------------|-------------------|-----------------------------|
| New<br>England        | 865.8              | 883.5            | 305.3             | 55.9             | 178.4             | 40.1             | 2329.0            | 6.6                         |
| Mid<br>Atlantic       | 2932.7             | 3080.1           | 922.8             | 284.6            | 482.4             | 126.9            | 7829.5            | 22.3                        |
| East North<br>Central | 3341.8             | 2028.9           | 1357.2            | 105.4            | 714.5             | 138.9            | 7686.7            | 21.9                        |
| West North<br>Central | 1410.7             | 762.3            | 405.3             | 84.7             | 269.1             | 50.3             | 2982.4            | 8.5                         |
| South<br>Atlantic     | 1629.1             | 370.9            | 1040.5            | 166.8            | 844.6             | 127.5            | 4179.4            | 11.9                        |
| East South<br>Central | 808.4              | 170.2            | 414.3             | 64.2             | 268.6             | 32.7             | 1758.4            | 5.0                         |
| West South<br>Central | 981.9              | 206.6            | 719.2             | 113.9            | 421.8             | 59.5             | 2502.9            | 7.1                         |
| Mountain              | 431.4              | 157.9            | 345.6             | 45.6             | 229.0             | 51.3             | 1260.8            | 3.6                         |
| Pacific               | 1476.7             | 657.8            | 1297.0            | 228.2            | 682.9             | 179.5            | 4522.1            | 12.9                        |
| NATIONAL TOTAL        |                    |                  |                   |                  |                   |                  |                   |                             |
| (Percent)             | 13,878.5<br>(39.6) | 8318.2<br>(23.7) | 6807.2<br>(19.4)  | 1149.3<br>(3.3)  | 4091.3<br>(11.7)  | 806.7<br>(2.3)   | 35,051.2          | 100                         |

<sup>a</sup> In millions.

<sup>b</sup> Administrative costs are not included.

TABLE A.11

ESTIMATED COSTS OF ADMINISTERING A NATIONWIDE  
PROGRAM TO DELEAD THE NATION'S HOUSING --  
2.0 mg lead/cm<sup>2</sup>

| Administrative<br>Costs per<br><br>Dwelling<br>Unit | National Costs <sup>a</sup> By Age/Type of Housing |                  |                   |                  |                   |                  | Total  |
|---|--|------------------|-------------------|------------------|-------------------|------------------|--------|
|   | Pre '40<br>Single                                  | Pre '40<br>Multi | '40-'59<br>Single | '40-'59<br>Multi | '60-'75<br>Single | '60-'75<br>Multi |        |
| \$250   | 2,440  | 1,500            | 1,570             | 250              | 840               | 180              | 6,780  |
| \$350   | 3,410  | 2,110            | 2,200             | 350              | 1,180             | 260              | 9,510  |
| \$450   | 4,390  | 2,710            | 2,830             | 460              | 1,510             | 330              | 12,230 |

<sup>a</sup> In millions.

TABLE A.12

ESTIMATED COSTS OF ADMINISTERING A NATIONWIDE PROGRAM  
TO DELEAD THE NATION'S HOUSING --  
1.5 mg lead/cm<sup>2</sup>

| Administrative<br>Cost per<br><br>Dwelling<br>Unit | National Costs <sup>a</sup> By Age/Type of Housing |                  |                   |                  |                   |                  | Total  |
|--|--|------------------|-------------------|------------------|-------------------|------------------|--------|
|  | Pre '40<br>Single                                  | Pre '40<br>Multi | '40-'59<br>Single | '40-'59<br>Multi | '60-'75<br>Single | '60-'75<br>Multi |        |
| \$250  | 2,830  | 1,800            | 2,120             | 350              | 1,320             | 250              | 8,670  |
| \$350  | 3,960  | 2,520            | 2,970             | 490              | 1,850             | 350              | 12,140 |
| \$450  | 5,100  | 3,240            | 3,820             | 630              | 2,380             | 450              | 15,620 |

<sup>a</sup> In millions.

Administrative costs per dwelling unit are dependent upon the nature of a lead-paint abatement program. A program whose purpose is primarily aimed at identifying dwelling units with lead-based paint hazards and then attempting to achieve voluntary compliance to local health requirements will be quite different, in terms of administrative costs, from a program which pursues a more active policy of undertaking the actual installation of the abatement technique when voluntary compliance cannot be achieved. In the latter case administrative costs will also include the costs associated with administering the abatement contracts involving the installation of specific abatement techniques.

A large number of administrative scenarios are possible. Each scenario will have associated with it different levels of administrative costs per dwelling unit.

In order to achieve some order of magnitude estimate of administration costs we shall make the following assumptions. First, we shall not attempt to estimate the costs associated with any litigation that may be required to enforce compliance with a local housing code which specifies some hazardous level of lead-based paint in dwelling units. The liability problem has posed some difficult legal questions regarding the responsibilities of building owners and occupants and consequently will not be dealt with in this report. The reader interested in the legal implications of lead paint abatement policies is referred to the articles by Tepper<sup>1</sup> and Sarb<sup>2</sup>. Secondly, we shall assume that the primary administration costs are those associated with detecting lead-painted units, determining what corrective actions are called for, finding and selecting contractors, getting bids, and administering the actual contract.

Since little reliable data is available on the costs of administering what amounts to small rehab jobs in residential dwelling units, we have relied on the experience of the Boeing team which administered the Experimental Hazard Elimination Program and on conversations with contracting officials from local housing authorities in the Washington, D.C. area who have responsibility for administering rehabilitation contracts in residential units.

The per dwelling unit administrative cost estimates of installing lead-based paint abatement techniques ranges from \$250-\$450 per dwelling unit. This range estimate includes the following administrative tasks: surveying dwelling units for the presence of lead-based paint, preparing

---

<sup>1</sup> R. Bruce Tepper, Jr., "Lead Paint Poisoning: The Response in Litigation," St. Louis University Law Journal, Vol. 19, Winter 1974.

<sup>2</sup> Thomas B. Sarb, "Lead Paint Poisoning: Remedies for the HUD Low-Income Homeowner When Neglect is No Longer Benign," University of Michigan Journal of Law Reform, Vol. 8, Spring 1975.



specifications, making preliminary cost estimates, contacting contractors and advertising for bids, conducting prebid conferences, reviewing bids, inspecting work in progress, administering progress payments, writing reports, and other miscellaneous administrative tasks.

Table A.11 presents estimates of the national administrative costs associated with deleading dwelling units with a lead content on walls of 2.0 mg lead/cm<sup>2</sup> or more. The estimates are broken down by the age of the dwelling unit and are estimated for the end points of the range and for the mid-point. As seen in Table A.11, administrative costs would run from 6.8 billion to \$12.25 billion. Another way of putting it is that when administrative costs are included, the cost of deleading the nation's housing stock (2.0 mg lead/cm<sup>2</sup>) would range between 35 and 41 billion dollars.

Estimates of the national administrative costs associated with the 1.5 mg/cm<sup>2</sup> abatement criterion are presented in Table A.12. Administrative costs range from \$8.7 billion to \$15.6 billion. Total abatement costs are thus expected to range between \$44 billion and \$51 billion.

#### A.5 CONCLUSIONS

The installation of barrier materials or the removal of paint from trim surfaces are tasks which light rehabilitation or remodeling contractors have the capability of doing. Installing a barrier material is fundamentally a remodeling task, e.g., installing gypsum wallboard or covering a wall with a vinyl fabric material. Paint removal from trim surfaces is also a task which remodeling contractors are called on to do on occasion. Because of the great differences in housing characteristics throughout the nation, and because the amount of deleading required varies between units, the cost of deleading a dwelling unit will vary widely from region to region and among techniques. In order for a national cost estimate to be reliable, it must be based on a method of estimation which is sensitive to the diversity of conditions discussed above.

A credible estimate of the cost of deleading the nation's housing stock can be made if we know how much lead paint exists and how much it will cost to delead specific dwelling units. Evidence on the quantity of lead paint in housing is contained in the Pittsburgh survey while information on the cost of deleading is contained in this report.

Our results from the national cost estimates reported in this appendix are as follows:

1. The "incremental cost" of meeting a 1.5 mg/cm<sup>2</sup> abatement criterion versus a 2.0 mg/cm<sup>2</sup> abatement criterion is approximately \$9.25 billion.<sup>1</sup>

---

<sup>1</sup> This figure includes an administrative cost of \$350 per dwelling unit for both the 1.5 mg lead/cm<sup>2</sup> and the 2.0 mg lead/cm<sup>2</sup> abatement criteria.

In relative terms this represents an increase in national cost of almost 25 percent.

2. Almost half the nation's deleading cost burden is concentrated in eight states. Furthermore, this relationship holds both for the 1.5 mg lead/cm<sup>2</sup> and 2.0 mg lead/cm<sup>2</sup> abatement criteria. The eight states are located in the Middle Atlantic and East North Central regions. (See Figure A.6 for a detailed breakdown of the regional deleading cost burdens.)

3. The amount of deleading work required in any given dwelling unit remains fairly constant when the minimum abatement criteria is reduced from 2.0 mg/cm<sup>2</sup> to 1.5 mg/cm<sup>2</sup>. The substantial increase in regional and national deleading costs experienced in going from the 2.0 mg/cm<sup>2</sup> to the 1.5 mg/cm<sup>2</sup> abatement criterion is therefore due almost entirely to additions to the stock of dwelling units "at risk."

4. The proportions of the nation's deleading cost burden associated with the pre 1940 dwelling units declines only slightly (from 65 percent to 61 percent) when the minimum abatement criterion is reduced from 2.0 mg/cm<sup>2</sup> to 1.5 mg/cm<sup>2</sup>. This is true because the number of pre 1940 dwelling units "at risk" and the amount of deleading work they require exceed that of all post 1940 dwelling units.

5. The order of magnitude of deleading costs (\$30-\$50 billion) is roughly equivalent to the 1976 level of output of the remodeling and alteration construction sector.

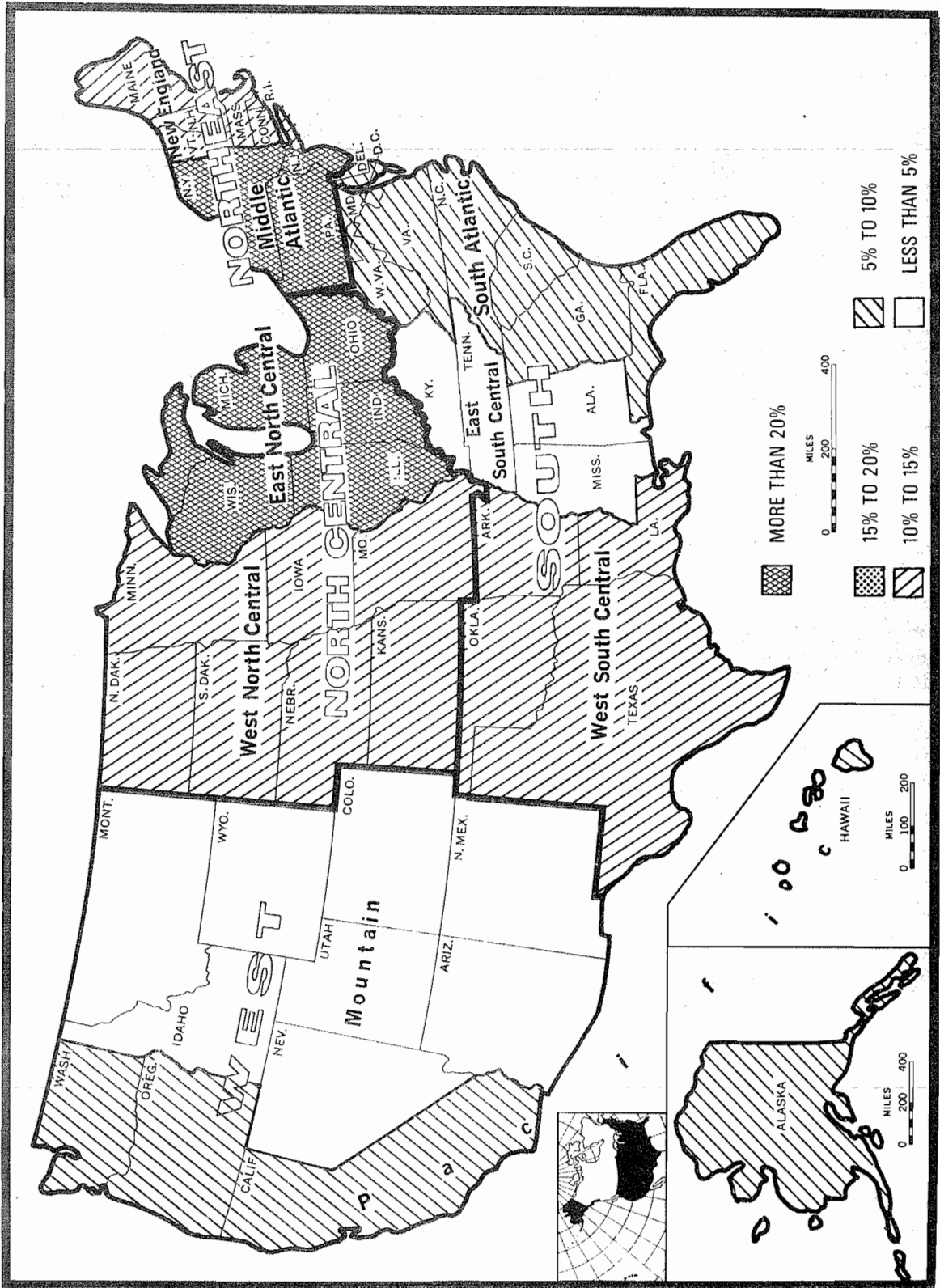

FIGURE A.6 DISTRIBUTION OF TOTAL DELEADING COST BURDEN BY REGION

## APPENDIX B

### DESCRIPTION OF ABATEMENT TECHNIQUES

This appendix is intended to supply background information on the three basic methods of lead-based paint (LBP) abatement. The three abatement methods are subdivided into individual abatement techniques. The abatement techniques are then described individually in some detail with regard to their composition, method of application, and/or any special skill or material/equipment requirements.

Since the body of this appendix is formed of excerpts from publications in which these abatement techniques are described in greater detail,<sup>1</sup> the interested reader is referred to the two reports by Boone et al.<sup>1</sup>

#### B.1 BARRIER MATERIALS

The complete stripping of LBP from surfaces as well as the removal and replacement of building components which are coated with LBP are defined here as LBP elimination methods. The effectiveness of such methods is essentially total. However, the application of these methods to large wall surfaces appears to be both impractical and prohibitively expensive. The application of materials, which are intended to act as barriers, is frequently the most reasonable approach to the abatement of LBP on planar surfaces. The effectiveness of barrier materials is therefore a function of the degree to which they prevent access to the existing LBP which they cover. The material's strength, durability and permeance are the primary characteristics that establish its effectiveness in LBP abatement.

##### B.1.1 GYPSUM WALLBOARD

Gypsum wallboard is a product which is composed of a thick layer of gypsum to which paper or other materials are bonded to provide a finished or finishable surface. It is intended for use on walls, ceilings, or partitions, and can be applied directly to existing surfaces or to wood or metal furring strips.

It can be applied directly to existing walls with adhesives and nails. The installed wallboard is prepared for painting by finishing the joints between the sheets with joint tape and compound. Nail heads are then covered with compound and both areas are sanded to a smooth finish.

---

<sup>1</sup> Thomas H. Boone, Harvey W. Berger, A. Philip Cramp, Herbert A. Jackson, The Demonstration of Experimental Lead Paint Hazard Abatement Methods in Washington, D.C., National Bureau of Standards, Interagency Report 75-761, June 1975, and Thomas H. Boone, Harvey W. Berger, A. Philip Cramp, Herbert A. Jackson, The Demonstration of Experimental Lead Paint Hazard Abatement Methods in Atlanta, Georgia, National Bureau of Standards, Interagency Report 75-974, December 1975.

#### B.1.2 PLYWOOD PANELING

This product is a 5/32 inch (4 mm) thick lauan mahogany plywood panel which has been treated with a multiple coat catalyzed varnish finish. The material is supplied in 4 x 8 feet panels (1.2 x 2.4 m) and is applied to existing walls with either fasteners or an adhesive. Pre-formed strips are used to cover vertical butted seams and as a molding at the ceiling line. Wood baseboards are applied over the paneling along the floor line.

#### B.1.3 CEMENTITIOUS COATING

The cementitious coating consists of portland cement, sand, and acrylic resin to which water is added to make a slurry. It can be tinted to desired colors by the addition of pigments recommended by the manufacturer.

The cementitious coating is viscous and has a rough texture. It can be applied by brush or roller or any other equipment designed to apply viscous filled coatings.

The surface must be clean and free from loose particles. Glossy surfaces must be roughened with an abrasive, and chaulky surfaces sealed with a sealer to ensure good adhesion. The applied coating has a final thickness of about 1/16-inch (about 1.6 mm).

#### B.1.4 GYPSUM VENEER PLASTER

This product is a component pre-packaged material which becomes plastic when mixed with water so that it can be trowel applied to form a highly polished finish or can be worked to achieve a textured finish. It may be applied to solid plaster walls which have first been treated with a vinyl polymer bonding compound to improve adhesion to the existing painted surfaces. The finished thickness of the plaster is approximately 1/8-inch (3.2 mm) thick. Skilled workmen are required for the satisfactory application of this product.

#### B.1.5 VINYL-COATED FABRIC

Vinyl-coated fabric is basically similar to wallpaper or vinyl-clad paper. Its strength and durability exceed that of the other two materials because of its combination of vinyl surface and textile fabric backing.

Vinyl-coated fabric may be installed on any wall surface that is free of dirt, grease, oil and moisture. The method used for hanging vinyl-coated fabric is the same as used for hanging wallpaper. The adhesive used depends upon the weight of the vinyl-coated fabric. These fabrics normally resist soiling and staining even by objects such as crayon, lipstick, or ink. A mild detergent and a sponge usually will remove most soils and stains. They conform to the bends and contours of most

surfaces and are installed readily by workmen who are familiar with wallpaper installation using ordinary hand tools and equipment.

#### B.1.6 CEMENT-COATED FIBERGLASS

This product consists of glass fabric impregnated with portland cement. It is applied to walls in the same manner as wallpaper, with a waterbase adhesive. As the portland cement absorbs moisture from the environment it hardens and becomes a fairly rigid and penetration-resistant material. A protective coating should be applied if the material is to be used in wet areas.

A clean substrate in good repair is necessary for adequate adhesion. The covering will, however, bridge minor voids and mask minor substrate imperfections.

The following barrier materials were used in Phase I of EHEP but were dropped from consideration during the Phase II deleading operations because of excess cost, logistical problems or similarities with other techniques that were used in Phase I.

#### B.1.7 MELAMINE-COATED HARDBOARD

This product is a 1/4-inch (6.4 mm) thick tempered hardboard to which a 1-1/2 mil (.038 mm) thick melamine film has been laminated to provide a serviceable, decorative finish. The material is supplied in 4 x 8 feet panels (1.2 x 2.4 m) and is applied to existing walls with fasteners or an adhesive. Pre-formed strips are used to cover vertical butted seams and as a molding at the ceiling line. Baseboards are applied over the paneling at the floor.

#### B.1.8 AGGREGATE FILLED PAINT

This coating is a latex based product which contains sand or other mineral aggregate which provides a thick finish comparable in texture to sand finished plaster.

Filled paint is viscous. The product used was formulated for application by airless spray equipment, but it and most other formulations can be applied using a brush or roller. It requires no mixing or thinning and it can be applied successfully to any surface which is free of dirt, oil or grease. Primers are not required for use on previously painted surfaces and thicknesses as high as 20 mils (0.02 inch or 0.05 cm) can be obtained with one coat. The finish texture, ranging from smooth to coarse, depends upon the aggregate quantity and particle size.

#### B.1.9 GYPSUM PLASTER WITH METAL LATH

Gypsum plaster is applied to a metal lath which serves as a support for the plaster and a means of adhesion to the surface being treated.

The lath is a netting of 20 gauge galvanized steel which is fastened to a surface with nails, staples or screws.

The plaster is usually applied in two stages resulting in a final thickness of 1/2-inch (1.3 cm). In the first application, wood fiber is added to the gypsum plaster to improve its working characteristics by making it easier to apply and to increase its adhesion to the metal lath. This first coat is applied by trowel to a uniform thickness of about 3/8-inch (1 cm). The plaster sets up (hardens) rapidly and must be applied quickly. Highly calcined gypsum plaster is used for the second or top-coat. This plaster contains a retarder which delays hardening so that the desired finish (smooth or textured) can be achieved. The final coat is about 1/8-inch (0.3 cm) thick. The finished dried surface is usually painted.

The application of plaster to lath should be done by skilled workmen. The temperature of the work area and surface should be above 50° F and adequate ventilation (for proper drying of the plaster) should be provided.

#### B.1.10 GYP SUM IMPREGNATED JUTE FABRIC

This wall covering product consists of jute fabric which is impregnated with uncrystallized gypsum (hydrated calcium sulfate). It is applied to walls in the same manner as wallpaper, with a water base adhesive which is recommended by the manufacturer of the fabric. As the gypsum absorbs moisture from the air, it hydrates, hardens and becomes a fairly rigid and penetration-resistant material. A protective coating can be applied if the material is to be used in wet areas.

A clean substrate in good repair is necessary for adequate adhesion. The covering will, however, bridge minor voids and mask minor substrate imperfections.

#### B.1.11 PLYWOOD ON FLOORS

Plywood may be used to cover-up lead painted exterior wood decks on porches. Warped and rotted boards are replaced with new or sound ones and a 15 lb. (6.8 kg) roofing felt is put down as an underlayment before installing the plywood.

Four by 8 feet (1.2 x 2.4 m) sheets of 3/8-inch (9.5 mm) A-B grade, exterior or marine plywood are used. All edges are treated with wood preservative and the sheets are nailed or screwed to the existing deck with their A grade surface up. All exposed edges are covered with wood trim and the new surface is painted with one coat of primer and two coats of exterior paint.

Skilled workmen are required to install plywood on existing porch decks with satisfactory workmanship. Although the job can be done with hand

tools, it can be accomplished much more easily with ordinary power tools such as electric drills and saws.

## B.2 PAINT REMOVAL METHODS

The safety of workmen and dwelling occupants is a primary consideration in the implementation of paint removal methods. Procedures should be taken to avoid the inhalation or absorption of lead fumes or dust. In addition, attention should be given to the potential fire hazard associated with the use of open flame paint removal techniques.

### B.2.1 INFRA-RED HEATING DEVICE

The infra-red heating device used in Phase II of EHEP consists of a propane burner whose flame is recessed in a metal reflector covered with a metal grid. When the flame is lit, the grid is heated. The device is held near the surface that is to be stripped. The heat radiating from the grid causes the paint to soften, swell and/or blister so that it can be removed easily from its substrate with metal scrapers.

This device is somewhat less hazardous than a propane torch because the open flame is recessed. Completely portable, it uses one pound disposable propane cylinders or a 25 pound refillable propane tank. The process of heating and scraping can be carried out by a single workman.

### B.2.2 SOLVENT-BASED PAINT REMOVER

A number of "industrial grade" paint removers may be used to remove LBP from windows, doors and other wood trim components. These viscous liquids are applied to both horizontal and vertical surfaces by brush, allowed to react with the lead paint coatings and then removed along with the softened paint using various metal scrapers.

Paint removers are extremely variable in their ability to penetrate and react with multiple layers of dried paint. The effectiveness of the remover depends not only on its own composition but also on the nature of the multi-layered coating to which it is applied. Most removers will react with only 2 to 4 layers of paint at a time. In such cases where more than that number of layers of paint is present, the remover-paint agglomeration must be removed and fresh remover applied as often as necessary to achieve complete removal.

Generally, the reaction time for paint removers is about one-half hour. The remover-paint waste, which is scraped from the treated surfaces, is collected on polyethylene drop cloths and discarded. Prior to light sanding and repainting, the surface is wiped with a water-saturated rag in order to remove any residue of remover-paint mixture.

Proper precautions regarding open flames, adequate ventilation and avoidance of contact with skin is necessary to assure the safe use of this class of products.



### B.2.3 ELECTRICAL HEAT GUN

It was seen earlier that when paint is heated sufficiently, it softens, swells and usually blisters so that it can be removed easily from its substrate with metal scrapers. One technique available for removing paint from doors, windows and other wood surfaces, by means of heat generation is a portable flameless electric hot air blowing device. It is quite effective in removing paint from wood substrates as demonstrated in laboratory tests; it also presents an apparent low risk of fire and injury to operators or bystanders.

This commercially manufactured device consists essentially of an air blower attached to a reinforced flexible plastic hose, with a cylindrical electric heater at the outlet. The heater is heavily insulated, so that it can be hand held while in operation. This apparatus is mounted on a stand which makes it quite mobile. It is capable of producing a strong stream of hot air at temperatures of between 350° and 1000°F (175° and 540°C). The working end of the device is very light in weight and a single workman can perform the continuous operations of heating the paint to its softening point and scraping it off with metal tools. Electrical circuits or portable generators supplying 20 ampere currents at 110-120 volts are required for operation of the hot air blower.

### B.2.4 HAND SCRAPING

Simple hand tools such as paint scrapers and putty knives may be used to remove loose and flaking paint. Electrical sanders may then be used to achieve the complete removal of paint which adhered too tightly to those surfaces for hand scraping.

The following paint removal methods were used in Phase I of EHEP but were dropped from consideration during the Phase II deleading operations because of excess cost, potential fire hazards, logistical problems, or similarities with other techniques that were used in Phase I.

### B.2.5 PROPANE TORCH

The open flame produced by a propane torch can be used to heat paint directly to the softening point so that it can be scraped off with metal tools. The process is easily carried out by a single workman using a one pound propane bottle.

Until recently, the use of propane torches had been quite widespread for this purpose. They are now falling into disfavor, however, due to the extreme fire hazard of an open flame (especially in occupied and furnished dwellings) and the danger of over-heating paints to the point of vaporization of the lead pigments.

#### B.2.6 DIP TANK METHOD

Commercial furniture stripping plants have facilities for removing old paint and varnish by totally immersing the object of interest in large tanks containing heated alkaline solvents in an aqueous medium.

Doors may be stripped by this process, requiring two to three hours of treatment during which time they are alternately soaked and scrubbed with heavy bristle brushes. The total stripping time is dependent on the type of paint, the number of paint layers and the temperature and strength of the solvent bath. Doors can be stripped with hinges and other hardware still attached. After the paint is completely removed the doors are washed with water, allowed to air dry, planed, and then returned to the dwelling unit from which they were taken where they are reinstalled and repainted.

#### B.3 REPLACEMENT OF COMPONENTS

Removal of doors, door frames, windows and frames, and other trim components and replacement with new materials is an accepted technique of LBP abatement. Replacement is used primarily when building components have deteriorated or are damaged beyond the point of serviceability. This method, in addition to restoring the building component to serviceability, also provides an opportunity to upgrade the quality of the dwelling unit significantly.

Carpentry skills are required for rehangng, fitting and remounting hardware. Custom carpentry may be required for replacing wooden sash windows and frames in some dwelling units.

## APPENDIX C

### THEORETICAL CONSIDERATIONS UNDERLYING PHASE II OF EHEP

The building component cost data collected in Phase II of EHEP were analyzed by using a series of statistical tests. Statistical analyses were needed because the data collected from Phase II deleading operations have some degree of uncertainty associated with them. This uncertainty is due to the fact that the data are based on only a small sample of units, not enough to capture all of the potential sources of variation due to the effects of changes in wage rate, the efficiency of labor, or the size of the abatement contract.

A statistical approach to the data analysis provides a methodology which identifies and quantifies differences which may exist in costs at the dwelling unit level. In addition, the use of statistical procedures permits probabilistic levels of significance to be attached to any conclusion regarding differences in direct costs or the expected bid price. Finally, a statistical approach permits the development and straightforward application of a model capable of predicting abatement technique costs.

The level of confidence (i.e., the probabilistic level of significance) which can be attached to any conclusion is dependent upon several factors. First, the underlying assumptions for any statistical procedure must be known and must be relevant to the data under consideration. Second, the relative importance of rejecting a hypothesis when it is true or accepting it when it is false must be assessed.<sup>1</sup> Finally, due to budgetary constraints on the amount of deleading work which could take place in EHEP, there was the trade-off between the size of the sample and the power of the test.<sup>2</sup>

#### C.1 DESIGN CONSIDERATIONS

A detailed experimental design was required to adequately measure variations in abatement technique cost and at the same time recognize the constraints under which EHEP had to operate.

---

<sup>1</sup> The probability of rejecting the formulated (null) hypothesis when it is true is denoted a type I error; the probability of accepting the alternative hypothesis when it is false is denoted a type II error.

<sup>2</sup> The probability of accepting the alternative hypothesis when it is true is denoted the power of the test. Other things being equal, the larger the sample, the greater is the power of the test.

The considerations which went into the planning of the Phase II EHEP experimental design relied heavily on the concepts presented in Natrella's text Experimental Statistics.<sup>1</sup>

Five requisites, presented in Natrella, determined the approach taken in the design portion of EHEP Phase II. They are:<sup>2</sup>

- (1) there should be a clearly defined objective;
- (2) the effects of the factors should not be obscured by other variables;
- (3) the results should not be influenced by conscious or unconscious bias in the experiment;
- (4) the experiment should provide a measure of precision; and
- (5) the precision should be sufficient to meet objectives.

The first requisite, really an overall goal of EHEP Phase II, was to identify the candidate abatement techniques, their methods of application, and appropriate criteria which had to be met for deleading operations to take place in order to adequately identify and measure the factors which cause technique costs to vary.

The second requisite involved the establishment of an experimental pattern which identified the "theoretical" key factors affecting technique costs (i.e., the technique, the occupancy status, the substrate condition, the contract package size, and the ownership category).

The third requisite involved the development of a decision model capable of assigning the individual abatement techniques to the stock of dwelling units in a random fashion. This greatly reduced the risk of systematic biases entering the experiment.

The fourth and fifth requisites involved replication and grouping of observations. The experimental design presented in Chapter 4 of the companion report, Guidelines for Cost Effective Lead Paint Abatement, showed that each of the factors thought to affect costs had several observations. In most cases this level of replication permitted the objective of the experiment to be met. However, in some instances it was necessary to group observations. The concepts underlying this "grouping" methodology will be explained in part C.2 of this appendix.

---

<sup>1</sup> Mary Natrella, Experimental Statistics, National Bureau of Standards, Handbook 91, August 1963.

<sup>2</sup> Mary Natrella, Experimental Statistics, p. 11-2.

We shall now turn to the decision model which permitted the abatement techniques to be randomly assigned to the stock of dwelling units.

The decision model used in this portion of EHEP is similar to an "urn problem" found in most texts on probability theory.<sup>1</sup> The implementation of the model made use of a flowchart to provide a structure for exercising the theoretical concepts. The flowchart shown in Diagram C.1 makes use of both decision blocks and process blocks.

In the Phase II EHEP experiment the term cell refers to an attribute within the framework of the model, for example in the wall experiment there is a cell with the following attribute: occupied - unsound walls - abatement technique A. Observations on the other hand are dwelling unit specific characteristics, for example an occupied dwelling unit having an unsound - dry wall surface. Also there may be more than one observation per dwelling unit, since any one dwelling may have both sound and unsound wall surfaces. The number of observations is initially set equal to 5.

Before turning to the flowchart and examining how the decision model operates, it is first necessary to review the symbols used and the implied functions they perform. The symbols are defined in Table C.1.

An illustration of how the model assigns the abatement techniques to the various dwelling units is now in order. The flowchart for the wall experiment, Diagram C.1, provides a convenient starting place. To start the process, a dwelling unit is chosen from the pool of dwelling units which met the criteria for deleading operations. At decision block 1 the occupied units are separated from the unoccupied units.

For brevity we shall trace through the flow chart for occupied units since the two branches of Diagram C.1 are identical. Next, dwelling units which contain more than one wall observation have their observations numbered consecutively from 1 to N. The first observation then proceeds to the next block, and continues through the model until it comes to a flag (block 7) which allows the second observation to move. This continues until all observations for the dwelling unit have been assigned. Returning to decision block 2, the observation moves to the next block where a random number is assigned. The value of the random number is then associated with a probability function to insure random assignment.

It is important to note that for occupied (or unoccupied) dwelling unit abatement techniques A and B are assigned on the basis of whether the wall surface is wet or dry rather than sound or unsound since relevant costs for these techniques are independent of substrate condition.

---

<sup>1</sup> See, for example, the text by Marek Fisz, Probability Theory and Mathematical Statistics, Third Edition, John Wiley and Sons, Inc., New York, 1963.

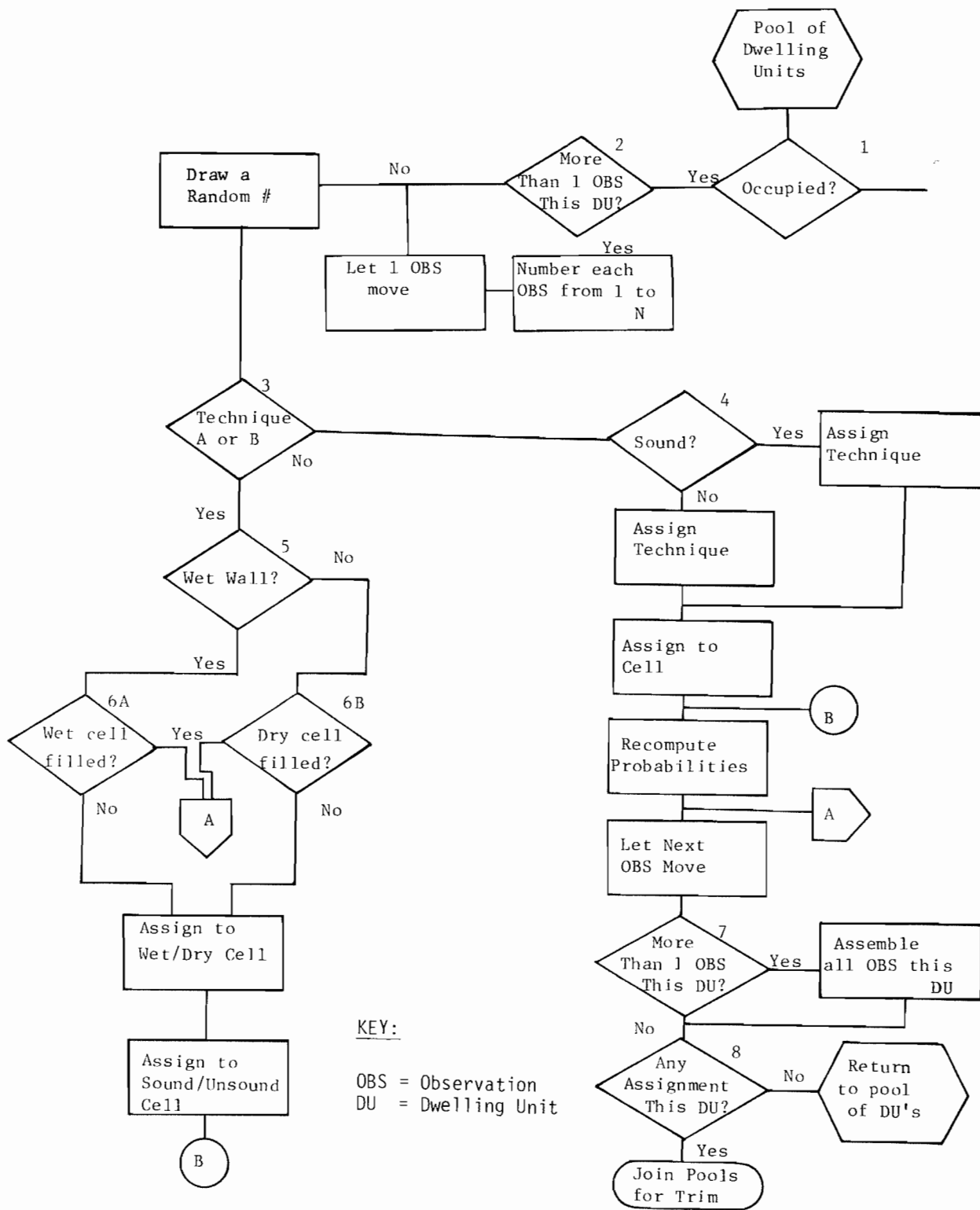
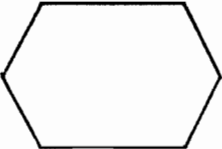
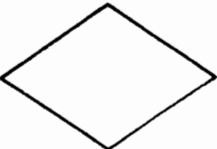
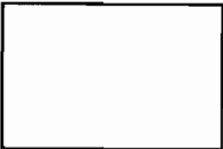

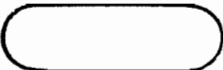
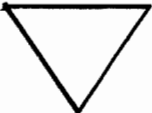

DIAGRAM C.1  
 RANDOM ASSIGNMENT OF WALL ABATEMENT TECHNIQUES IN OCCUPIED UNITS

TABLE C.1

DECISION MODEL SYMBOL IDENTIFICATION

| SYMBOL  | OPERATION  |
|---|--|
|    | <p>Pool of dwelling units available for wall surface abatement</p>         |
|    | <p>Either yes or no decision</p>   |
|   | <p>Processing of an observation</p>  |
|  | <p>Connections from one part of the chart to another</p>                   |
|  | <p>Pool of dwelling units available for door, window or trim abatement</p> |
|  | <p>Done</p>  |

When the observation reaches decision block 3, those assigned abatement technique A or B are sent to decision block 5 where wet wall surfaces are separated from dry wall surfaces. Should the wall observation have wet wall surfaces, decision block 6A determines whether or not the cell is already filled. In the event that the cell is filled, the observation is rerouted via connection A. Those observations not encountering their appropriate cell filled are assigned to that cell. Observations are then assigned to the appropriate cell in the sound/unsound wall experiment. Observations are then rerouted via connection B.

Returning to decision block 3, if neither technique A nor B was indicated, the wall condition is determined and one of the abatement techniques C, D, E or F is assigned to the dwelling unit.

This is accomplished by matching the random number of this observation against the occupied unit sound wall probability function given in Table C.2. Probability functions for other wall characteristics and other experiments are defined similarly.

For instance, if the random number falls between  $(R_a + R_b + R_c + R_d + R_e)/T$  and 1, technique F is selected. A similar argument holds for the assignment of the other abatement techniques.

The observation is then assigned to the appropriate cell and the probability function is recomputed. The next observation is then permitted to move. Dwelling units identified in decision block 2 as having more than one observation are separated in decision block 7 and are detained until all observations are assembled. Any dwelling unit which did not have at least one of its wall observations assigned to a cell is returned to the pool of dwelling units. Those dwelling units where a wall observation was placed in a cell are now candidates for door, window and trim abatement.

The selection of abatement techniques for doors, windows, and baseboard trim surfaces is identical. The trim abatement for occupied units is given schematically in Diagram C.2.

Those units which are occupied are separated from those which are unoccupied at decision block 1. Decision block 2 determines if enough trim is available for abatement; if there is, a random number is assigned to the dwelling unit. The random number is then matched against the occupied unit trim probability function and assigned an abatement technique. The observation is assigned to the appropriate cell and the probability function is recomputed. When this task is completed the next dwelling unit is selected from the pool. The one just assigned joins the done pool.

## C.2 STATISTICAL TECHNIQUES UTILIZED

To facilitate the analysis of the Phase II EHEP cost data, the statistical procedures of one-way analysis of variance and multiple regression



TABLE C.2

## OCCUPIED UNIT SOUND WALL PROBABILITY FUNCTION

| Technique Selected | Greater than or equal to          | Less than                         |
|--------------------|-----------------------------------|-----------------------------------|
| A                  | 0                                 | $R_a/T$                           |
| B                  | $R_a/T$                           | $(R_a + R_b)/T^*$                 |
| C                  | $(R_a + R_b)/T$                   | $(R_a + R_b + R_c)/T$             |
| D                  | $(R_a + R_b + R_c)/T$             | $(R_a + R_b + R_c + R_d)/T$       |
| E                  | $(R_a + R_b + R_c + R_d)/T$       | $(R_a + R_b + R_c + R_d + R_e)/T$ |
| F                  | $(R_a + R_b + R_c + R_d + R_e)/T$ | 1                                 |

where

$R_i$  = the number of observations required to fill the cell occupied -  
sound - technique  $i$ ;  $i = a, b, c, d, e, f$

$T$  = the total number of observations remaining required to fill all  
the occupied cells, i.e.,

$$T = R_a + R_b + R_c + R_d + R_e + R_f$$

\*Observations with a random number less than  $(R_a + R_b)/T$  are assigned to either technique A or B and sent from decision block 3 to decision block 5.

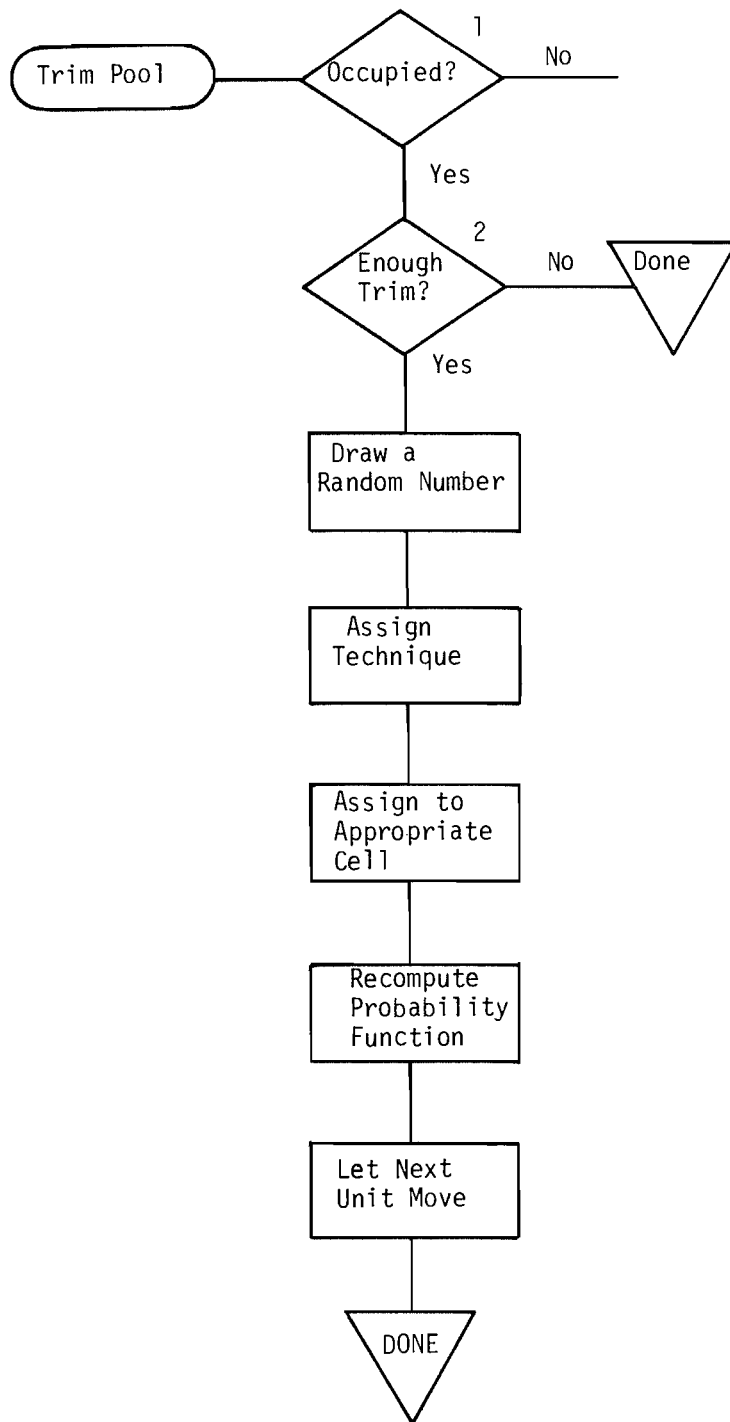

DIAGRAM C.2

RANDOM ASSIGNMENT OF TRIM ABATEMENT TECHNIQUES IN OCCUPIED UNITS

were used. Both were selected because the type and nature of the data collected indicated that rather sophisticated methods were needed. Furthermore, they permit the data to be reduced to a form from which a prediction mechanism can be constructed. The application of these statistical procedures to the cost data was accomplished through the use of the NBS computer package OMNITAB II.<sup>1</sup> OMNITAB II was selected because of its availability and its highly reliable statistical programs.

Also, its numerical and graphical output provide an effective way of testing if any of the underlying assumptions have been violated.<sup>2</sup>

### C.2.1 ANALYSIS OF VARIANCE

The initial testing of the Phase II EHEP cost data involved the analysis of variance for a one-way classification.<sup>3,4</sup> As a statistical procedure, the one-way analysis of variance permits the testing of the null hypothesis, that the observed differences among two or more sample means can be attributed to chance, versus the alternative hypothesis, that the observed differences are indicative of actual differences among the means of the corresponding populations.<sup>5</sup> That is, it provides a way to test the hypothesis that, for a particular building component, the observed differences in direct costs for each abatement technique are attributable to chance versus the hypothesis that they indicate that real differences in direct costs do exist between the different abatement techniques. On the surface this may seem a rather simplistic statement since the chance of having two or more abatement techniques

---

<sup>1</sup> David Hogben, Sally T. Peavy, Ruth N. Varner, OMNITAB II User's Reference Manual, National Bureau of Standards, Technical Note 552, October 1971.

<sup>2</sup> If the power of a test is relatively insensitive to the relaxation of one or more of its underlying assumptions, it is referred to as a robust test. In the absence of robustness, some means of testing for violation of the underlying assumptions is required.

<sup>3</sup> The analysis of variance used here is referred to as one-way since the data being analyzed are subject to only one dimension of classification, the abatement technique.

<sup>4</sup> Due to the nature of the experimental design discussed in section C.1, less emphasis was placed on the use of the analysis of variance in Phase II of EHEP than in Phase I. The OMNITAB II analysis of variance package does however have several features which make a discussion of the technique and some of its implications quite useful.

<sup>5</sup> An introduction to the analysis of variance is given in K. A. Brownlee, Statistical Theory and Methodology in Science and Engineering, John Wiley and Sons, Inc., 1960. For a more mathematical treatment see H. Scheffe, The Analysis of Variance, John Wiley and Sons, Inc., 1959.

with identical direct costs is very unlikely. Because of uncertainty, however, finding a difference does not necessarily indicate that one is significantly more or less expensive than the other. What is of central importance here is that an analysis of variance approach permits the statement to be made with a given level of confidence that there does or does not exist, for a given building component, a significant difference in direct costs for different abatement techniques.<sup>1</sup> The acceptance or rejection of the null hypothesis was based on whether or not the resulting F ratio was greater than the theoretical F ratio for the predetermined confidence level.<sup>2</sup> For the purposes of EHEP, the set of abatement techniques may be considered to be fixed. This has a consequence that the type of analysis of variance model under consideration is a fixed effects model.<sup>3</sup>

The data base was prepared for analysis by first separating it into its respective building components.<sup>4</sup> The data were then subdivided within each building component into abatement techniques. To provide an adequate point of reference from which abatement techniques could be compared, they were tabulated with respect to their dwelling units. Once the data base was arranged in this way, it was possible to read the relevant information directly from the Dwelling Unit Cost Data Form. However, before

---

<sup>1</sup> A confidence level of 95 percent does not mean that the null hypothesis is 95 percent true; it is either true or false. It implies that if the null hypothesis were true and the experiment was repeated over and over under identical circumstances 95 out of every 100 times the null hypothesis would be accepted.

<sup>2</sup> The acceptance region for the null hypothesis is given by the 95 percent  $F_{k, \sum_{i=1}^k n_i - k}$  where point of the F distribution with k-1 and  $\sum_{i=1}^k n_i - k$  degrees of freedom,

where k equals the number of abatement techniques and  $n_i$  equals the number of experimental observations for the ith technique. The F ratio resulting from the observed data is computed by dividing the among-techniques mean square by the within-techniques mean square.

<sup>3</sup> This assumption has some interesting theoretical implications in that it permits, generally speaking, more definitive statements to be made with the same set of data than other analysis-of-variance models. Future studies may indicate that additional abatement techniques are feasible in which case the assumption of a fixed effects model would be a bit stronger than required. In the absence of any such indication, however, it appears that the assumption of a fixed effects model is justified.

<sup>4</sup> It should be recalled that building components denote walls, doors and frames, windows and frames, and other miscellaneous trim.

the actual analysis could begin, it was necessary to reduce all cost data to a per unit basis. To accomplish this, the figures for labor costs, material/equipment costs, the quantity of surface deleaded, and the total person-hours expended were calculated. At this time several other variables which were involved in the analysis were computed. These were the average wage rate and the productivity of labor. The average wage rate reflects the average wage which would be paid per person-hour for a given abatement technique excluding the costs of finish painting. It may be expressed mathematically as

$$AWR = \sum_{i=1}^n P_i W_i,$$

where AWR = average wage rate,

$P_i$  = the proportion of the total person-hours expended by the  $i$ th labor type,

$W_i$  = the wage of the  $i$ th labor type, and

$$\sum_{i=1}^n P_i = 1.$$

The average productivity of labor is the number of units<sup>1</sup> which can be processed in one person-hour, that is the total number of units processed divided by the total person-hours expended.

The analysis of variance model was applied to data for each building component on per unit direct cost, per unit labor cost, per unit material/equipment cost, and the productivity of labor.

To insure that the underlying assumptions were not violated,<sup>2</sup> two backup tests were used. Both tests were provided in the OMNITAB II output package. First, the Cochran C test<sup>3</sup> was used to test the validity of the assumption that the variance of the abatement techniques was the same. Second, should the assumption of an underlying normal distribution be

---

<sup>1</sup> Units denote square feet, linear feet, the number of doors and frames, or windows and frames.

<sup>2</sup> The sample observations were assumed to be independent normally distributed random variables with equal variance.

<sup>3</sup> W. J. Dixon and F. J. Massey, Introduction to Statistical Analysis, McGraw-Hill Book Company, 1957, p. 180.

unjustified, the Kruskal-Wallis H test was used.<sup>1</sup> The Kruskal-Wallis H test was selected because it is a non-parametric test which uses the ranks of the experimental observations and avoids any assumption about the underlying distribution.

If the one-way analysis of variance results indicated that the difference between abatement techniques for a particular building component was not attributable to chance, a pair wise multiple comparison of means was performed. The purpose of this test was to group the abatement techniques into categories such that the means of the abatement techniques within a category were not significantly different at the 95 percent confidence level, but that the means in different categories were significantly different at this level. The grouping into categories was accomplished through the application of the Scheffe method.<sup>2</sup> This method was selected since it did not require an equal number of observations for each abatement technique.<sup>3</sup> This is the approach which was used in Phase I of EHEP so that sample size could be increased by grouping observations. Generally speaking, during Phase II of EHEP there were enough observations on each abatement technique that grouping into cost categories was not necessary.

#### C.2.2 MULTIPLE REGRESSION

The design of the Phase II EHEP experiment permitted an in-depth analysis of the structure and determinants<sup>4</sup> of direct cost and bid price through the use of multiple regression.

In the course of the analysis of the Phase II cost data, two measures of per unit direct cost were used as response variables: (1) the cost per square foot, and (2) the cost per linear foot. Explanatory variables (those which determine per unit direct cost) included the average

---

<sup>1</sup> K. A. Brownlee, Statistical Theory and Methodology in Science and Engineering, pp. 194-196.

<sup>2</sup> K. A. Brownlee, Statistical Theory and Methodology in Science and Engineering, pp. 252-254.

<sup>3</sup> In the event that an equal number of observations for each technique does occur, the Newman-Keuls-Hartley method may be used. Details of this method are given in G. W. Snedecor, Statistical Methods, Fifth Edition, Iowa State University Press, 1956.

<sup>4</sup> The term structure is used to denote the basic relationship between the variables and how they affect direct cost; determinants refer to specific variables which affect direct costs.

wage rate and the quantity of surface deleaded. Throughout the analysis, the structure of the model was assumed to be of the linear form

$$PDC = \beta_0 + \sum_{j=1}^m \beta_j X_j + e,$$

where PDC = per unit direct cost, the response variable,

$\beta_0$  = the intercept term,<sup>1</sup>

$\beta_j$  = the coefficients of the explanatory variables,

$X_j$  = the explanatory variables, and

$e$  = the error term.

The methodology through which the underlying structure and determinants of per unit direct cost were analyzed involved a four stage iterative process of (1) selecting a model, (2) estimating the coefficients,  $\beta_j$ , (3) testing the validity of the underlying assumptions, and (4) testing the adequacy of the model. Once estimated, the finalized model could be used to predict the direct costs of the alternative abatement techniques at the dwelling unit level. A similar approach was used in the estimation of the markup ratio.

To begin the four stage iterative process for the regression model development, three variables were selected for initial testing: (1) the quantity of surface deleaded, (2) the average wage rate, and (3) a measure of the material price. The response variable for this portion of the model development phase was per unit direct cost. Attempts were also made for each building component and abatement technique to develop separate regression models for per unit labor costs, per unit material/equipment costs, and the productivity of labor.

The construction of the regression model was facilitated by the use of two statistical procedures, the sequential F test and the partial F test. These tests were used to assess the relative importance of variables added to the structure of the model. The sequential F test is used to test whether the model is made significantly better by the addition of a particular variable, whereas the partial F test is used to test

---

<sup>1</sup> The intercept term is included since the assumption that the response is zero when all explanatory variables are zero is a rather strong and usually unjustified assumption.

whether the whole model is significantly better than a reduced model which includes this particular variable.<sup>1</sup>

Taken in conjunction, they permit the deletion of variables which have negligible impact on direct costs and provide a well defined stopping procedure to insure that the model does not become unwieldy.

New variables continue to be added to the model until the value of the partial and sequential F tests are no longer significant. The coefficients of the explanatory variables ( $\beta_j$ ) are estimated through the use of the method of least squares.<sup>2</sup> The method of least squares was used

---

<sup>1</sup> When the form of the model is given by

$$Y = \beta_0 + \sum_{j=1}^m \beta_j X_j + e,$$

the sequential F test will tell if

$$Y = \beta_0 + \sum_{j=1}^t \beta_j X_j + e,$$

is significantly better than

$$Y = \beta_0 + \sum_{j=1}^{t-1} \beta_j X_j + e,$$

whereas the partial F test will tell if

$$Y = \beta_0 + \sum_{j=1}^m \beta_j X_j + e,$$

is significantly better than

$$Y = \beta_0 + \sum_{j=1}^{t-1} \beta_j X_j + e,$$

where  $m \geq t > 1$ .

<sup>2</sup> The method of least squares provides a methodology whereby the sum of the squared difference of the observed and predicted values of the n experimental observations

(cont. on next page)



because the estimates it provides possess several highly desirable statistical attributes.<sup>1</sup> The finalized model is assessed for adequacy through the use of a graphical technique<sup>2</sup> which plots the standardized residuals<sup>3</sup> under the assumption that they are independent normally distributed random variables. This test for adequacy is of great importance since, if the standardized residuals are not independent normally distributed random variables, it is not possible to perform either the sequential or partial F test as an aid in determining when to stop adding variables.<sup>4</sup>

A second test used involved correlation techniques.<sup>5</sup> These techniques describe the linear statistical relationship between two normally distributed random variables. As such they provide a tool for identifying potential sources of multicollinearity, a situation that arises when one or more of the explanatory variables provide essentially the same information. Multicollinearity is undesirable since it reduces the precision of the estimates of the  $\beta_j$ . The correlation coefficient takes on values between  $\pm 1$ . Values close to  $\pm 1$  indicate a high degree of positive or

---

(Continued from previous page.)

$$\sum_{i=1}^n (Y_i - \hat{Y}_i)^2 \quad \text{is minimized,}$$

where  $Y_i$  = the experimental value of the observations, and

$\hat{Y}_i$  = the predicted value of the observation.

- <sup>1</sup> Least squares estimates are both linear combinations of the experimental observations,  $Y_i$ , and minimum variance unbiased estimators of the  $\beta_j$ . Furthermore, they exhibit normality whenever the  $Y_i$  are normally distributed.
- <sup>2</sup> This graphical technique is sometimes referred to as a probability plot.
- <sup>3</sup> The standardized residuals are equal to the residuals (the difference between the observed and predicted values) divided by the standard deviation of the predicted values (a measure of dispersion between the observed and predicted values).
- <sup>4</sup> This as well as other consequences are outlined in N. R. Draper and H. Smith, Applied Regression Analysis, John Wiley and Sons, Inc., 1966, p. 59.
- <sup>5</sup> David Hogben, Sally T. Peavy, and Ruth N. Varner, OMNITAB II User's Reference Manual, pp. 155-162.

negative correlation respectively.<sup>1</sup> A value of 0 indicates that the two variables are uncorrelated. When explanatory variables were found to be highly correlated at the 95 percent confidence level, they were either transformed or deleted from the analysis to prevent the problems for estimation caused by multicollinearity. Also provided in the standard OMNITAB II "CORRELATION" command output is the significance level of a quadratic fit over a linear fit. For example, it would be useful to know where the per unit direct costs for each abatement technique "bottom out." One factor which is likely to be quadratic is job size. Denoting job size as  $Q$  and assuming a quadratic model, we would then expect the sign of  $Q$  to be negative and the sign of  $Q^2$  to be positive. Under the assumption of a quadratic model, the value of  $Q$  which minimizes direct cost could thus be solved through differentiation. Unfortunately, the output from the OMNITAB II "CORRELATION" command did not support the hypothesis that a quadratic model is more appropriate than a linear model. This implies that costs rise or fall at a constant rate as the job size changes.<sup>2</sup>

### C.3 PARAMETER ESTIMATES OF THE EHEP COST MODELS<sup>3</sup>

In Phase II of EHEP, data was collected on six techniques for covering the LBP on walls. Four methods of paint removal on doors and frames, windows and frames, and baseboards were also tested. In this section we shall present the results of our cost analysis for these techniques. The results of our cost analysis for finish painting, component replacement, and contractor markup are also presented. The section concludes with a discussion of how dwelling units may be grouped into contract packages to minimize the expected bid price.

For each technique a table is presented which tabulates the weighting factors (measured effects) associated with the key factors. Combining the values of the weighting factors with those of the key factors permits abatement technique cost to be predicted. The row entries in

---

<sup>1</sup> Positive correlation means that the values of the two variables move in the same direction; negative correlation means that they move in opposite directions.

<sup>2</sup> Because of this linear relationship it was necessary to specify boundary values for each key factor. Note that the use of boundary values is not necessarily a weakness of the Phase II EHEP cost models. Regardless of the form of the model, its use should be restricted to those regions over which the assumptions upon which it is based are valid. In view of the fact that the cost models discussed in the next section were calibrated at the level of the individual dwelling unit, the boundary values presented in Section D.2 seem quite reasonable.

<sup>3</sup> For an excellent discussion of the general topic of cost functions see Gerald L. Musgrave and Robert H. Rasche, "Estimation of Cost Functions," The Engineering Economist, Volume 22, Number 3, Spring 1977.

Tables C.3 through C.18 present our numerical estimates of the amount by which per unit direct costs will change given a unit change in the key factor. If the change in the key factor is more or less than a unit change, the quantitative impact on per unit direct cost will be the product of the row entry in the table (the weighting factor) times the amount of the change in the key factor. For example, one key factor, price per sheet, is measured in dollars. The weighting factor associated with this key factor may be 0.5. This would mean that a one dollar increase in the sheet price would result in a \$0.50 increase in unit per direct cost. A \$.60 decrease in the sheet price would result in a \$0.30 decrease ( $= 0.50 \times 0.60$ ) in direct cost per unit. The format of the table for computing contractor markup (Table C.19) is identical to that of the other tables with the exception that the weighting factors show the quantitative impact on percent markup rather than per unit direct costs.

### C.3.1 KEY FACTOR IMPACTS ON DIRECT COSTS

In this subsection we shall first tabulate the results of the analysis of the direct cost data for the six techniques for abating the LBP hazard on walls. Next we shall tabulate the results of our analysis of the direct costs of paint removal for each of the four techniques tested in Phase II of EHEP. The data analysis on component replacement collected in Phase I of EHEP will then be summarized. The analyses of finish painting costs for walls, ceilings and trim will then be presented.

In each table which follows, the numerical row entries are statistical measurements of the impact on direct cost, material cost, or output per hour of a unit change in a key factor. Multiplying the weighting factor times the value of the key factor and summing yields the direct cost, material cost, or output per hour. Summary statistics which show the explanatory power of each model are presented in Table C.19.

In addition to the weighting factors, the t statistic associated with each parameter estimate (weighting factor) is included in each of the cost models presented in Tables C.3 through C.18. The value of the t statistic is shown within parentheses to distinguish it from the weighting factor. For those tables where more than one model is presented (Table C.12 for example), the number of degrees of freedom is shown immediately below the name of the cost model. For example, in Table C.12  $v = 4$  indicates that the t statistics for the infra-red heating device/door and window model have four degrees of freedom.

Percentiles of the t distribution for selected degrees of freedom are given in Table C.20 so that the level of significance associated with each parameter estimate presented in Tables C.3 through C.18 can easily be determined. For example, comparing the t statistics which appear in Table C.3 to the  $T_{0.975}$  value with eight degrees of freedom

in Table C.20 reveals that all parameter estimates are significant at the 5 percent level. Note that the  $t_{0.975}$  column is used to test significance at the 5 percent level. Similarly the  $t_{0.95}$  column is used to test significance at the 10 percent level, and the  $t_{0.90}$  column is used to test significance at the 20 percent level. In each case, to test significance at the  $\epsilon$  percent level the percentile of the  $t$  distribution examined is equal to  $1 - \epsilon/2$ . This is due to the fact that we are performing a two-tailed test.

TABLE C.3

THE KEY FACTORS DETERMINING DIRECT COST  
PER SQUARE FOOT OF GYPSUM WALLBOARD

| Key Factors                       |           |  |                                |   |  |
|-----------------------------------|-----------|--|--------------------------------|---|--|
|                                   | Intercept | Reciprocal<br>of Net<br>Square Feet <sup>b</sup> | Average<br>Hourly<br>Wage Rate | Price Per<br>4' x 8'<br>Sheet of<br>Gypsum<br>Wallboard | Dummy<br>Variable<br>For Pan-<br>try Work <sup>c</sup> |
| Weighting<br>Factors <sup>a</sup> | -1.7700   | 306.5874   | 0.0620                         | 0.5009  | 0.2740   |
| $t_8$                             | (-3.32)   | (2.62)   | (3.23)                         | (4.02)  | (3.07)   |

<sup>a</sup> The numerical row entries are statistical measurements of the impact on direct cost per square foot (in dollars) of a unit change in a key factor. Multiplying the weighting factor times the value of the key factor and summing yields the direct cost per square foot.

<sup>b</sup> Net square feet is the area measurement of the amount of gross wall area minus the areas not covered by gypsum wallboard, e.g., door openings, window openings, and wall areas covered by cabinets.

<sup>c</sup> This variable takes on a value of 1 if pantry repair work was involved, 0 otherwise. This condition, although specific to the dwelling units in Boston, must be accounted for in order to prevent biases from entering into the other measured effects.

TABLE C.4

THE KEY FACTORS DETERMINING DIRECT COST  
PER SQUARE FOOT OF PLYWOOD PANELING

|                                  |         | Key Factors        |                                |  |  |  |
|----------------------------------|---------|--------------------|--------------------------------|--|--|--|
|                                  |         | Net Square<br>Feet | Average<br>Hourly<br>Wage Rate | Material<br>Cost per<br>Square<br>Foot | Dummy for<br>Poor Man-<br>agement <sup>b</sup> | Dummy for<br>Unfamili-<br>arity <sup>b</sup> |
| Intercept                        |         |                    |                                |  |  |  |
| Weighting<br>Factor <sup>a</sup> | -0.4081 | 0.00054            | 0.0748                         | 1.2602                                 | 0.3579   | 0.1300                                       |
| t <sub>8</sub>                   | (-0.99) | (1.47)             | (3.76)                         | (2.43)                                 | (3.55)   | (1.64)                                       |

<sup>a</sup> The numerical row entries are statistical measurements of the impact on direct cost per square foot (in dollars) of a unit change in a key factor. Multiplying the weighting factor times the value of the key factor and summing yields the direct cost per square foot.

<sup>b</sup> The dummy variables take on a value of 1 if the statement is true and 0 if the statement is false.

TABLE C.5

THE KEY FACTORS DETERMINING MATERIAL COST  
PER SQUARE FOOT OF PLYWOOD PANELING

|                                   | Key Factors     |                             |  |
|-----------------------------------|-----------------|-----------------------------|--|
|                                   | Price per Sheet | Average Hourly<br>Wage Rate | Poor Substrate<br>Condition <sup>b</sup> |
| Weighting<br>Factors <sup>a</sup> | 0.07995         | -0.0231                     | 0.0829                                   |
| t <sub>11</sub>                   | (7.08)          | (-2.50)                     | (2.67)                                   |

<sup>a</sup> The numerical row entries are statistical measurements of the impact on material cost per square foot (in dollars) of a unit change in a key factor. Multiplying the weighting factor times the value of the key factor and summing yields the material cost per square foot.

<sup>b</sup> The dummy variables take on a value of 1 if the statement is true and 0 if the statement is false.

TABLE C.6

THE KEY FACTORS DETERMINING DIRECT COST PER SQUARE  
FOOT OF CEMENTITIOUS COATING AND VENEER PLASTER

|                                  | Key Factors |                         |                                |                                     |   |  |
|----------------------------------|-------------|-------------------------|--------------------------------|-------------------------------------|---|--|
|                                  | Intercept   | Gross<br>Square<br>Feet | Average<br>Hourly<br>Wage Rate | Material<br>Cost per<br>Square Foot | Wallpaper<br>Stripping<br>Required <sup>b</sup> | Veneer<br>Plaster<br>Used <sup>b</sup> |
| Weighting<br>Factor <sup>a</sup> | -0.8817     | -0.0004                 | 0.1154                         | 3.8636                              | 0.1416  | 0.2066                                 |
| t <sub>14</sub>                  | (-2.156)    | (-1.41)                 | (5.02)                         | (10.92)                             | (2.52)  | (3.99)                                 |

TABLE C.7

THE KEY FACTORS DETERMINING MATERIAL COST PER SQUARE  
FOOT OF CEMENTITIOUS COATING AND VENEER PLASTER

|                                  | Key Factors |  |   |  |   |
|----------------------------------|-------------|--|---|--|---|
|                                  | Intercept   | Ratio of<br>Net-to-<br>Gross<br>Square<br>Feet | (Doors & Windows) <sup>2</sup><br>Divided by Gross<br>Square Feet | Veneer<br>Plaster<br>Used <sup>b</sup> | Poor<br>Substrate<br>Condition <sup>b</sup> |
| Weighting<br>Factor <sup>a</sup> | -0.5002     | 0.6872   | 1.3296  | -0.0847                                | 0.1741                                      |
| t <sub>15</sub>                  | (-2.26)     | (2.72)   | (2.31)  | (-2.54)                                | (4.97)                                      |

<sup>a</sup> The numerical row entries are statistical measurements of the impact on direct cost (material cost) per square foot (in dollars) of a unit change in a key factor. Multiplying the weighting factor times the value of the key factor and summing yields the direct cost (material cost) per square foot.

<sup>b</sup> The dummy variables take on a value of 1 if the statement is true and 0 if the statement is false.

TABLE C.8

THE KEY FACTORS DETERMINING THE PRODUCTIVITY OF LABOR  
IN THE INSTALLATION OF VINYL-COATED FABRIC

|                                  | Key Factors |                       |   |                                   |  |
|----------------------------------|-------------|-----------------------|---|-----------------------------------|--|
|                                  | Intercept   | Net<br>Square<br>Feet | Ratio of<br>Net-to-<br>Gross<br>Square Feet | Average<br>Hourly<br>Wage<br>Rate | Percent of<br>Wall Area<br>Wainscotted |
| Weighting<br>Factor <sup>a</sup> | -25.2456    | 0.0276                | 22.0745                                     | 1.2933                            | -24.8364                               |
| t <sub>3</sub>                   | (-1.21)     | (2.32)                | (1.31)                                      | (2.07)                            | (-3.78)                                |

<sup>a</sup> The numerical row estimates are statistical measurements of the impact on productivity of a unit change in a key factor. Multiplying the weighting factor times the value of the key factor and summing yields a productivity estimate for a particular dwelling unit.

TABLE C.9

THE KEY FACTORS DETERMINING MATERIAL COST  
PER SQUARE FOOT OF VINYL-COATED FABRIC

|                                  | Key Factors   |  |
|----------------------------------|---|--|
|                                  | Price per Square<br>Yard of Vinyl-<br>Coated Fabric | Percent of<br>Wall Area<br>Wainscotted |
| Weighting<br>Factor <sup>a</sup> | 0.0958  | 0.5447                                 |
| t <sub>6</sub>                   | (9.32)  | (2.05)                                 |

<sup>a</sup> The numerical row estimates are statistical measurements of the impact on material cost per square foot (in dollars) of a unit change in a key factor. Multiplying the weighting factor times the value of the key factor and summing yields the material cost per square foot.



TABLE C.10

THE KEY FACTORS DETERMINING THE PRODUCTIVITY OF LABOR  
IN THE INSTALLATION OF CEMENT-COATED FIBERGLASS

| Key Factors                      |           |   |  |   |                       |
|----------------------------------|-----------|---|--|---|-----------------------|
|                                  | Intercept | Ratio of<br>Net-to-<br>Gross<br>Square Feet | Percent of<br>Wall Area<br>Wainscotted | Poor<br>Substrate<br>Condition <sup>b</sup> | Occupied <sup>b</sup> |
| Weighting<br>Factor <sup>a</sup> | 43.5809   | -33.6107                                    | -45.5105                               | -3.4202                                     | 9.0642                |
| t <sub>4</sub>                   | (4.37)    | (-2.59)                                     | (-3.10)                                | (-1.22)                                     | (2.11)                |

<sup>a</sup> The numerical row entries are statistical measurements of the impact on productivity of a unit change in a key factor. Multiplying the weighting factor times the value of the key factor and summing yields a productivity estimate for a particular dwelling unit.

<sup>b</sup> The dummy variables take on a value of 1 if the statement is true and 0 if the statement is false.

TABLE C.11

THE KEY FACTORS DETERMINING MATERIAL COST PER  
 SQUARE FOOT OF CEMENT-COATED FIBERGLASS

| Key Factors                      |                                      |                    |
|----------------------------------|--------------------------------------|--------------------|
|                                  | Ratio of Net-to-Gross<br>Square Feet | Average Labor Cost |
| Weighting<br>Factor <sup>a</sup> | 0.5600                               | 1.0900             |
| t <sub>7</sub>                   | (2.90)                               | (3.99)             |

<sup>a</sup> The numerical row entries are statistical measurements of the impact on material cost per square foot (in dollars) of a unit change in a key factor. Multiplying the weighting factor times the value of the key factor and summing yields the material cost per square foot.

<sup>b</sup> The dummy variables take on a value of 1 if the statement is true and 0 if the statement is false.

TABLE C.12

THE KEY FACTORS DETERMINING LABOR COST PER LINEAR  
FOOT USING THE INFRA-RED HEATING DEVICE

| Key Factors                      |                                   |                         |                                   |                                     |
|----------------------------------|-----------------------------------|-------------------------|-----------------------------------|-------------------------------------|
| Windows or Doors<br>v = 4        |                                   |                         | Baseboard Trim<br>v = 7           |                                     |
|                                  | Average<br>Hourly<br>Wage<br>Rate | XRF Time<br>Linear Feet | Average<br>Hourly<br>Wage<br>Rate | Dummy for<br>Infra-Red <sup>b</sup> |
| Weighting<br>Factor <sup>a</sup> | 0.2903                            | -0.0007                 | 0.1354                            | -0.4913                             |
| t                                | (14.06)                           | (-2.46)                 | (4.91)                            | (-1.16)                             |

<sup>a</sup> The numerical row entries are statistical measurements of the impact on labor cost per linear foot (in dollars) of a unit change in a key factor. Multiplying the weighting factor times the value of the key factor and summing yields a cost estimate of the labor cost per linear foot.

<sup>b</sup> This key factor takes on a value of 1 if the labor costs of the infra-red heating device are being analyzed and takes on a value of 0 if solvent strip labor costs are being analyzed. See Table C.13.

TABLE C.13

THE KEY FACTORS DETERMINING LABOR COST PER LINEAR  
FOOT USING SOLVENT-BASED PAINT REMOVER

| Key Factors                      |                                   |                         |                                   |                                     |         |
|----------------------------------|-----------------------------------|-------------------------|-----------------------------------|-------------------------------------|---------|
| Windows or Doors<br>v = 13       |                                   |                         | Baseboard Trim<br>V = 7           |                                     |         |
| Intercept                        | Average<br>Hourly<br>Wage<br>Rate | XRF Time<br>Linear Feet | Average<br>Hourly<br>Wage<br>Rate | Dummy for<br>Infra-Red <sup>b</sup> |         |
| Weighting<br>Factor <sup>a</sup> | -1.3499                           | 0.5727                  | -0.0013                           | 0.1354                              | -0.4913 |
| t                                | (-1.54)                           | (6.53)                  | (-2.63)                           | (4.91)                              | (-1.16) |

<sup>a</sup> The numerical row entries are statistical measurements of the impact on labor cost per linear foot (in dollars) of a unit change in a key factor. Multiplying the weighting factor times the value of the key factor and summing yields a cost estimate of the labor cost per linear foot.

<sup>b</sup> This key factor takes on a value of 1 if the labor costs of the infra-red heating device are being analyzed and takes on a value of 0 if solvent strip labor costs are being analyzed. See Table C.12

TABLE C.14

THE KEY FACTORS DETERMINING DIRECT COST PER LINEAR FOOT  
OF PAINT REMOVAL USING THE ELECTRIC HEAT GUN

|                                  |         | Key Factors                |   |                         |   |        |
|----------------------------------|---------|----------------------------|---|-------------------------|---|--------|
|                                  |         | Windows or Doors<br>v = 14 |   | Baseboard Trim<br>v = 5 |   |        |
|                                  |         | Average                    | Dummy for                                       | Average                 | Dummy for                                       |        |
|                                  |         | Hourly<br>Wage<br>Rate     | Non-Wood<br>Working<br>Contractors <sup>b</sup> | Hourly<br>Wage<br>Rate  | Non-Wood<br>Working<br>Contractors <sup>b</sup> |        |
|                                  |         | Linear<br>Feet             | Dummy<br>for<br>Doors <sup>b</sup>              | Linear<br>Feet          | Linear<br>Feet                                  |        |
| Weighting<br>Factor <sup>a</sup> | 0.2775  | -0.00861                   | 1.8941  | 0.1372                  | -0.0073   | 0.5625 |
| t                                | (11.31) | (-2.34)                    | (11.96)   | (7.00)                  | (-3.98)   | (7.41) |

<sup>a</sup> The numerical row entries are statistical measurements of the key impact on direct cost per linear foot (in dollars) of a unit change in a key factor. The sum of the products of row entries times the observed values of the key factors yields an estimate of the direct cost per linear foot.

<sup>b</sup> The dummy variables take on a value of 1 if the statement is true and 0 if the statement is false.

TABLE C.15

THE KEY FACTORS DETERMINING DIRECT COST PER LINEAR FOOT  
OF PAINT REMOVAL USING THE HAND SCRAPING METHOD

| Key Factors                      |                  |                                   |                                   |                  |
|----------------------------------|------------------|-----------------------------------|-----------------------------------|------------------|
| Windows or Doors<br>v = 9        |                  |                                   | Baseboard Trim<br>v = 4           |                  |
| Intercept                        | Linear<br>Feet   | Average<br>Hourly<br>Wage<br>Rate | Average<br>Hourly<br>Wage<br>Rate |                  |
| Weighting<br>Factor <sup>a</sup> | 0.9468<br>(1.14) | -0.0213<br>(-1.38)                | 0.3262<br>(5.29)                  | 0.1146<br>(5.55) |

<sup>a</sup> The numerical row entries are statistical measurements of the impact on direct cost per linear foot (in dollars) of a unit change in a key factor. Multiplying the weighting factor times the value of the key factor and summing yields an estimate of direct cost per linear foot.

TABLE C.16

THE KEY FACTORS DETERMINING DIRECT COST  
PER UNIT OF COMPONENT REPLACEMENT

|                  |        | Key Factors              |            |                          |             |   |   |
|------------------|--------|--------------------------|------------|--------------------------|-------------|---|---|
|                  |        | Doors                    |            | Door Frames              |             | Windows & Frames  |   |
|                  |        | v = 30                   |            | v = 5                    |             | Average Labor Cost v = 3<br>Average Material Cost v = 4 |   |
| Weighting Factor | t      | Average Hourly Wage Rate | Door Price | Average Hourly Wage Rate | Frame Price | Average Hourly Wage Rate                                | Dummy for Double Hung Window Purchase Price |
| 95.2023          | (4.42) | -4.5476                  | 0.7604     | 5.702                    | 1.699       | 6.740   | 31.516                                      |
|                  |        | (-1.91)                  | (7.92)     | (1.63)                   | (1.68)      | (5.19)  | (1.90)                                      |
|                  |        |                          |            |                          |             |   | 1.1016                                      |
|                  |        |                          |            |                          |             |   | (32.76)                                     |

<sup>a</sup> The numerical row entries are statistical measurements of the impact on direct cost per unit (i.e., per door frame, or per window and frame) of a unit change in a key factor. Multiplying the weighting factor times the value of the key factor and summing yields an estimate of the direct cost per unit of replacement.

<sup>b</sup> Takes on a value of 1 for double hung windows; is 0 otherwise.

TABLE C.17

THE KEY FACTORS DETERMINING THE DIRECT COST PER  
 SQUARE FOOT OF PAINTING<sup>a</sup> WALLS AND CEILINGS

|                                  | Key Factors                     |                                |                           |  |
|----------------------------------|---------------------------------|--------------------------------|---------------------------|--|
|                                  | Gross<br>Square Feet<br>Painted | Average<br>Hourly<br>Wage Rate | Paint Price<br>Per Gallon | Ratio of Net-<br>to-Gross<br>Square Feet |
| Weighting<br>Factor <sup>b</sup> | -0.000296                       | 0.0106                         | 0.0257                    | 0.1736                                   |
| t <sub>63</sub>                  | (-6.73)                         | (2.13)                         | (2.62)                    | (1.78)                                   |

<sup>a</sup> A primer coat and finish coat.

<sup>b</sup> The numerical row entries are statistical measurements of the impact on direct cost per square foot (in dollars) of a unit change in a key factor. The sum of the products of the row entries times the observed values of the key factors yields an estimate of the direct cost per square foot.



TABLE C.18

THE KEY FACTORS DETERMINING DIRECT COST  
PER UNIT OF PAINTING TRIM

|                                  |                 | Key Factors            |                        |                        |                          |                        |                          |
|----------------------------------|-----------------|------------------------|------------------------|------------------------|--------------------------|------------------------|--------------------------|
|                                  |                 | Doors and Frames       |                        | Windows and Frames     |                          | Baseboard              |                          |
| Weighting<br>Factor <sup>a</sup> | t <sub>22</sub> | Average                | Number                 | Average                | Number                   | Average                | Number                   |
|                                  |                 | Hourly<br>Wage<br>Rate | Doors<br>and<br>Frames | Hourly<br>Wage<br>Rate | Windows<br>and<br>Frames | Hourly<br>Wage<br>Rate | Windows<br>and<br>Frames |
|                                  |                 | Paint<br>Price         | Paint<br>Price         | Paint<br>Price         | Paint<br>Price           | Paint<br>Price         | Paint<br>Price           |
| 0.7517                           |                 | 0.9343                 | -0.8776                | 2.5942                 | 1.5865                   | 0.0388                 |                          |
| (3.51)                           |                 | (3.58)                 | (-3.01)                | (6.05)                 | (2.80)                   | (-6.12)                | (7.59)                   |

<sup>a</sup> The numerical row entries are statistical measurements of the impact on per unit direct cost (in dollars) of a unit change in a key factor. Multiplying the weighting factor times the value of the key factor and summing yields an estimate of per unit painting cost for that trim component.

TABLE C.19

## EXPLANATORY POWER OF EHEP PHASE II COST MODELS

| Model                                      | R <sup>2</sup> | Table |
|--|----------------|-------|
| Gypsum Wallboard                           | 0.88           | C.3   |
| Plywood Paneling                           |                |       |
| Direct Cost                                | 0.91           | C.4   |
| Material Cost                              | 0.96           | C.5   |
| Cementitious Coating<br>and Veneer Plaster |                |       |
| Direct Cost                                | 0.91           | C.6   |
| Material Cost                              | 0.66           | C.7   |
| Vinyl-Coated Fabric                        |                |       |
| Productivity                               | 0.88           | C.8   |
| Material Cost                              | 0.96           | C.9   |
| Cement-Coated Fiberglass                   |                |       |
| Productivity                               | 0.80           | C.10  |
| Material Cost                              | 0.86           | C.11  |
| Infra-Red Heating Device                   |                |       |
| Windows and Doors                          | 0.95           | C.12  |
| Baseboards                                 | 0.79           | C.12  |
| Solvent-Based Paint Remover                |                |       |
| Windows and Doors                          | 0.85           | C.13  |
| Baseboards                                 | 0.79           | C.13  |
| Heat Gun                                   |                |       |
| Windows and Doors                          | 0.92           | C.14  |
| Baseboards                                 | 0.97           | C.14  |
| Hand Scraping                              | 0.88           | C.15  |
| Component Replacement                      |                |       |
| Door                                       | 0.80           | C.16  |
| Frames                                     | 0.96           | C.16  |
| Windows and Frames                         | 0.93           | C.16  |
| Painting                                   |                |       |
| Walls                                      | 0.89           | C.17  |
| Trim                                       |                |       |
| Doors and Frames                           | 0.90           | C.18  |
| Windows and Frames                         | 0.91           | C.18  |

TABLE C.20

PERCENTILES OF THE  $t$  DISTRIBUTION FOR SELECTED DEGREES OF FREEDOM<sup>a</sup>

| Degrees of<br>Freedom | Percentiles |            |            |            |             |
|-----------------------|-------------|------------|------------|------------|-------------|
|                       | $t_{0.70}$  | $t_{0.80}$ | $t_{0.90}$ | $t_{0.95}$ | $t_{0.975}$ |
| 3                     | 0.584       | 0.978      | 1.638      | 2.353      | 3.182       |
| 4                     | 0.569       | 0.941      | 1.533      | 2.132      | 2.776       |
| 5                     | 0.559       | 0.920      | 1.476      | 2.015      | 2.571       |
| 6                     | 0.553       | 0.906      | 1.440      | 1.943      | 2.447       |
| 7                     | 0.5439      | 0.896      | 1.415      | 1.895      | 2.365       |
| 8                     | 0.546       | 0.889      | 1.397      | 1.860      | 2.306       |
| 9                     | 0.543       | 0.883      | 1.383      | 1.833      | 2.262       |
| 11                    | 0.540       | 0.876      | 1.363      | 1.796      | 2.201       |
| 13                    | 0.538       | 0.870      | 1.350      | 1.771      | 2.160       |
| 14                    | 0.537       | 0.868      | 1.345      | 1.761      | 2.145       |
| 15                    | 0.536       | 0.866      | 1.341      | 1.753      | 2.131       |
| 22                    | 0.532       | 0.858      | 1.321      | 1.717      | 2.074       |
| 30                    | 0.530       | 0.854      | 1.310      | 1.697      | 2.042       |
| 60                    | 0.527       | 0.848      | 1.296      | 1.671      | 2.000       |

<sup>a</sup> J. Johnston, Econometric Methods, Second Edition, McGraw-Hill Book Company, New York, 1972, p. 426.

C.3.2 KEY FACTOR IMPACTS ON CONTRACTOR MARKUP

In this subsection we shall first discuss the analysis of the data on contractor markup. From Table C.21 it can be seen that the expected contract markup is affected by the number of net square feet in the contract and the number of linear feet of trim requiring paint removal. Further examination of the table indicates that contractors tend to give markup reductions on those products with which they are most familiar (e.g., gypsum wallboard and plywood paneling). In our treatment of direct costs, our emphasis was on being able to identify that technique which minimized direct costs for a given dwelling unit. We saw that changing the values of the key factors could result in a different technique being chosen as the least costly. (Information on exactly how this is done is given in Appendix E.) This indicates that some consideration should be given with regard to the way in which dwelling units are grouped into contract packages. Basic guidelines are given in Appendix E, but for those decision makers faced with deleading a large number of dwelling units additional information is called for. Although the method discussed in the following paragraphs could be carried out by hand, it is most easily accomplished by using the time-sharing program presented in Appendix F.

TABLE C.21  
KEY FACTORS DETERMINING MARKUP<sup>a</sup>

| Key Factors                      |           |                                      |                               |  |
|----------------------------------|-----------|--------------------------------------|-------------------------------|--|
|                                  | Intercept | Hundreds<br>of Net<br>Square<br>Feet | Hundreds<br>of Linear<br>Feet | Fraction in<br>Gypsum Board<br>or Plywood <sup>c</sup> |
| Weighting<br>Factor <sup>b</sup> | 1.2972    | -0.0079                              | 0.0520                        | -0.2144  |
| t <sub>11</sub>                  | (18.55)   | (-2.01)                              | (3.45)                        | (-2.82)  |

<sup>a</sup> The R<sup>2</sup> for this model is 0.77.

<sup>b</sup> The numerical row entries are statistical measurements of the impact on the markup ratio of a unit change in each of the key factors. Multiplying the weighting factor times the value of a key factor in a particular contract and summing these values yields an estimate of the markup ratio for that contract.

<sup>c</sup> Net wall area done using gypsum wallboard or plywood paneling divided by total net wall area.

The first step in grouping the dwelling units into contract packages is to establish a basic data matrix. This matrix identifies the dwelling unit being dealed (the row of the matrix corresponds to the dwelling unit number), the total direct cost of dealeading that unit, the number of net square feet of wall area, the number of linear feet of trim requiring paint removal, and the net square feet of wall area over which gypsum wallboard or plywood paneling will be applied in the dwelling unit. Table C.22 shows the format for the basic data matrix.

TABLE C.22

BASIC DATA MATRIX

| Dwelling Unit # | Direct Cost | Net Square Feet | Linear Feet | Net Square Feet in Gypsum Wallboard or Plywood Paneling |
|-----------------|-------------|-----------------|-------------|---|
| 1               | $D_1$       | $N_1$           | $L_1$       | $GP_1$  |
| 2               | $D_2$       | $N_2$           | $L_2$       | $GP_2$  |
| ...             | ...         | ...             | ...         | ...   |
| N               | $D_N$       | $N_N$           | $L_N$       | $GP_N$  |

Using the data in Table C.22, it then becomes possible to study the differential markups. That is, how much does the markup ratio change (either rise or fall) by grouping two arbitrary dwelling units  $i$  and  $j$  together. The basic question here is can bid price be lowered by grouping dwelling units together? Suppose dwelling unit  $i$  has a direct cost of  $D_i$  and a markup ratio of  $M_i$  and dwelling unit  $j$  has a direct cost  $D_j$  and a markup ratio of  $M_j$ . Now suppose dwelling unit  $i$  were to be grouped with dwelling unit  $j$ , would the bid price then be lower? To see if this criterion is met, we shall examine the following relation:

$$D_1 (b_0 + M'_1) + D_2 (b_0 + M'_2) \geq (D_1 + D_2) (b_0 + M'_1 + M'_2)$$

where  $b_0$  = the intercept term in Table C.19; and

$M'_k$  = the sum of the products of the weighting factors times the value of the key factors.

Upon cancellation we get

$$D_1 M'_2 + D_2 M'_1 \leq 0$$

The above relationship is particularly useful. The left hand side of the first inequality is the total cost of letting two single dwelling unit contracts whereas the right hand side is the total cost if the two units are done as one contract. The second inequality tells us under what condition the cost of grouping the two dwelling units together will be lower than letting two single unit contracts.

If we think of the  $M'$  as markup differentials, we may use them to determine the impact that grouping dwelling unit  $j$  with dwelling unit  $i$  will have on  $i$ 's markup ratio. Let us refer to this impact as  $M_{ij}$ , and define  $M_{ij}$  as:

$$M_{ij} = b_1 N_i + b_2 L_i + b_3 \frac{GP_i}{N_i + N_j} \quad \text{for } i \neq j$$

$$= 9 \quad \text{for } i = j$$

(Setting  $M_{ii} = 9$  is a precautionary measure to avoid pairing a dwelling unit with itself.)

Clearly the  $M_{ij}$  form a matrix of markup differentials which we shall denote as  $M$ , where

$$M = (M_{ij}) \quad 1 \leq i, j \leq N$$

We may now construct a matrix,  $D$ , with the direct cost per dwelling unit along the diagonal and zeros elsewhere. Mathematically

$$D = (D_{ij}) \quad 1 \leq i, j \leq N$$

$$\text{where } D_{ij} = D_i \quad \text{if } i=j$$

$$= 0 \quad \text{if } i \neq j$$

Postmultiplying  $M$  by  $D$  yields the desired test matrix,  $MD$ , where

$$MD = [(MD)] = D_{ii} M_{ji} \quad 1 \leq i, j \leq N.$$

We now wish to see the impact that grouping an arbitrary dwelling unit,  $k$ , with another dwelling unit,  $i$ , will have on the contract's expected bid price. This impact may be expressed mathematically as:

$$V_{ki} = M_{ik} D_k + M_{ki} D_i.$$

We then wish to see which dwelling unit, when paired with  $k$ , will have the most favorable impact on the expected bid price of the contract. Denote this dwelling unit as  $V_k^* = \min_i (V_{ki})$ .

Once all  $N$  dwelling units have been examined, we will have a set of most favorable impacts:

$$V^* = (V_1^*, V_2^*, \dots, V_N^*).$$

The  $V_k^*$  are then ranked from smallest to largest. We denote this set as

$$V^* = (V_{(1)}^*, V_{(2)}^*, \dots, V_{(N)}^*),$$

and  $V_{(k)}^*$  is the  $k^{\text{th}}$  order statistic of the set  $V^*$ .

Clearly,

$$V_{(1)}^* \leq V_{(2)}^* \leq \dots \leq V_{(N)}^*.$$

Now by starting with  $V_{(1)}^*$ , we can be certain that the dwelling units are paired to insure that the dwelling unit which has the most favorable impact on overall bid price will be selected first. Let the first two dwelling units chosen be denoted as  $J_1$  and  $J_2$ . Through this process we may continue to group the dwelling units together. The end result will be the preliminary contract package assignment. Table C.23 is an example of what such a grouping would look like.

TABLE C.23

PRELIMINARY CONTRACT PACKAGE ASSIGNMENT

| Contract Package # | Dwelling Units in Contract | Contract Direct Cost | Contract Net Square Feet | Contract Linear Feet | Contract Net Square Feet in Gypsum Wall-board and Plywood Paneling |
|--------------------|----------------------------|----------------------|--------------------------|----------------------|--|
| 1                  | $J_1 \quad J_2$            | $D_{J_1} + D_{J_2}$  | $N_{J_1} + N_{J_2}$      | $L_{J_1} + L_{J_2}$  | $GP_{J_1} + GP_{J_2}$  |
| 2                  | $J_3 \quad J_4$            | $D_{J_3} + D_{J_4}$  | $N_{J_3} + N_{J_4}$      | $L_{J_3} + L_{J_4}$  | $GP_{J_3} + GP_{J_4}$  |
| ...                |                            |                      |                          |                      |  |
| K                  | ...                        | ...                  | ...                      | ...                  | ...  |

Notice that Table C.23 is similar to Table C.22. (Table C.22, in addition to providing input data, serves as a map between the contract number and the unit number.)

We now wish to see if grouping any two of the two dwelling unit contracts together into a single four dwelling unit contract will reduce the overall

contract cost. (Note if an odd number of dwelling units were analyzed in the previous step, there will be one single unit contract left over. Therefore the possible contract package sizes are two, three, four or five dwelling units.) To see if contract costs reductions result, we once more examine the markup differential now defined as

$$\begin{aligned} (MC)_{ij} &= b_1 (NC)_i + b_2(LC)_i + b_3 \frac{(GC)_i}{(NC)_i + (NC)_j} & i \neq j \\ &= 9 & i = j \end{aligned}$$

where  $(NC)_i$  = the net square feet in "preliminary" contract  $i$ ;

$(LC)_i$  = the linear feet in "preliminary" contract  $i$ ; and

$(GPC)_i$  = the net square feet of gypsum wallboard and plywood paneling in "preliminary" contract  $i$ .

Once again the  $(MC)_{ij}$  form a matrix of markup differentials which we shall denote as  $MC$ , where

$$MC = ((MC)_{ij}) \quad 1 \leq i, j \leq \frac{N}{2}$$

Similarly we may construct the matrix  $DC$  with the direct cost per "preliminary" contract along the diagonal and zeros elsewhere. Postmultiplying  $MC$  by  $DC$  yields the desired test matrix. We then calculate the the contract cost differential,  $(VC)_{ij}$ , defined as

$$(VC)_{ij} = (MC)_{ij} (DC)_j + (MC)_{ji} (DC)_i.$$

We now wish to see which "preliminary" contract, when paired with  $i$ , will have the most favorable impact on the total contract cost. We denote this contract as  $(VC^*)_i$  where

$$(VC^*)_i = \min_j (VC)_{ij}.$$

We then test to see if  $(VC^*)_i$  is less than zero. If not, then we will not group contract  $i$  with any other contract since the overall cost has not been reduced. All those  $(VC^*)_i$  which were found to be less than zero are then ranked from smallest to largest. Starting with the smallest  $(VC^*)_i$ ,  $(VC^*)_{(1)}$ , we then form a new and final contract package. This process is continued until all contracts have been examined. Suppose the first two contracts chosen were "preliminary" contracts 1 and 3. The final contract would then include all dwelling units in the two "preliminary" contracts. From Table C.23 we would then identify the dwelling unit numbers. The time-sharing program would then refer to Table C.22 to determine all the dwelling unit specific data required to make the final cost calculations.



The last set of calculations is to determine if contract costs can be reduced by substituting gypsum wallboard or plywood paneling in those dwelling units in which another barrier material was found to minimize direct costs. Recall that gypsum wallboard and plywood paneling, due to their familiarity, are subject to markup reductions.

As a first step, we identify the least costly of the two products (gypsum wallboard and plywood paneling). We then subtract from it the direct cost of the barrier material which was found to minimize direct costs in the dwelling unit under study. We shall denote this cost difference as  $\Delta D$ . Next we recompute the markup ratio under the assumption that gypsum wallboard or plywood paneling will be installed in the dwelling unit under study. Denote this new markup ratio as  $M_1$ . We may now calculate the change in the markup ratio (for the entire contract) due to the discount for gypsum wallboard or plywood paneling. If we denote  $M_0$  as the original markup ratio, then  $\Delta M$  is equal to  $M_0$  minus  $M_1$ . If we denote the direct cost of the contract as  $D$ , then the switching criteria is given by the following inequality.

$$\Delta D \cdot M_1 + \Delta M \cdot D \leq 0.$$

If the above inequality is not satisfied then no reduction in overall contract cost can be achieved by switching to gypsum wallboard or plywood paneling. The above test is performed for each dwelling unit. After completion of this test no further reduction in contract package costs can be achieved. Thus the packages assembled in the previous step should reflect both the least costly combination of dwelling units and of abatement techniques.

### C.3.3 METHODS FOR CALCULATING CONFIDENCE INTERVALS ABOUT PREDICTED COSTS

Each of the cost models presented in Sections C.3.1 and C.3.2 combine one or more explanatory variables in order to estimate a response variable (direct cost, material cost, output per hour, or markup). Although these models are best linear unbiased estimators of the desired response variable, they represent point estimates rather than interval estimates. Thus there may be situations in which other abatement techniques may have costs very near to the least costly technique. This would imply that the least costly abatement technique can not be unambiguously identified. In Section D.4 empirical evidence will be presented to show that, on the average, there will be a wide range of costs even if the three least costly techniques for deleading walls and two least costly techniques for deleading trim can be identified. Hence it appears that even though the cost models presented in Sections C.3.1 and C.3.2 produce only point estimates, there should be enough difference in cost between techniques to assume that the least costly technique can be unambiguously identified.

Even though in most cases there will be a wide enough variation in costs between techniques to identify one as least costly, there may be

instances where confidence intervals about each estimated response are desired. The purpose of this section is to illustrate how this may be accomplished. First, we must define precisely what we mean by a confidence interval. The  $100(1 - \epsilon)$  percent confidence interval associated with a particular cost model is defined as

$$C' \hat{\beta} \pm t_{\epsilon/2} \sqrt{C'(X'X)^{-1}C}$$

where

$\hat{\beta}$  = the vector of estimated coefficients (weighting factors);

$C$  = the vector of explanatory variables (key factors);

$\sqrt{C'(X'X)^{-1}C}$  = an estimator of the standard deviation of the predicted value,  $C \hat{\beta}$ ; and

$t_{\epsilon/2}$  = the  $1 - \epsilon/2$  value of the t statistic with  $n - k$  degrees of freedom.<sup>1</sup>

The output of each cost model presented in Sections C.3.1 and C.3.2 is the point estimate  $C' \hat{\beta}$ . Suppose we denote the cost model associated with the least cost point estimate as

$$C'_{(1)} \hat{\beta}_{(1)}$$

and the cost model associated with the second least cost point estimate as

$$C'_{(2)} \hat{\beta}_{(2)}$$

Then the hypothesis which we wish to test<sup>2</sup> is

$$H_0 : C'_{(1)} \hat{\beta}_{(1)} < C'_{(2)} \hat{\beta}_{(2)},$$

the alternative being

$$H_A : C'_{(1)} \hat{\beta}_{(1)} > C'_{(2)} \hat{\beta}_{(2)}.$$

---

<sup>1</sup> The number of degrees of freedom is based on the information used in estimating the cost model, in particular,  $n$  is the number of observations and  $k$  is the number of explanatory variables.

<sup>2</sup> Since the purpose of this section is to illustrate how to fit a confidence interval about the predicted value, no discussion of how the null and alternative hypotheses stated above would be tested will be given. For those readers interested in performing tests of statistical hypotheses, the text by K. A. Brownlee, Statistical Theory and Methodology in Science and Engineering, is recommended.

Notice that  $C'_{(1)}$  need not equal  $C'_{(2)}$  since different cost models use different explanatory variables (key factors). From the definition of the  $100(1 - \epsilon)$  percent confidence interval given above it is apparent that the variance-covariance matrix associated with each cost model,  $s^2 (X'X)^{-1}$ , is needed in order to calculate the desired confidence interval. Fortunately, the variance-covariance matrix associated with each cost model is provided as part of the standard OMNITAB "FIT" output.

Let us now examine how a 90 percent confidence interval may be fitted around the direct cost per square foot estimate for plywood paneling. The variance-covariance matrix for the plywood paneling cost model is given in Table C.24. Note that each of the entries are given in a scientific notation format. For example,  $1.70 -01$  in scientific notation is merely 0.170, similarly  $-6.30 -03$  is merely  $-0.00630$ . Thus the use of scientific notation permits the variance-covariance matrix to be presented in a more simple and compact manner.

Suppose we now wish to fit a confidence interval about the estimate resulting from deleading 537 net square feet of wall area in a dwelling unit. Prior information on wage rates and prices for a four by eight foot sheet of plywood paneling indicate that the average wage rate is \$10.09 per hour and the cost per square foot of plywood

paneling is \$0.45,  $(\frac{14.40}{32})$ . The transpose of the vector of explanatory variables (key factors),  $C'$ , is thus

$$C' = (1, 537, 10.09, 0.45, 0, 0).$$

Similarly, the transpose of the vector of estimated coefficients<sup>1</sup> (weighting factors),  $\hat{\beta}$ , is

$$\hat{\beta}' = (-0.4081, 0.00054, 0.0748, 1.2602, 0.3579, 0.13)$$

The predicted value,  $C'\hat{\beta}$ , which results is

$$C'\hat{\beta} = (-0.4081)(1) + (537)(0.00054) + (10.09)(0.0748) + (0.45)(1.2602) \\ + 0 + 0$$

Simplyfying we have

$$C'\hat{\beta} = 1.20.$$

That is the direct cost of installing plywood paneling is \$1.20 per square foot in this case.

---

<sup>1</sup> The values of the weighting factors are taken from Table C.4.

TABLE C.24  
VARIANCE-COVARIANCE MATRIX FOR PLYWOOD PANELING COST MODEL

| Key Factor      | Intercept | Net Square Feet | Wage Rate | Material Cost | Supervision | Familiarity |
|-----------------|-----------|-----------------|-----------|---------------|-------------|-------------|
| Intercept       | 1.70 -01  | -1.14 -04       | -6.30 -03 | -1.74 -01     | 2.75 -02    | -9.58 -03   |
| Net Square Feet | -1.14 -04 | 1.36 -07        | 2.65 -06  | 8.26 -05      | -2.07 -05   | 1.11 -05    |
| Wage Rate       | -6.30 -03 | 2.65 -06        | 3.95 -04  | 4.58 -03      | -1.01 -03   | 1.68 -04    |
| Material Cost   | -1.74 -01 | 8.26 -05        | 4.58 -03  | 2.68 -01      | 2.85 -02    | 6.26 -03    |
| Supervision     | 2.75 -02  | -2.07 -05       | -1.01 -03 | 2.85 -02      | 1.02 -02    | -7.14 -04   |
| Familiarity     | -9.58 -03 | 1.11 -05        | 1.68 -04  | 6.26 -03      | -7.14 -04   | 6.25 -03    |

We now wish to compute the width of the confidence interval,  $w$ , where

$$w = t_{8,0.95} \sqrt{C' s^2 (X'X)^{-1} C}$$

Obtaining the appropriate value for the  $t$  distribution with eight degrees of freedom from Table C.20 reduces the above statement to

$$w = 1.86 \sqrt{C' s^2 (X'X)^{-1} C}$$

Performing the indicated matrix multiplication,  $C' s^2 (X'X)^{-1} C$ , and taking the square root of the resulting scalar yields

$$\sqrt{C' s^2 (X'X)^{-1} C} = 0.06$$

Thus the width of the confidence interval is 11 cents ( $w = (0.06)(1.86)$ ). The 90 percent confidence interval,  $I_{0.90}$ , about the predicted value for plywood paneling in this case is thus

$$I_{0.90} = (1.09, 1.31) \text{ or}$$

$$I_{0.90} = 1.20 \pm 0.11 = C' \hat{\beta} \pm w.$$

The 90 percent confidence interval, or any other percent confidence interval, associated with any of the other cost models can be calculated in a similar manner. Note however that new confidence interval must be calculated each time the values of the key factor are changed. In addition, some care must be exercised in determining the number of degrees of freedom for the  $t$  distribution and the appropriate percentile column. Due to the number of cost models and the size and complexity of the variance-covariance matrices associated with the cost models, variance-covariance matrices for each cost model will not be included in this report.<sup>1</sup>

---

<sup>1</sup> For those readers who may wish to calculate confidence intervals, copies of the variance-covariance matrices for any cost models presented in this report are available upon written request.

## APPENDIX D

### DISCUSSION OF EHEP PHASE II DATA CHARACTERISTICS AND EMPIRICAL IMPLICATIONS

Section D.1 of this appendix discusses any special data or estimation problems that arose in the statistical analysis of the parameters of the cost models. In Section D.2 the values of the lower and/or upper bounds of the key factors will be detailed in two tables, one for wall techniques and one for trim techniques. If a key factor takes on values less than or greater than a boundary value (depending on the nature of the boundary) the boundary value should be substituted for that value of the key factor. Such occasions should rarely arise. But to avoid producing estimates of costs which are outside of the reliable range of the EHEP Phase II models, it is necessary to make such substitutions. These boundary values have been incorporated into the BASIC Program so that such substitutions are made automatically by the program. Section D.3 addresses the question of whether or not scale economies due to increasing the job size and/or the contract package size exist. Section D.4 presents empirical evidence which supports the assertion that significant dollar savings can be achieved through the use of the EHEP Phase II cost models.

#### D.1 TECHNIQUES FOR DELEADING WALLS AND TRIM

##### D.1.1 PLYWOOD PANELING

In four of the 14 dwelling units in which plywood paneling was installed, relatively high costs per square foot were observed. It was also noted that two firms were each responsible for two of these dwelling units. One firm was primarily a painting contractor. The other firm was observed by the Boeing field staff to exercise almost no supervision over that contract. Thus two dummy variables are included in the plywood model as key factors. The first key factor took on the value of 0 for all dwelling units where the plywood installation was done by the firms that exercised normal supervision. For the firm with inadequate supervision, the key factor took on a value of 1.

As can be seen in Table C.4 inadequate supervision raised that contractor's direct cost per square foot by \$0.36. A similar procedure was followed for the painting contractor. That firm's unfamiliarity with the techniques of installation of plywood paneling raised direct costs per square foot by \$0.13. Although these key factors may be unique to the Boston firms, they do illustrate the importance of adequate management and practical experience.

##### D.1.2 VINYL-COATED FABRIC

Although this product was installed in 11 dwelling units in Phase II of EHEP, only eight of the dwelling units provided statistically reliable observations. In the three dwelling units that were rejected, the

installation of vinyl-coated fabric was done by contractors whose cost reports were considered very unreliable. In two of these cases the contractor used a "profit sharing" arrangement with his workmen. This arrangement precluded the payment of wages to those workmen. Their recorded figures for hours worked are not considered reliable. In the last case the contractor who installed the vinyl-coated fabric was a non-profit institution whose primary goal was training unskilled youth. Their productivity figures are also extremely biased.

#### D.1.3 CEMENT-COATED FIBERGLASS

In Boston nine of the 13 dwelling units treated with this barrier material provided usable cost measurements. As was the case with vinyl-coated fabric, the non-profit contractor, and the contractor who had profit sharing arrangements with his workmen, provided additional but unusable observations.

The ratio of net-to-gross square feet is a key factor which impacts on the productivity of labor in installing cement-coated fiberglass. This key factor was also important in the installation of vinyl-coated fabric. However, this key factor has exactly the opposite quantitative impact on productivity for cement-coated fiberglass than it did in the case of vinyl-coated fabric. For cement-coated fiberglass fewer openings (windows, doors or cupboards) in walls of a given gross square footage have the effect of lowering productivity. The opposite was true for vinyl-coated fabric. Since the installation procedures for these two barrier materials are similar, no ready explanation for this difference comes to mind. The statistical measurements of the differential effects of this key factor are reliable. One speculation for this result is that these results may be reflecting something relating to the ease of the handling of these two materials. The Boeing representatives who handled EHEP contract administration and monitoring made the following comments about cement-coated fiberglass:

Cement-coated fiberglass had imperfections at the edges which resulted in a loss of up to six inches of material on a side causing a need to re-order. Handling and folding during preparation for installation produced flaking of the cement from the fiberglass weave causing noticeable flaws which could not be corrected.<sup>1</sup>

#### D.1.4 SOLVENT-BASED PAINT REMOVER AND INFRA-RED HEATING DEVICE

Since the infra-red heating device was used to remove paint from baseboards in only three dwelling units and the solvent-based paint remover

---

<sup>1</sup> Boeing Aerospace Company, Experimental Hazard Elimination Program Dwelling Unit Report: Phase II, Part II B General Data, for Department of Housing and Urban Development, December, 1976, unpublished, p.15.

was used on baseboards in only six dwelling units, the nine observations were combined into one data set. This combined data set was used to produce parameter estimates for paint removal from baseboards which apply to both the solvent-based paint remover and the infra-red heating device. These results are reported twice, both in Tables C.12 and C.13 under the heading "Baseboard Trim." A model was estimated which included a dummy for infra-red but it was not found to be statistically significant.

#### D.1.5 FINISH PAINTING

The costs of painting walls and ceilings demonstrated a very wide variation in the Boston Phase of EHEP. Four key factors however were able to explain 89 percent of the total variation of the costs of painting walls and ceilings. Increasing the gross square footage to be painted by 100 square feet will cause direct cost per square foot to fall by 3 cents. A dollar an hour increase in the average wage rate raises per square foot costs by 1 cent per square foot while a dollar per gallon increase in the price of paint increases the cost per square foot by 2.6 cents. Lastly an increase in the ratio of net square feet to gross square feet of 0.1 will increase painting cost per square foot by 1.7 cents.

#### D.2 RANGES OVER WHICH THE COST MODELS ARE VALID

In order to minimize the possibility of the cost equations producing spurious estimates of direct costs,<sup>1</sup> it is necessary to place restrictions upon the values that are assigned to the key factors. Since a cost estimating equation will usually contain more than one key factor, it is not possible to solve directly for the minimal or maximal values that the key factors can assume. The possibility of negative forecasts occurring is more likely when the values of the key factors differ substantially from the values taken by the key factors in the Boston data set. Thus we have calculated for each key factor which must be entered into the computer program or in the hand calculations a tolerance interval. A tolerance interval (based upon the Boston data sets) tells you with some known probability that a given proportion of the population will lie within a given interval. Thus by calculating a tolerance interval for each of the key factors and specifying that the key factor may not assume a value greater than or less than the end points of the tolerance interval we defend against the possibility of extreme values (extreme relative to the Boston experience) producing spurious cost estimates. The tolerance intervals used to establish the boundary values in Table D.1 are based on a 90 percent probability that 90 percent of the population of a key factor will lie within the calculated interval.

---

<sup>1</sup> Spurious values of the dependent variable are possible because of the linear form of the estimated equations.



TABLE D.1

## BOUNDARY VALUES OF KEY FACTORS USED TO COMPUTE DIRECT COSTS

| Technique/<br>Key Factor                           | Value of<br>Lower Bound | Value of<br>Upper Bound |
|--|-------------------------|-------------------------|
| <u>Gypsum Wallboard</u>                            |                         |                         |
| Wage Rate  | \$4.88                  | N.A.*                   |
| Sheet Price  | \$1.83                  | N.A.                    |
| <u>Plywood Paneling</u>                            |                         |                         |
| Wage Rate  | \$5.97                  | N.A.                    |
| Gross Square Feet                                  | 282                     | 930                     |
| Sheet Price  | \$6.07                  | N.A.                    |
| Material Cost Per Square<br>Foot                   | \$0.23                  | N.A.                    |
| <u>Cementitious Coating and Veneer<br/>Plaster</u> |                         |                         |
| Wage Rate  | \$6.51                  | N.A.                    |
| Gross Square Feet                                  | 406                     | 770                     |
| <u>Cement-Coated Fiberglass</u>                    |                         |                         |
| Percent Wall Area Wain-<br>scotted                 | 0%                      | 40%                     |
| <u>Vinyl-Coated Fabric</u>                         |                         |                         |
| Wage Rate  | \$4.11                  | N.A.                    |
| Gross Square Feet                                  | N.A.                    | 916                     |
| Price Per Square Yard                              | \$4.46                  | \$5.06                  |
| Percent Wall Area Wain-<br>scotted                 | 0%                      | 40%                     |
| <u>Heat Gun</u>                                    |                         |                         |
| Wage Rate  | \$3.68                  | N.A.                    |
| <u>Hand Scraping</u>                               |                         |                         |
| Wage Rate  | \$3.54                  | N.A.                    |
| <u>Infra-Red</u>                                   |                         |                         |
| Wage Rate  | \$3.61                  | N.A.                    |
| XRF Times Linear Feet of<br>Windows or Doors       | N.A.                    | 1142                    |
| <u>Solvent Strip</u>                               |                         |                         |
| Wage Rate  | \$3.82                  | N.A.                    |
| XRF Times Linear Feet of<br>Windows or Doors       | N.A.                    | 1008                    |

\*Not applicable

### D.3 TREATMENT OF INTRA-UNIT AND INTER-UNIT ECONOMIES OF SCALE

The presence or absence of scale economies is a question of fundamental importance. If scale economies exist, can be identified, and can be taken advantage of, the total costs of lead paint abatement will be reduced. Two potential types of scale economies exist. They are: (1) intra-unit (increasing the number of square feet, linear feet or components in a given dwelling unit) scale economies, and (2) inter-unit (increasing the number of dwelling units in a contract) scale economies. By reference to Section C.3.2 it can be seen that fairly strong intra-unit scale economies exist. In particular, in nine out of the ten abatement techniques analyzed in Phase II of EHEP it was found that increasing job size (the number of square feet, linear feet, or components in a given dwelling unit) caused the per unit direct cost to fall. The question of whether or not inter-unit scale economies exist however, must be approached in a different manner. To answer this question reference will be made to the first phase of EHEP.

In Phase I of EHEP the size of abatement contracts ranged from 1 to 30 dwelling units. With such a wide variation in contract package size it is possible to thoroughly test the impact that increasing the contract package size has on direct costs. The information required to perform this test is presented in Economic Analysis of Experimental Lead Paint Abatement Methods: Phase I.<sup>1</sup> In this report regression equations for direct cost were estimated which included the two types of scale economies.<sup>2</sup>

A close examination of the results of the Phase I cost data analysis, reveals that the coefficient of contract package size<sup>3</sup> is positive and

---

<sup>1</sup> Robert E. Chapman, Economic Analysis of Experimental Lead Paint Abatement Methods: Phase I, National Bureau of Standards, Technical Note 922, September 1976.

<sup>2</sup> It is important to point out that preliminary results from Phase I affected the experimental design of Phase II of EHEP. The formulation of the experimental design was also affected by preliminary results from the Pittsburgh survey. (Although the results of this survey had not been published at the time, information on the approximate number of lead painted wall and trim surfaces were available.) Since the number of dwelling units included in Phase II was limited to around 80 by budgetary constraints, prior information from Phase I and the Pittsburgh survey was of vital importance.

<sup>3</sup> See Tables 4.6, 4.9, and 4.12 on pages 54, 60, and 65 in Robert E. Chapman, Economic Analysis of Experimental Lead Paint Abatement Methods: Phase I.

significant<sup>1</sup> for trim techniques (paint removal methods). On the other hand in five out of the eight wall techniques (barrier materials) the coefficient of contract package size<sup>2</sup> is negative. The presence or absence of scale economies thus depends on the relative strengths of these effects. For example, if a dwelling unit contained 500 square feet of wall area, four doors and frames and six windows and frames, adding another identical dwelling to the contract would increase trim costs by approximately \$9.00 while reducing wall costs by approximately \$4.00. Recall that this is for direct costs and not total costs which include markup. Consequently, based on the Phase I cost experience, although increasing the size of the contract produced some reductions in wall costs more than compensating increases in trim costs are likely to result. Thus it can not be claimed that reductions in direct cost due to larger contract packages exist and are significant. Total costs which include markup can be expected to follow this pattern.

As expected, this phenomena was also observed in Phase II where the presence of trim deleading work strongly affects the markup applied to the entire contract. Thus if only wall abatement were required the best strategy would be to use larger contracts since a potential for economies of scale does exist. Unfortunately, this does not reflect the true nature of the lead paint problem. Dwelling units with hazardous levels of lead paint contain not only hazardous wall areas but substantial amounts of lead painted trim surfaces.<sup>3</sup> In addition, the trim surfaces have higher lead levels which would tend to place more emphasis on their abatement.<sup>4</sup>

Fortunately, the markup equation, presented in Table C.21, reveals that there exists a potential for judiciously grouping dwelling units together into contract packages so that the sum of the bid prices can be minimized. This approach takes into explicit consideration the potential for cost reductions due to increased amounts of wall work and balances it against cost increases due to increased amounts of trim work.

The approach, explained in Section C.3.2, uses an iterative scheme which results in a stable solution in that no cost reductions can be achieved

---

<sup>1</sup> At the 10 percent level.

<sup>2</sup> See Table 4.3 on page 49 in Robert E. Chapman, Economic Analysis of Experiment Lead Paint Abatement Methods: Phase I.

<sup>3</sup> Douglas R. Shier and William G. Hall, Analysis of Housing Data Collected in a Lead-Based Paint Survey in Pittsburgh, Pennsylvania Part I.

<sup>4</sup> Douglas R. Shier and William G. Hall, Analysis of Housing Data Collected in a Lead-Based Paint Survey in Pittsburgh, Pennsylvania Part I.

by moving a dwelling unit from one contract to another. Contract packages of up to five dwelling units are allowed. However, a more rigorous test of the hypothesis that scale economies due to increasing the size of the abatement contract do not exist is now in order. The following experiment was performed. A distribution of hazardous wall and trim surfaces based on the data presented in the Shier-Hall reports and data from EHEP was formulated. A random sample of 50 hypothetical dwelling units was selected from this distribution. These dwelling units were grouped into five preliminary contracts of ten units each. The data on each preliminary contract was then fed into the computer program. Contract package sizes were then recorded and averaged. The average contract package which resulted was 2.2 dwelling units. Obviously contract package sizes of two were the most frequent. Thus it seems likely that any gains due to economies of scale in wall work are more than offset by the presence of trim work. Consequently, it can be asserted that no significant inter-unit scale economies exist.

#### D.4 POTENTIAL SAVINGS RESULTING FROM THE USE OF THE EHEP PHASE II COST MODELS

In the report Guidelines for Cost-Effective Lead Paint Abatement, it was stated that "if the least-cost combination of abatement techniques can be identified and installed, empirical results indicate that savings of approximately \$100 per dwelling unit can be achieved."<sup>1</sup> The purpose of this section is to present those empirical results.

A first means of justifying this figure, and the most probable range of savings from \$80 to \$120, is the assumption that cost estimates would be based on a dwelling unit having 500 square feet of wall area, 3 doors and frames, 5 windows and frames and 50 linear feet of miscellaneous trim requiring deleading. Since assumptions may always be questioned additional empirical evidence has been brought forward to support this claim. In particular, two independent tests were conducted to determine if the \$80 to \$120 figure was supported by existing lead paint abatement cost data.

In the first test a random sample of dwelling units deleading in the Atlanta operation was selected. (Recall that in Atlanta the abatement techniques were assigned on the basis of engineering judgment.) The cost of each abatement technique was then estimated for each dwelling unit. Actual deleading costs were then compared to the estimated costs. Anticipated savings associated with the use of the least-cost technique were then tabulated. In the event that the least-cost technique was the one actually installed no cost savings were attributed to the use of the EHEP procedure. The tabulated cost savings, including those which were zero entries, were then averaged. These findings, based on

---

<sup>1</sup> Robert E. Chapman and Joseph G. Kowalski, Guidelines for Cost-Effective Lead Paint Abatement, page iv.

the Atlanta cost experience, indicate that a direct cost savings of approximately \$110 per dwelling would have resulted if the least-cost abatement technique could have been identified and installed.

In the second test a random sample of the hypothetical dwelling units used in the experiment discussed in Section D.3 was selected. (Recall that in Section D.3 the existence of scale economics was tested.) In this test the expected cost of each technique was estimated. The three least costly wall techniques and the two least costly trim techniques were then identified. Average wall costs and average trim costs were then calculated for each dwelling unit. (Note that these averages are based on the three least costly wall and two least costly trim techniques.) The average savings in direct costs were \$83 with a range from \$43 to \$140. The average savings when markup was included were \$106 with a range from \$53 to \$181.

Both tests support the claim that substantial savings can be achieved through the use of the EHEP procedure. Furthermore, this is true even if some a priori knowledge can be used to reduce by one half the number of abatement techniques under consideration. Given that the second test is both more stringent and produces more conservative levels of savings, a strong argument can be made to claim per dwelling unit savings of between \$80 and \$120.

## APPENDIX E

### METHODOLOGY FOR PERFORMING HAND CALCULATIONS

#### E.1 DESCRIPTION OF METHOD

Given that a program administrator faces the problem of deleading a few dwelling units, the selection of the least-cost wall and/or trim techniques to use in each unit can be accomplished using hand calculations. Four major tasks are required. These tasks are:

- (1) Grouping dwelling units into contract packages;
- (2) Identifying the least-direct-cost wall and/or trim techniques for each unit;
- (3) Computing the markup factor for each contract; and
- (4) Estimating the minimum bid price for each contract.

The computational procedures for each of these tasks are described below:

#### Task 1: Grouping Dwelling Units Into Contract Packages

A program administrator faced with deleading 5 dwelling units conceivably could let five separate contracts containing specifications for one dwelling unit in each contract or could let one contract with specifications and scopes of work for all five dwelling units. Although contract package size (the number of dwelling units per contract) and the composition of the contract do themselves affect program costs, including them as variables would pose serious computational problems when relying on the hand calculations for estimating abatement costs. (The reader interested in a detailed discussion of this issue is referred to Section 3 of Appendix C.)

For the purpose of the hand calculations, contract packages should be based on administrative convenience, geographic contiguity, and constraints on package size arising from the EHEP cost models. The following guidelines should be kept in mind when grouping dwelling units into contract packages:

- (1) No more than four dwelling units should be placed in any one contract;<sup>1</sup>
- (2) Preference should be given to grouping dwelling units which are locationally near one another;

---

<sup>1</sup> See Section 3 of Appendix D for a discussion of the rationale behind this requirement.

- (3) Contract packages should be grouped so as to disperse evenly the perceived risk of theft or vandalism;
- (4) Contract packages should be organized in such a way that contract monitoring can be effectively carried out.

The first two guidelines above arise from assumptions which were incorporated in the Phase II EHEP cost models. In order to ensure that the Phase II EHEP cost estimation models will be reliable, guidelines (1) and (2) should therefore be followed. Guideline (3) is intended to ensure that the maximum number of contractors will respond to any requests for proposals; while guideline (4) is dependent upon the monitoring resources available to the lead-based paint abatement program.

Task 2: Identifying the Least-Direct-Cost Wall and/or Trim Techniques for Each Dwelling Unit.

Given that the dwelling unit composition of the contract packages has been determined in Task 1, the calculation of the direct costs of the alternative abatement techniques for each dwelling unit can now be undertaken. The data inputs needed to implement these calculations are discussed in Chapter 5 of the companion report Guidelines for Cost Effective Lead Paint Abatement. Worksheet E.1 summarizes the data requirements needed to carry out these calculations. Diagram E.1 traces the flow of steps that ought to be taken once the data has been acquired in order to estimate the direct costs of applying barrier materials.<sup>1</sup>

In Diagram E.1 some of the blocks are labeled with a capital letter. These letters refer the reader to specific work sheets in this appendix which contain the computational routine(s) which is (are) to be carried out at that block. (The worksheets in this appendix can be photocopied to provide the user with an adequate number of worksheets to complete this task.) More than one computational routine may be applicable at any particular step. For example, at block (D) there will be two computational tables describing the steps needed to calculate productivity. One table is needed for cement-coated fiberglass and another for vinyl-coated fabric. An index of the worksheets necessary to do the hand calculations is given in Table E.1. (Table E.1 indexes worksheets related to Diagrams E.1, E.2, and E.3.) As the values of the direct cost for the wall and trim techniques for a particular dwelling unit are computed they should be recorded on a summary sheet. Table E.2 serves as an example of a summary sheet.

The computation procedure for determining the direct costs of trim techniques are outlined by Diagram E.2. Table E.2 also includes space to summarize the costs of the trim techniques.

---

<sup>1</sup> Diagram E.1 should be read carefully before starting the hand calculations.

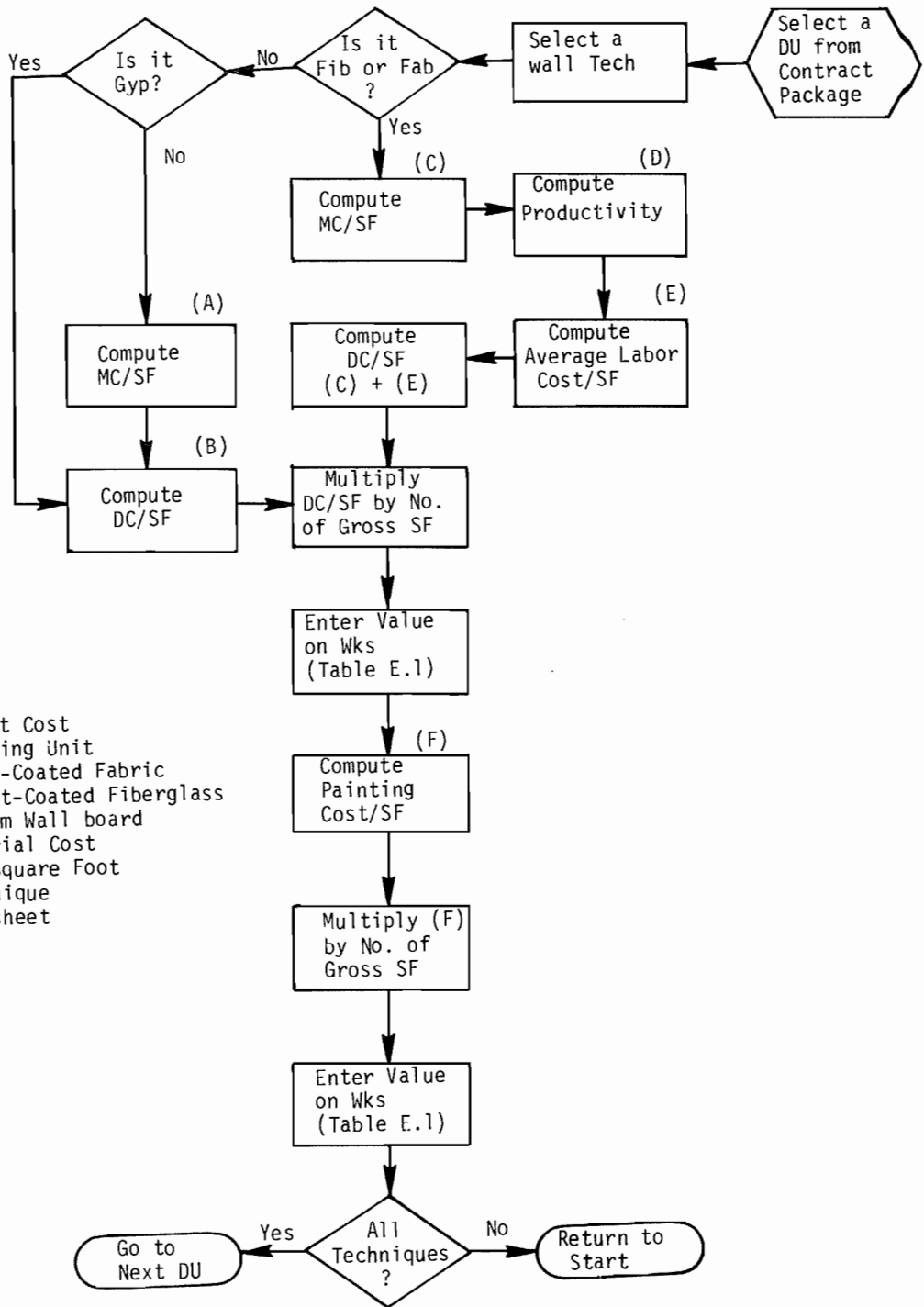

**KEY:**

- DC = Direct Cost
- DU = Dwelling Unit
- Fab= Vinyl-Coated Fabric
- Fib= Cement-Coated Fiberglass
- Gyp= Gypsum Wall board
- MC = Material Cost
- /SF = Per Square Foot
- Tech = Technique
- Wks = Worksheet

DIAGRAM E.1

HOW TO CALCULATE DIRECT COSTS  
FOR WALL TECHNIQUES



TABLE E.1 INDEX OF THE WORKSHEETS NEEDED TO PERFORM HAND CALCULATIONS

| Diagram Reference Number | Block Letter | Worksheet Title and Worksheet Number                            |
|--------------------------|--------------|---|
| n.a.                     | n.a.         | INPUT DATA REQUIREMENTS E.1                                     |
| n.a.                     | n.a.         | CALCULATING AVERAGE WAGE RATES E.2                              |
| E.1                      | B            | DIRECT COST: GYPSUM WALLBOARD E.3                               |
| E.1                      | A            | MATERIAL COST: PLYWOOD PANELING E.4                             |
| E.1                      | B            | DIRECT COST: PLYWOOD PANELING E.5                               |
| E.1                      | A            | MATERIAL COST: CEMENTITIOUS COATING E.6                         |
| E.1                      | B            | DIRECT COST: CEMENTITIOUS COATING E.7                           |
| E.1                      | A            | MATERIAL COST: VENEER PLASTER E.8                               |
| E.1                      | B            | DIRECT COST: VENEER PLASTER E.9                                 |
| E.1                      | C,D,E        | DIRECT COST: CEMENT-COATED FIBERGLASS E.10                      |
| E.1                      | C,D,E        | DIRECT COST: VINYL-COATED FABRIC E.11                           |
| E.1                      | F            | DIRECT COST: WALL PAINTING E.12                                 |
| E.2                      | A,B          | DIRECT COST: INFRA-RED (DOORS OR WINDOWS) E.13                  |
| E.2                      | C            | DIRECT COST: INFRA-RED OR SOLVENT STRIP (BASEBOARDS) E.14       |
| E.2                      | A,B          | DIRECT COST: SOLVENT STRIP (DOORS OR WINDOWS) E.15              |
| E.2                      | A,B          | DIRECT COST: HEAT GUN (DOORS OR WINDOWS) E.16                   |
| E.2                      | A,B,C        | DIRECT COST: HEAT GUN (BASEBOARDS) E.17                         |
| E.2                      | B            | DIRECT COST: HAND SCRAPING (DOORS, WINDOWS, OR BASEBOARDS) E.18 |
| E.2                      | B            | DIRECT COST: COMPONENT REPLACEMENT (DOORS) E.19                 |
| E.2                      | B            | DIRECT COST: COMPONENT REPLACEMENT (DOOR FRAMES) E.20           |
| E.2                      | A            | DIRECT COST: COMPONENT REPLACEMENT (WINDOWS AND FRAMES) E.21    |
| E.2                      | D            | DIRECT COST: PAINTING TRIM (DOORS AND FRAMES) E.22              |
| E.2                      | D            | DIRECT COST: PAINTING TRIM (WINDOWS AND FRAMES) E.23            |
| E.2                      | D            | DIRECT COST: PAINTING TRIM (BASEBOARDS) E.24                    |
| n.a.                     | n.a.         | CONTRACT DATA REQUIREMENTS E.25                                 |
| E.3                      | C            | MARKUP CALCULATION E.26   |
| E.3                      | G            | RECOMPUTING MARKUP E.27   |

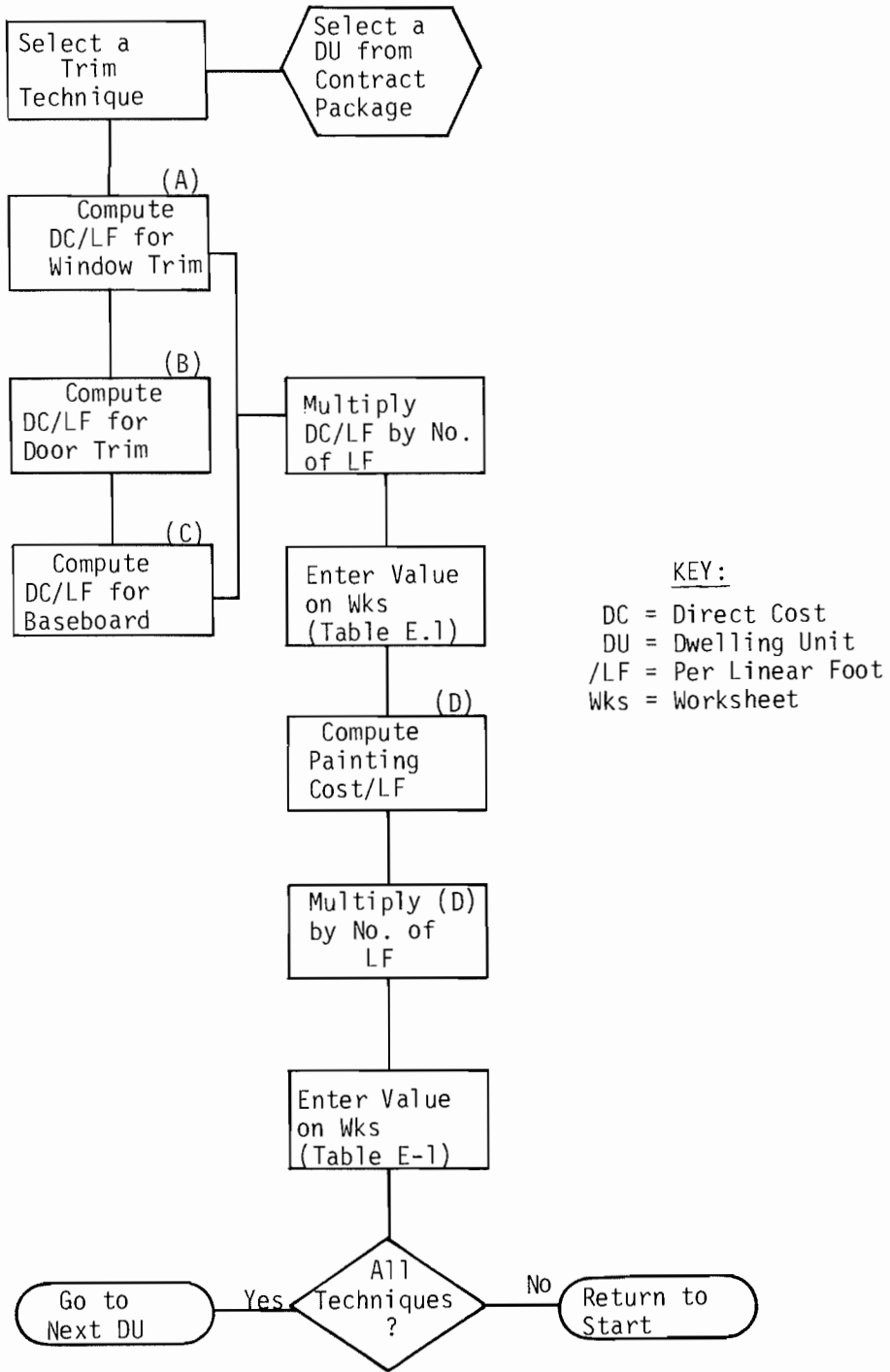

DIAGRAM E.2

HOW TO CALCULATE DIRECT COSTS FOR TRIM TECHNIQUES

TABLE E.2 DWELLING UNIT SUMMARY OF DIRECT COSTS

| Contract ID# _____ Dwelling Unit ID# _____ Room ID# _____ |                             |                   |                     |                                  |
|---|-----------------------------|-------------------|---------------------|----------------------------------|
| Level #   | Technique Name              | Total Direct Cost | Total Painting Cost | Sum of Direct Costs and Painting |
|   | <u>Wall Methods</u>         |                   |                     |                                  |
| 1   | Gypsum Wallboard            |                   |                     |                                  |
| 2   | Plywood Paneling            |                   |                     |                                  |
| 3   | Cementitious Coating        |                   |                     |                                  |
| 4   | Veneer Plaster              |                   |                     |                                  |
| 5   | Cement-Coated Fiberglass    |                   |                     |                                  |
| 6   | Vinyl-Coated Fabric         |                   |                     |                                  |
|   | <u>Doors &amp; Frames</u>   |                   |                     |                                  |
| 7   | Infra-Red                   |                   |                     |                                  |
| 8   | Solvent Strip               |                   |                     |                                  |
| 9   | Hand Scraping               |                   |                     |                                  |
| 10  | Heat Gun                    |                   |                     |                                  |
| 11  | Replacement                 |                   |                     |                                  |
|   | <u>Windows &amp; Frames</u> |                   |                     |                                  |
| 12  | Infra-Red                   |                   |                     |                                  |
| 13  | Solvent Strip               |                   |                     |                                  |
| 14  | Hand Scraping               |                   |                     |                                  |
| 15  | Heat Gun                    |                   |                     |                                  |
| 16  | Replacement                 |                   |                     |                                  |
|   | <u>Baseboards</u>           |                   |                     |                                  |
| 17  | Infra-Red                   |                   |                     |                                  |
| 18  | Solvent Strip               |                   |                     |                                  |
| 19  | Hand Scraping               |                   |                     |                                  |
| 20  | Heat Gun                    |                   |                     |                                  |
| 21  | Replacement                 |                   |                     |                                  |

### Task 3: Computing the Markup Factor for Each Contract.

Direct costs for each technique are determined at the dwelling unit level. The level of markup is determined at the contract level. Furthermore, the contractors' familiarity with the technique affects the level of markup. Specifically, two techniques, gypsum wallboard and plywood paneling (because of their familiarity and thus because of the greater potential competition from other contractors), if listed in the scope of the work of the contract, could cause contractors to lower their bid price. Thus, even though a particular wall technique may be identified as the lowest-direct-cost technique for a particular dwelling unit, it is necessary to determine if substituting gypsum wallboard or plywood paneling (whichever of the two is the lower cost technique in that dwelling unit/room) for the identified least-direct-cost technique, due to its impact on markup, would lead to a lower overall expected bid price for that contract. If the overall expected bid price would fall, then the more expensive technique (in terms of direct cost) should be substituted for the least-direct-cost technique. Thus the purpose of this step is to present an orderly method by which this question can be answered and which, once answered, will lead to the computation of the minimum markup factor for a particular contract.

As was done with Task 2, the solution to this step is outlined in a flow diagram, Diagram E.3. If a computational block is labeled with a capital letter, there will exist a corresponding table in Section E.2 which identifies the required data and computation procedures to be followed at that block. (Table E.1 indexes the required tables.)

### Task 4: Estimating the Minimum Bid-Price for Each Contract.

The final result of Task 3 is the calculation of the predicted level of markup for a given contract. The markup factor computed after going through all the dwelling units at either Block C or Block G in Diagram E.3 will be the markup factor to use for the contract under consideration. Hence, the least-costly (in terms of direct costs) wall and trim techniques have been identified. Gypsum wallboard or plywood paneling have replaced the least-direct-cost techniques in a particular dwelling unit/room observation if it was found that their overall impact on bid price would justify substitution. Thus for each dwelling unit in a contract, wall and trim techniques have been specified, their direct costs estimated, and the overall markup factor has been estimated. The predicted bid price will simply be the product of the contractor's markup factor times the sum of the direct costs for the wall and trim techniques of the dwelling units in the contract package.

The procedure outlined in these four steps provides: (1) a means of determining which abatement techniques should be employed in a particular dwelling unit, (2) a means of estimating direct costs and bid prices, and (3) a method through which a program administrator can evaluate the causes of any divergences between estimated and actual bids.

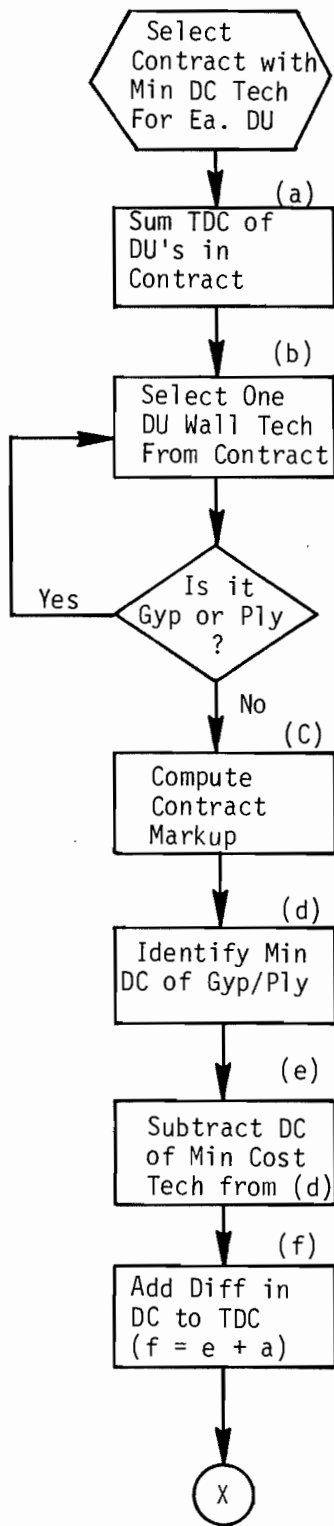

KEY:  
 DC = Direct Cost  
 Diff = Difference  
 DU = Dwelling Unit/Room  
 Gyp = Gypsum Board  
 Min = Minimum  
 Ply = Plywood Panel  
 TDC = Total Direct Cost  
 Tech = Technique

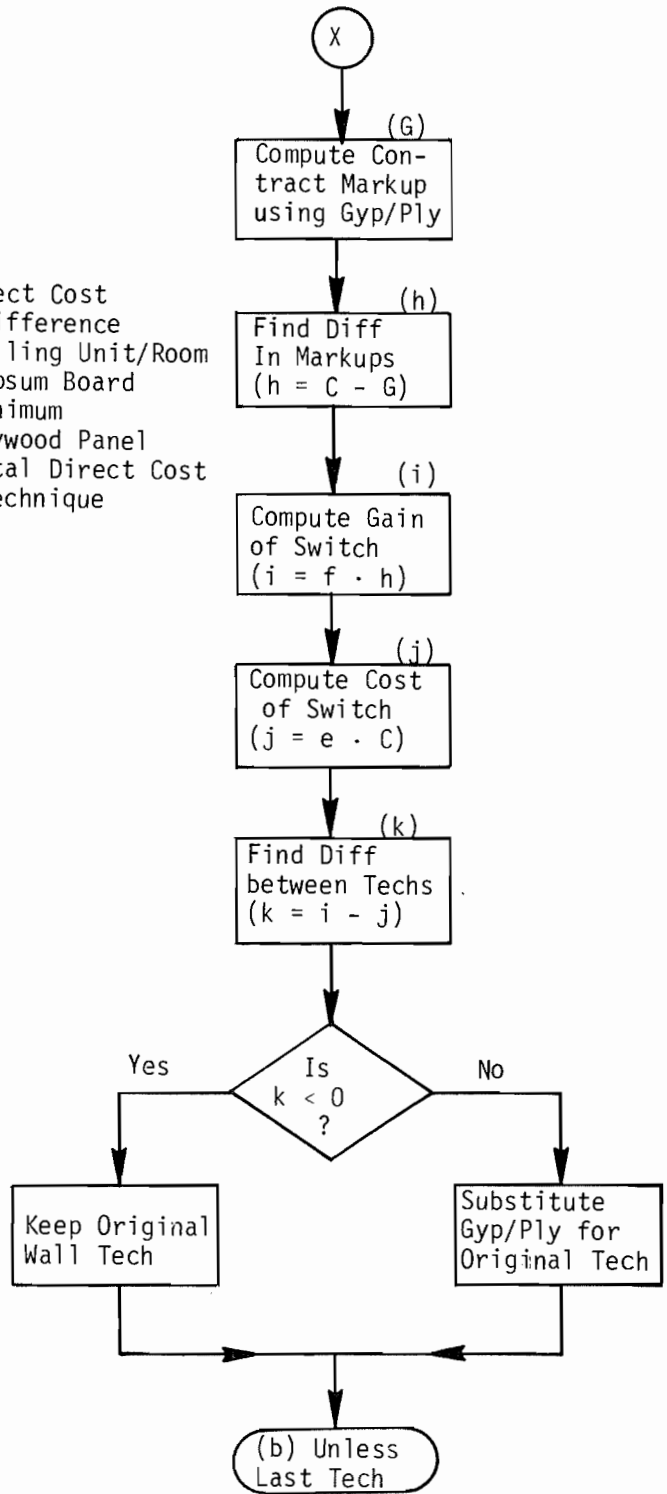

DIAGRAM E.3  
 HOW TO CALCULATE MINIMUM BID PRICE

## E.2 HAND CALCULATION WORKSHEETS

The worksheets that are provided in this section are based on the key factor tables presented in Appendix C.3. In a number of instances a worksheet will differ slightly in form or content from its corresponding key factor table. Such changes have been made in order to simplify the computational procedure and/or the data collection requirements.

Most of the worksheets require that an average wage rate be entered. The appropriate wage rate for a given technique will be found in the calculations relating to average wage rates (see Worksheet E.2). Also note that if a resulting computation of direct cost takes on an implausible value, for example a negative direct cost, Table D.1 should be consulted for guidance. The number of worksheets and the implied time demands of using them may seem excessive but with the use of a hand calculator the calculations will go very quickly. Finally note that the worksheets are indexed in Table E.1 of this appendix.

WORKSHEET E.1  
INPUT DATA REQUIREMENTS

| Data Requirement                        | Nature of Data                                 |
|---|--|
| <hr/>                                   |  |
| Wage                                    | Average Hourly Wage Rate                       |
| Carpenter                               | "  |
| Painter                                 | "  |
| Plasterer                               | "  |
| Paper Hanger                            | "  |
| Apprentice Carpenter                    | "  |
| Laborer                                 | "  |
| Material                                |  |
| Gypsum Wallboard                        | Price per 4' x 8' Sheet                        |
| Plywood Paneling                        | "  |
| Vinyl-Coated Fabric                     | Price per Square Yard                          |
| Flat Latex Wall Paint                   | Price per Gallon                               |
| Semi-Gloss Enamel<br>(Oil Base)         | Price per Gallon                               |
| If Needed:                              |  |
| Unfinished Door                         | Price for One, New                             |
| Unfinished Door Frame                   | "  |
| Unfinished Window and Frame             | Price for Both, New                            |
| Dwelling Unit                           | Observed Value in the Particular Dwelling Unit |
| Gross Sq. Ft. of Wall Area              | Square Feet                                    |
| Linear Ft. of Doors and Frame           | Linear Feet                                    |
| Linear Ft. of Windows and Frames        | "  |
| Linear Ft. of Miscellaneous Trim        | "  |
| Occupancy                               | 1 If Occupied<br>0 If Unoccupied               |
| Wainscotting                            | Percent of Wall Area<br>1 If Poor              |
| Substrate Condition                     | 0 If Satisfactory or Better<br>1 If Needed     |
| Pantry Work                             | 0 If Not<br>1 If 3 or More Layers              |
| Wallpaper on Walls                      | 0 If 2 or Less                                 |
| If Needed:                              |  |
| Number of Doors to Replace              | Number   |
| Number of Door Frames to Replace        | "  |
| Number of Windows and Frames to Replace | "  |
| Address                                 | Address as Specified                           |
| XRF Readings                            | Average or Separate for each Trim Type         |

WORKSHEET E.2

CALCULATING AVERAGE WAGE RATES

| Line | Techniques    | Labor Skill          | Wage Rate <sup>a</sup>                         | x | Weight | = |
|------|---------------|----------------------|--|---|--------|---|
| 1    | Gypsum        | Carpenter            |  | x | 0.6    | = |
| 2    | Wallboard     | Apprentice Carpenter |  | x | 0.4    | = |
| 3    |               |                      | Average Wage<br>(sum of line 1 & line 2)       |   |        | = |
| 4    | Plywood       | Carpenter            |  | x | 0.82   | = |
| 5    | Paneling      | Apprentice Carpenter |  | x | 0.18   | = |
| 6    |               |                      | Average Wage<br>(sum of line 4 & line 5)       |   |        | = |
| 7    | Cementitious  | Carpenter            |  | x | 0.24   | = |
| 8    | Coating       | Apprentice Carpenter |  | x | 0.16   | = |
| 9    |               | Painter              |  | x | 0.60   | = |
| 10   |               |                      | Average Wage<br>(sum of lines 7, 8 & 9)        |   |        | = |
| 11   | Plaster       | Carpenter            |  | x | 0.20   | = |
| 12   | Veneer        | Labor                |  | x | 0.12   | = |
| 13   |               | Painter              |  | x | 0.39   | = |
| 14   |               | Plaster              |  | x | 0.29   | = |
| 15   |               |                      | Average Wage<br>(sum of lines 11, 12, 13 & 14) |   |        | = |
| 16   | Cement-Coated | Carpenter            |  | x | 0.50   | = |
| 17   | Fiberglass    | Painter              |  | x | 0.14   | = |
| 18   |               | Paperhanger          |  | x | 0.36   | = |
| 19   |               |                      | Average Wage<br>(sum of lines 16, 17 & 18)     |   |        | = |
| 20   | Vinyl-        | Painter              |  | x | 0.26   | = |
| 21   | Coated        | Paperhanger          |  | x | 0.48   | = |
| 22   | Fabric        | Carpenter            |  | x | 0.26   | = |
| 23   |               |                      | Average Wage<br>(sum of lines 20, 21 & 22)     |   |        | = |
| 24   | All           | Laborer              |  | x | 0.5    | = |
| 25   | Trim          | Apprentice Carpenter |  | x | 0.5    | = |
| 26   | Techniques    |                      | Average Wage<br>(sum of lines 24 & 25)         |   |        | = |

<sup>a</sup>Enter average hourly wage rate for each skill.



WORKSHEET E.3

DIRECT COST: GYPSUM WALLBOARD

Contract ID# \_\_\_\_\_

Dwelling Unit ID# \_\_\_\_\_

| Step # | Enter Data                                 | Operation   | Weighting Factor | = | Enter Resultant       |
|--------|--|-------------|------------------|---|-----------------------|
| 1.     | _____<br>Gross Square Feet                 | Divide into | 393.06           | = | _____                 |
| 2.     | _____<br>Average Wage Rate                 | Times       | 0.062            | = | _____                 |
| 3.     | _____<br>Price per 4' x 8'<br>Sheet        | Times       | 0.501            | = | _____                 |
| 4.     | _____<br>Pantry Work?<br>Yes = 1<br>No = 0 | Times       | 0.27             | = | _____                 |
| 5.     | _____<br>Sum of Steps 1-4                  | Minus       | 1.770            | = | _____                 |
|        |  |             |                  |   | <u>Direct Cost/SF</u> |

WORKSHEET E.4

MATERIAL COST: PLYWOOD PANELING

Contract ID# \_\_\_\_\_

Dwelling Unit ID# \_\_\_\_\_

| Step # | Enter Data                               | Operation | Weighting Factor | = | Enter Resultant         |
|--------|--|-----------|------------------|---|-------------------------|
| 1.     | <u>Price per 4' x 8' Sheet</u>           | Times     | 0.08             | = | _____                   |
| 2.     | <u>Average Wage Rate</u>                 | Times     | -0.023           | = | _____                   |
| 3.     | <u>Sound Walls?</u><br>Yes = 0<br>No = 1 | Times     | 0.083            | = | _____                   |
| 4.     | <u>Sum of Steps 1-3</u>                  | Times     | 1.0              | = | _____                   |
|        |  |           |                  |   | <u>Material Cost/SF</u> |

WORKSHEET E.5

DIRECT COST: PLYWOOD PANELING

Contract ID# \_\_\_\_\_

Dwelling Unit ID# \_\_\_\_\_

| Step # | Enter Data               | Operation | Weighting Factor | Enter Resultant       |
|--------|--------------------------|-----------|------------------|-----------------------|
| 1.     | <u>Gross Square Feet</u> | Times     | 0.00042          | = _____               |
| 2.     | <u>Average Wage Rate</u> | Times     | 0.0748           | = _____               |
| 3.     | <u>Material Cost/SF*</u> | Times     | 1.2602           | = _____               |
| 4.     | <u>Sum of Steps 1-3</u>  | Minus     | 0.3245           | = _____               |
|        |                          |           |                  | <u>Direct Cost/SF</u> |

\*Enter Resultant from Step 4, Worksheet E.4

WORKSHEET E.6

MATERIAL COST: CEMENTITIOUS COATING

Contract ID# \_\_\_\_\_

Dwelling Unit ID# \_\_\_\_\_

---

| Step # | Enter Data                                 | Operation | Weighting Factor | Enter Resultant           |
|--------|--|-----------|------------------|---------------------------|
| 1.     | _____<br>Sound Walls?<br>Yes = 0<br>No = 1 | Times     | 0.174            | =                         |
| 2.     | _____<br>Result from Step 1                | Plus      | 0.136            | =                         |
|        |  |           |                  | _____<br>Material Cost/SF |

---

WORKSHEET E.7

DIRECT COST: CEMENTITIOUS COATING

Contract ID# \_\_\_\_\_

Dwelling Unit ID# \_\_\_\_\_

| Step # | Enter Data   | Operation | Weighting Factor | = | Enter Resultant       |
|--------|--|-----------|------------------|---|-----------------------|
| 1.     | _____  | Times     | -0.0004          | = | _____                 |
|        | Gross Square Feet  |           |                  |   |                       |
| 2.     | _____  | Times     | 0.11             | = | _____                 |
|        | Average Wage Rate  |           |                  |   |                       |
| 3.     | _____  | Times     | 3.86             | = | _____                 |
|        | Material Cost/SF*  |           |                  |   |                       |
| 4.     | _____  | Times     | 0.14             | = | _____                 |
|        | Wall Paper Stripping?<br>If 3 or More Layers = 1<br>If 2 or Less = 0 |           |                  |   |                       |
| 5.     | _____  | Minus     | 0.80             | = | _____                 |
|        | Sum of Steps 1-4   |           |                  |   |                       |
|        |  |           |                  |   | <u>Direct Cost/SF</u> |

\*Enter Result from Step 2 Worksheet E.6.

WORKSHEET E.8

MATERIAL COST: VENEER PLASTER

Contract ID# \_\_\_\_\_

Dwelling Unit ID# \_\_\_\_\_

| Step # | Enter Data   | Operation | Weighting Factor | Enter Resultant  |
|--------|--|-----------|------------------|--|
| 1.     | <u>  </u><br>Sound Walls?<br>Yes = 0<br>No = 1 | Times     | 0.178 =          | <u>  </u><br><u>  </u> |
| 2.     | <u>  </u><br>Enter Result from<br>Step 1       | Plus      | 0.056 =          | <u>  </u><br><u>  </u> |
|        |  |           |                  | <u>Material Cost/SF</u>  |

WORKSHEET E.9

DIRECT COST: VENEER PLASTER

Contract ID# \_\_\_\_\_

Dwelling Unit ID# \_\_\_\_\_

| Step # | Enter Data  | Operation | Weighting Factor | Enter Resultant         |
|--------|---|-----------|------------------|-------------------------|
| 1.     | _____<br>Gross Square Feet  | Times     | -0.0004 =        | _____                   |
| 2.     | _____<br>Average Wage Rate  | Times     | 0.11 =           | _____                   |
| 3.     | _____<br>Material Cost/SF*  | Times     | 3.86 =           | _____                   |
| 4.     | _____<br>Wallpaper Stripping?<br>If 3 or More Layers = 1<br>If 2 or Less Layers = 0 | Times     | 0.14 =           | _____                   |
| 5.     | _____<br>Sum of Steps 1-4   | Plus      | 1.01 =           | _____<br>Direct Cost/SF |

\*Enter Resultant from Step 2, Worksheet E.8

WORKSHEET E.10

DIRECT COST: CEMENT-COATED FIBERGLASS

Contract ID# \_\_\_\_\_

Dwelling Unit ID# \_\_\_\_\_

| Step # | Enter Data                                 | Operation  | Weighting Factor             | = | Enter Resultant       |
|--------|--|------------|------------------------------|---|-----------------------|
| 1.     | <u>Percent Wall Area Wainscotted</u>       | Times      | -45.5                        | = | _____                 |
| 2.     | <u>Sound Walls?</u><br>Yes = 0<br>No = 1   | Times      | -3.42                        | = | _____                 |
| 3.     | <u>D.U. Occupied?</u><br>Yes = 0<br>No = 1 | Times      | 9.06                         | = | _____                 |
| 4.     | <u>Sum of Lines 1-3</u>                    | Plus       | 17.39                        | = | _____                 |
| 5.     | <u>Average Wage Rate</u>                   | Divided by | <u>Resultant from Line 4</u> | = | _____                 |
| 6.     | <u>Resultant from Line 5</u>               | Times      | 1.05                         | = | _____                 |
| 7.     | <u>Resultant from Line 6</u>               | Plus       | 0.437                        | = | _____                 |
| 8.     | <u>Resultant from Line 7</u>               | Plus       | <u>Resultant From Line 5</u> | = | _____                 |
|        |  |            |                              |   | <u>Direct Cost/SF</u> |



WORKSHEET E.11

DIRECT COST: VINYL-COATED FABRIC

Contract ID# \_\_\_\_\_

Dwelling Unit ID# \_\_\_\_\_

| Step # | Enter Data                           | Operation  | Weighting Factor        | = | Enter Resultant       |
|--------|--------------------------------------|------------|-------------------------|---|-----------------------|
| 1.     | <u>Price per Square Yd.</u>          | Times      | 0.10                    | = | _____                 |
| 2.     | <u>Percent Wall Area Wainscotted</u> | Times      | 0.54                    | = | _____                 |
| 3.     | <u>Percent Wall Area Wainscotted</u> | Times      | -24.8                   | = | _____                 |
| 4.     | <u>Average Hourly Wage</u>           | Times      | 1.29                    | = | _____                 |
| 5.     | <u>Gross Square Feet</u>             | Times      | 0.022                   | = | _____                 |
| 6.     | <u>Sum of Lines 3-5</u>              | Minus      | 8.00                    | = | _____                 |
| 7.     | <u>Average Hourly Wage</u>           | Divided by | <u>Result of Line 6</u> | = | _____                 |
| 8.     | <u>Sum of Lines 1-2</u>              | Plus       | <u>Result of Line 7</u> | = | <u>Direct Cost/SF</u> |

WORKSHEET E.12

DIRECT COST: WALL PAINTING

Contract ID# \_\_\_\_\_

Dwelling Unit ID# \_\_\_\_\_

| Step # | Enter Data  | Operation | Weighting Factor | Enter Resultant           |
|--------|---|-----------|------------------|---------------------------|
| 1.     | _____   | Times     | -0.000296 =      | _____                     |
|        | Gross Square Feet   |           |                  |                           |
| 2.     | _____   | Times     | 0.1736 =         | _____                     |
|        | Ratio of Net-to-Gross SF  |           |                  |                           |
| 3.     | _____   | Times     | 0.0106 =         | _____                     |
|        | Average Wage Rate   |           |                  |                           |
| 4.     | _____   | Times     | 0.0257 =         | _____                     |
|        | Paint Price   |           |                  |                           |
| 5.     | _____   | Times     | -0.000296 =      | _____                     |
|        | Gross SF Ceiling Area   |           |                  |                           |
| 6.     | _____   |           |                  | _____                     |
|        | Sum Steps 1-4, Enter Painting Cost per Square Foot for Techniques Which Need Painting               |           |                  | Painting Cost/SF-Walls    |
| 7.     | _____   |           |                  | _____                     |
|        | Sum Steps 3-5, Enter Painting Cost per Square Foot for Techniques Where Ceilings Are to Be Painted. |           |                  | Painting Cost/SF Ceilings |

WORKSHEET E.13

DIRECT COST: INFRA-RED (DOORS OR WINDOWS)

Contract ID# \_\_\_\_\_

Dwelling Unit ID# \_\_\_\_\_

| Step # | Enter Date                        | Operation  | Weighting Factor         | Enter Resultant |
|--------|-----------------------------------|------------|--------------------------|-----------------|
| 1.     | _____                             | Times      | 0.2903                   | = _____         |
|        | Average Wage Rate                 |            |                          |                 |
| 2.     | _____                             | Times      | -0.0007                  | = _____         |
|        | XRF x Linear Feet                 |            |                          |                 |
| 3.     | _____                             | Divided by | .92 Doors<br>.89 Windows | = _____         |
|        | Sum of Steps 1-2<br>Labor Cost/LF |            |                          |                 |
|        |                                   |            |                          | _____           |
|        |                                   |            |                          | Direct Cost/LF  |

WORKSHEET E.14

DIRECT COST: INFRA-RED OR SOLVENT STRIP (BASEBOARDS)

Contract ID# \_\_\_\_\_

Dwelling Unit ID# \_\_\_\_\_

| Step # | Enter Data                                   | Operation  | Weighting Factor                   | Enter Resultant                  |
|--------|--|------------|------------------------------------|----------------------------------|
| 1.     | <u>Average Wage Rate</u>                     | Times      | 0.1354                             | = _____                          |
| 2.     | <u>Is It Infra-Red?</u><br>Yes = 1<br>No = 0 | Times      | -0.4913                            | = _____                          |
| 3.     | <u>Sum of Steps 1-2</u><br>Labor Cost/LF     | Divided by | .80 Infra-Red<br>.82 Solvent Strip | = _____<br><u>Direct Cost/LF</u> |

WORKSHEET E.15

DIRECT COST: SOLVENT STRIP (DOORS OR WINDOWS)

Contract ID# \_\_\_\_\_

Dwelling Unit ID# \_\_\_\_\_

| Step # | Enter Data               | Operation | Weighting Factor | = | Enter Resultant       |
|--------|--------------------------|-----------|------------------|---|-----------------------|
| 1.     | <u>Average Wage Rate</u> | Times     | 0.5727           | = | _____                 |
| 2.     | <u>XRF x Linear Feet</u> | Times     | -0.0013          | = | _____                 |
| 3.     | <u>Sum of Steps 1-2</u>  | Minus     | 1.3499           | = | <u>Labor Cost/LF</u>  |
| 4.     | <u>Step 3 Result</u>     | Times     | .88              | = | _____                 |
|        |                          |           |                  |   | <u>Direct Cost/LF</u> |

WORKSHEET E.16

DIRECT COST: HEAT GUN (DOORS OR WINDOWS)

Contract ID# \_\_\_\_\_

Dwelling Unit ID# \_\_\_\_\_

| Step # | Enter Data        | Operation | Weighting Factor               | Enter Resultant |
|--------|-------------------|-----------|--------------------------------|-----------------|
| 1.     | _____             | Times     | 0.2775                         | = _____         |
|        | Average Wage Rate |           |                                |                 |
| 2.     | _____             | Times     | -0.00861                       | = _____         |
|        | Linear Feet       |           |                                |                 |
| 3.     | _____             | Plus      | 0.1769 Doors<br>0.4735 Windows | = _____         |
|        | Sum of Steps 1-2  |           |                                | _____           |
|        |                   |           |                                | Direct Cost/LF  |

WORKSHEET E.17

DIRECT COST: HEAT GUN (BASEBOARDS)

Contract ID# \_\_\_\_\_

Dwelling Unit ID# \_\_\_\_\_

| Step # | Enter Data   | Operation | Weighting Factor | = | Enter Resultant   |
|--------|--|-----------|------------------|---|---|
| 1.     | <u>                                </u><br>Average Wage Rate | Times     | 0.1372           | = | <u>                                </u>                   |
| 2.     | <u>                                </u><br>Linear Feet       | Times     | -0.0073          | = | <u>                                </u>                   |
| 3.     | <u>                                </u><br>Sum of Steps 1-2  | Plus      | 0.1406           | = | <u>                                </u>                   |
|        |  |           |                  |   | <u>                                </u><br>Direct Cost/LF |

WORKSHEET E.18

DIRECT COST: HAND SCRAPING (DOORS, WINDOWS, OR BASEBOARDS)

Contract ID# \_\_\_\_\_

Dwelling Unit ID# \_\_\_\_\_

| Step # | Enter Data        | Operation | Weighting Factor | = | Enter Resultant                      |
|--------|-------------------|-----------|------------------|---|--------------------------------------|
| 1.     | _____             | Times     | -0.0213          | = | _____                                |
|        | Linear Feet       |           |                  |   |                                      |
| 2.     | _____             | Times     | 0.3262           | = | _____                                |
|        | Average Wage Rate |           |                  |   |                                      |
| 3.     | _____             | Plus      | 0.9468           | = | _____                                |
|        | Sum of Steps 1-2  |           |                  |   |                                      |
|        |                   |           |                  |   | _____                                |
|        |                   |           |                  |   | Direct Cost/LF<br>(Doors or Windows) |
|        |                   |           |                  |   | (For Baseboard)                      |
| 1.     | _____             | Times     | 0.1146           | = | _____                                |
|        | Average Wage Rate |           |                  |   |                                      |
|        |                   |           |                  |   | _____                                |
|        |                   |           |                  |   | Direct Cost/LF<br>(Baseboards)       |



WORKSHEET E.19

DIRECT COST: COMPONENT REPLACEMENT (DOORS)

Contract ID# \_\_\_\_\_

Dwelling Unit ID# \_\_\_\_\_

| Step # | Enter Data               | Operation | Weighting Factor | Enter Resultant         |
|--------|--------------------------|-----------|------------------|-------------------------|
| 1.     | <u>Average Wage Rate</u> | Times     | -4.5476 =        | _____                   |
| 2.     | <u>Door Price</u>        | Times     | 0.7604 =         | _____                   |
| 3.     | <u>Sum of Steps 1-2</u>  | Plus      | 95.2023 =        | <u>Direct Cost/Unit</u> |

WORKSHEET E.20

DIRECT COST: COMPONENT REPLACEMENT (DOOR FRAMES)

Contract ID# \_\_\_\_\_

Dwelling Unit ID# \_\_\_\_\_

| Step # | Enter Date        | Operation | Weighting Factor | Enter Resultant  |
|--------|-------------------|-----------|------------------|------------------|
| 1.     | _____             | Times     | 5.702 =          | _____            |
|        | Average Wage Rate |           |                  |                  |
| 2.     | _____             | Times     | 1.699 =          | _____            |
|        | Door Frame Price  |           |                  |                  |
| 3.     | _____             |           | =                | _____            |
|        | Sum of Steps 1-2  |           |                  | _____            |
|        |                   |           |                  | Direct Cost/Unit |

WORKSHEET E.21

DIRECT COST: COMPONENT REPLACEMENT (WINDOWS AND FRAMES)

Contract ID# \_\_\_\_\_

Dwelling Unit ID# \_\_\_\_\_

| Step # | Enter Data        | Operation | Weighting Factor | Enter Resultant  |
|--------|-------------------|-----------|------------------|------------------|
| 1.     | _____             | Times     | 6.740            | = _____          |
|        | Average Wage Rate |           |                  |                  |
| 2.     | _____             | Times     | 1.1016           | = _____          |
|        | Purchase Price    |           |                  |                  |
| 3.     | _____             | Plus      | 25.213           | = _____          |
|        | Sum of Steps 1-2  |           |                  |                  |
|        |                   |           |                  | _____            |
|        |                   |           |                  | Direct Cost/Unit |

WORKSHEET E.22

DIRECT COST: PAINTING TRIM (DOORS AND FRAMES)

Contract ID# \_\_\_\_\_

Dwelling Unit ID# \_\_\_\_\_

| Step # | Enter Data                          | Operation | Weighting Factor | Enter Resultant         |
|--------|-------------------------------------|-----------|------------------|-------------------------|
| 1.     | <u>Average Wage Rate of Painter</u> | Times     | 0.7517 =         | _____                   |
| 2.     | <u>Paint Price (Semi-Gloss)</u>     | Times     | 0.9343 =         | _____                   |
| 3.     | <u>Number Doors and Frames</u>      | Times     | -0.8776 =        | _____                   |
| 4.     | <u>Sum of Steps 1-3</u>             |           | =                | _____                   |
|        |                                     |           |                  | <u>Direct Cost/Unit</u> |

WORKSHEET E.23

DIRECT COST: PAINTING TRIM (WINDOWS AND FRAMES)

Contract ID# \_\_\_\_\_

Dwelling Unit ID# \_\_\_\_\_

| Step # | Enter Date                      | Operation | Weighting Factor | Enter Resultant  |
|--------|---------------------------------|-----------|------------------|------------------|
| 1.     | _____                           | Times     | 2.5942 =         | _____            |
|        | Average Wage Rate<br>of Painter |           |                  |                  |
| 2.     | _____                           | Times     | 1.5865 =         | _____            |
|        | Paint Price<br>(Semi-Gloss)     |           |                  |                  |
| 3.     | _____                           | Times     | -3.8199 =        | _____            |
|        | Number Windows<br>and Frames    |           |                  |                  |
| 4.     | _____                           |           | =                | _____            |
|        | Sum of Steps 1-3                |           |                  | _____            |
|        |                                 |           |                  | Direct Cost/Unit |

WORKSHEET E.24

DIRECT COST: PAINTING TRIM (BASEBOARDS)

Contract ID# \_\_\_\_\_

Dwelling Unit ID# \_\_\_\_\_

| Step # | Enter Data                   | Operation | Weighting Factor | Enter Resultant |
|--------|------------------------------|-----------|------------------|-----------------|
| 1.     | Average Wage Rate of Painter | Times     | 0.0388           | Direct Cost/LF  |

## WORKSHEET E.25

## CONTRACT DATA REQUIREMENTS

---

| Line | Item                               | Entry |
|------|------------------------------------|-------|
| 1.   | Number of DUS/rooms in Contract    |       |
| 2.   | Total Net Square Feet of Wall Area |       |
| 3.   | Total Linear Feet of Trim          |       |
| 4.   | Net SF of (Tech)/DU ID#'s          |       |
|      | a) Gypsum Wallboard                |       |
|      | b) Plywood Paneling                |       |
|      | c) Cementitious Coating            |       |
|      | d) Veneer Plaster                  |       |
|      | e) Cement-Coated Fiberglass        |       |
|      | f) Vinyl-Coated Fabric             |       |
| 5.   | Sum of 4(a) plus 4(b)              |       |
| 6.   | Final value of Markup Factor       |       |

---

WORKSHEET E.26

MARKUP CALCULATION

Contract ID# \_\_\_\_\_

Dwelling Unit ID# \_\_\_\_\_

| Step # | Enter Data                     | Operation | Weighting Factor | Enter Resultant      |
|--------|--------------------------------|-----------|------------------|----------------------|
| 1.     | <u>100's of NSF</u>            | Times     | -0.01 =          | _____                |
| 2.     | <u>100's of LF</u>             | Times     | 0.05 =           | _____                |
| 3.     | <u>Fraction Gyp or Plywood</u> | Times     | -0.2144 =        | _____                |
| 4.     | <u>Sum of Steps 1-3</u>        | Plus      | 1.2972 =         | _____                |
|        |                                |           |                  | <u>Markup Factor</u> |



WORKSHEET E.27  
RECOMPUTING MARKUP

Contract ID# \_\_\_\_\_

Dwelling Unit ID# \_\_\_\_\_

| Step # | Enter Data                               | Operation  | Weighting Factor                            | Enter Resultant                |
|--------|--|------------|---|--------------------------------|
| 1.     | <u>NSF of Wall Area<br/>This DU/Room</u> | Divided by | <u>Net SF Wall<br/>Area in<br/>Contract</u> | = _____                        |
| 2.     | <u>Enter Result of<br/>Step 2</u>        | Times      | 0.214                                       | = _____                        |
| 3.     | <u>Initial Markup<br/>Factor</u>         | Minus      | <u>Result of<br/>Step 2</u>                 | = <u>New Markup<br/>Factor</u> |

APPENDIX F

LISTING OF COMPUTER PROGRAM

00001REMP20CHAIN RUNNH:J0003\*\*\*

00010REMS141. DESCRIPTION

00012REMS01

00014REMS62 J0003 WILL ANALYZE THE COSTS OF THE ALTERNATIVE METHODS FOR

00016REMS01

00018REMS62 ELIMINATING THE LEAD PAINT HAZARD FROM A DWELLING UNIT. THE

00020REMS01

00022REMS60 PROGRAM PERMITS THE USER TO INPUT SPECIFIC INFORMATION ON

00024REMS01

00026REMS62 ANTICIPATED CONTRACT PACKAGES OF DWELLING UNITS. THE LEAST-

00028REMS01

00030REMS61 COST COMBINATION OF ABATEMENT TECHNIQUES FOR EACH DWELLING

00032REMS01

00034REMS63 UNIT IS IDENTIFIED. DWELLING UNITS ARE GROUPED TOGETHER INTO

00036REMS01

00038REMS63 CONTRACT PACKAGES SO THAT THE SUM OF THE EXPECTED BID PRICES

00040REMS01

00042REMS60 IS MINIMIZED. THE EXPECTED BID PRICE FOR EACH CONTRACT IS

00044REMS01

00046REMS60 GIVEN. EXPECTED CONTRACT COSTS FOR EACH DWELLING UNIT ARE

00048REMS01

00050REMS14 ALSO GIVEN.

00052REMS01

00054REMS142. LIMITATIONS

00056REMS01

00058REMS62 J0003 WILL HANDLE ANTICIPATED CONTRACT PACKAGES OF UP TO 10

00060REMS01

00062REMS60 DWELLING UNITS. DATA FOR EACH DWELLING UNIT IS ENTERED IN

00064REMS01

00066REMS37 RESPONSE TO INQUIRIES AT RUN TIME.

00068REMS01

00070REMS073. DATA

00072REMS01

00074REMS58 TWO TYPES OF DATA ARE INPUT, CONTRACT SPECIFIC DATA AND

00076REMS01

00078REMS63 DWELLING UNIT SPECIFIC DATA. INPUT DATA FOR EACH ANTICIPATED

00080REMS01

00082REMS38 CONTRACT CONSISTS OF THE FOLLOWING:

00084REMS01

00086REMS27 A. CONTRACT SPECIFIC DATA

00088REMS01

00090REMS09 WAGE

00092REMS54

AVERAGE HOURLY

00094REMS51 CARPENTER

WAGE RATE

00096REMS01

00098REMS48 PAINTER

"

|             |                                  |   |
|-------------|----------------------------------|---|
| ØØ1ØØREMSØ1 |                                  |   |
| ØØ1Ø2REMS48 | PLASTERER                        | "   |
| ØØ1Ø4REMSØ1 |                                  |   |
| ØØ1Ø6REMS48 | PAPER HANGER                     | "   |
| ØØ1Ø8REMSØ1 |                                  |   |
| ØØ11ØREMS48 | APPRENTICE CARPENTER             | "   |
| ØØ112REMSØ1 |                                  |   |
| ØØ114REMS48 | LABORER                          | "   |
| ØØ116REMSØ1 |                                  |   |
| ØØ118REMS13 | MATERIAL                         |   |
| ØØ12ØREMSØ1 |                                  |   |
| ØØ122REMS63 | GYPSUM WALLBOARD                 | PRICE PER 4' x 8' SHEET                                 |
| ØØ124REMSØ1 |                                  |   |
| ØØ126REMS54 | PLYWOOD PANELING                 | "   |
| ØØ128REMSØ1 |                                  |   |
| ØØ13ØREMS61 | VINYL-COATED FABRIC              | PRICE PER SQUARE YARD                                   |
| ØØ132REMSØ1 |                                  |   |
| ØØ134REMS56 | LATEX FLAT WALL PAINT            | PRICE PER GALLON  |
| ØØ136REMSØ1 |                                  |   |
| ØØ138REMS48 | SEMI-GLOSS ENAMEL                | "   |
| ØØ14ØREMS18 | (OIL BASE)                       |   |
| ØØ142REMSØ1 |                                  |   |
| ØØ144REMS15 | IF NEEDED:                       |   |
| ØØ146REMSØ1 |                                  |   |
| ØØ148REMS58 | UNFINISHED DOOR                  | PRICE FOR ONE, NEW                                      |
| ØØ15ØREMSØ1 |                                  |   |
| ØØ152REMS51 | UNFINISHED DOOR FRAME            | "   |
| ØØ154REMSØ1 |                                  |   |
| ØØ156REMS59 | UNFINISHED WINDOW AND FRAME      | PRICE FOR BOTH, NEW                                     |
| ØØ158REMSØ1 |                                  |   |
| ØØ16ØREMS23 | B. DWELLING UNIT DATA            |   |
| ØØ162REMSØ1 |                                  |   |
| ØØ164REMS51 | GROSS SQ. FT. OF WALL AREA       | SQUARE FEET   |
| ØØ166REMSØ1 |                                  |   |
| ØØ168REMS51 | LINEAR FT. OF DOORS AND FRAMES   | LINEAR FEET   |
| ØØ17ØREMSØ1 |                                  |   |
| ØØ172REMS46 | LINEAR FT. OF WINDOWS & FRAMES   | "   |
| ØØ174REMSØ1 |                                  |   |
| ØØ176REMS46 | LINEAR FT. OF MISCELLANEOUS TRIM | "   |
| ØØ178REMSØ1 |                                  |   |
| ØØ18ØREMS61 | OCCUPANCY                        | PERCENT OCCUPIED OR 1 IF OCCUPIED<br>Ø IF UNOCCUPIED    |
| ØØ182REMS63 |                                  |   |
| ØØ184REMS48 | WAINSCOTING                      | PERCENT OF WALL AREA                                    |
| ØØ186REMSØ1 |                                  |   |
| ØØ188REMS43 | SUBSTRATE CONDITION              | PERCENT UNSOUND OR 1 IF POOR<br>Ø IF NOT                |
| ØØ19ØREMSØ1 |                                  |   |
| ØØ192REMS61 | PANTRY WORK                      | PERCENT NEEDING IT OR 1 IF NEEDED<br>Ø IF NOT           |
| ØØ194REMS58 |                                  |   |
| ØØ196REMS63 | WALLPAPER ON WALLS               | PERCENT HAVING >2 LAYERS, 1 IF 3 OR<br>MORE LAYERS Ø IF |
| ØØ198REMS6Ø |                                  |   |
| ØØ2ØØREMS48 | IF NEEDED:                       | NONE  |

00202REMS01  
00204REMS36 NUMBER OF DOORS TO BE REPLACED  
00206REMS01  
00208REMS38 NUMBER OF DOOR FRAMES TO REPLACE  
00210REMS01  
00212REMS34 NUMBER OF WINDOWS AND FRAMES  
00214REMS17 TO REPLACE  
00216REMS01  
00218REMS60 ADDRESS DU/AGE CATEGORY ADDRESS AS SPECIFIED  
00220REMS01  
00222REMS42 XRF READINGS AVERAGE OR SEPARATE OR  
00224REMS38 FOR EACH TRIM TYPE  
10000 FILES WAGE;MATL;AWR  
10005 DIM D(10,10),F(10,10),L(10,10),P(10,10)  
10010 DIM W(10,10),Y(10,10),Z(5,10),X(45,3)  
10015 DIM Z\$(10),P\$(10),Y\$(10),Q\$(10)  
10020 REM READ NAMES OF WALL TECHNIQUES INTO VARIABLES  
10025 READ A\$,B\$,C\$,D\$,E\$,F\$  
10030 DATA GYPSUM WALLBOARD,PLYWOOD PANELING,CEMENTITIOUS COATING  
10035 DATA VENEER PLASTER ,VINYL-COATED FABRIC,CEMENT-COATED FIBERGLASS  
10040 REM READ NAMES OF TRIM TECHNIQUES INTO VARIABLES  
10045 READ G\$,H\$,I\$,J\$  
10050 DATA INFRA-RED DEVICE,SOLVENT STRIP ,ELECTRIC HEAT GUN  
10055 DATA HAND SCRAPING ,  
10060 MAT READ F(7,6)  
10065 DATA 0.6,0,0,0,0.4,0,0.82,0,0,0.18,0,0.24,0.6,0,0.16,0  
10070 DATA 0.20,0.39,0.29,0,0,0.12,0.26,0.26,0,0.48,0,0  
10075 DATA 0.50,0.14,0,0.36,0,0,0,0,0,0.5,0.5  
10080 READ K\$,L\$  
10085 DATA NONE ,COMPONENT REPLACEMENT ONLY  
10090 REM WAGE RATES STORED AS W(I,1) FOR MATRIX MULTIPLICATION  
10095 PRINT "WAGE RATE INFORMATION"  
10100 PRINT  
10105 MAT W=ZER(6,1)  
10110 PRINT "INPUT WAGE RATE PER HOUR FOR CARPENTER"  
10115 INPUT W(1,1)  
10120 PRINT "INPUT WAGE RATE PER HOUR FOR PAINTER"  
10125 INPUT W(2,1)  
10130 PRINT "INPUT WAGE RATE PER HOUR FOR PLASTERER"  
10135 INPUT W(3,1)  
10140 PRINT "INPUT WAGE RATE PER HOUR FOR PAPERHANGER"  
10145 INPUT W(4,1)  
10150 PRINT "INPUT WAGE RATE PER HOUR FOR APPRENTICE CARPENTER"  
10155 INPUT W(5,1)  
10160 PRINT "INPUT WAGE RATE PER HOUR FOR LABORER"  
10165 INPUT W(6,1)  
10170 MAT L=ZER(7,1)  
10175 MAT L=F\*W  
10180 SCRATCH #1  
10185 SCRATCH #3  
10190 MAT WRITE #1,W

```

10195 MAT WRITE #3,L
10200 REM MATERIAL PRICES STORED AS M(I)
10205 PRINT
10210 PRINT
10215 PRINT "MATERIAL PRICE INFORMATION"
10220 PRINT
10225 SCRATCH #2
10230 PRINT "INPUT PRICE OF 4 FT BY 8 FT SHEET OF GYPSUM WALLBOARD"
10235 INPUT M(1)
10240 PRINT "INPUT PRICE OF 4 FT BY 8 FT SHEET OF PLYWOOD PANELING"
10245 INPUT M(2)
10250 PRINT "INPUT PRICE PER SQUARE YARD OF VINYL-COATED FABRIC"
10255 INPUT M(3)
10260 PRINT "INPUT PRICE PER GALLON OF LATEX FLAT WALL PAINT"
10265 INPUT M(4)
10270 PRINT "INPUT PRICE PER GALLON OF SEMI-GLOSS ENAMEL (OIL BASE)"
10275 INPUT M(5)
10280 FOR L=1 TO 5
10285 WRITE #2,M(L)
10290 NEXT L
10295 PRINT "TYPE 1 IF THERE ARE ANY DOORS, DOOR FRAMES OR WINDOWS"
10300 PRINT "AND FRAMES THAT NEED TO BE REPLACED, 0 IF NOT"
10305 INPUT Q
10310 IF Q=0 THEN 10345
10315 PRINT "INPUT PRICE OF NEW, UNFINISHED DOOR"
10320 INPUT M(6)
10325 PRINT "INPUT PRICE OF NEW, UNFINISHED DOOR FRAME"
10330 INPUT M(7)
10335 PRINT "INPUT PRICE OF NEW, UNFINISHED WINDOW AND FRAME"
10340 INPUT M(8)
10345 PRINT
10350 REM COMPUTE AVERAGE WAGE RATES FOR EACH WALL TECHNIQUE AND FOR TRIM
10355 PRINT "IF PROGRAM COST ESTIMATES ARE DESIRED, TYPE 1, IF"
10360 PRINT "CONTRACT COST ESTIMATES ARE DESIRED, TYPE 0"
10365 INPUT P
10370 IF P=1 THEN 10395
10375 PRINT "INPUT NUMBER OF DWELLING UNITS TO BE DONE (MUST BE <= 10)"
10380 INPUT N
10385 LET N9=N
10390 GO TO 10400
10395 LET N=1
10400 PRINT
10405 PRINT "STOP FOR A MINUTE AND CHECK THE DATA YOU HAVE JUST INPUT"
10410 PRINT "IF ANY ERROR WAS MADE IN ENTERING IT, YOU MAY TYPE 1"
10415 PRINT "TO REPEAT INPUT STATEMENTS; IF NOT, TYPE 0 TO CONTINUE"
10420 INPUT Z
10425 IF Z<>1 THEN 10435
10430 IF Z=1 THEN 10295
10435 IF Z=1 THEN 10095
10440 REM N2 IS NUMBER OF CONTRACTS, N3 IS NUMBER OF PAIRS
10445 IF INT(N/2)=N/2 THEN 10465

```

```

10450 LET N2=(N+1)/2
10455 LET N3=N2-1
10460 GO TO 10475
10465 LET N2=N/2
10470 LET N3=N2
10475 MAT F=ZER(N,10)
10480 REM INPUT DU INFORMATION THAT MUST BE STORED FOR COMPUTING
10485 REM MARKUP AND BID PRICE
10490 FOR J=1 TO N
10495 IF P=0 THEN 10510
10500 PRINT "                DWELLING UNIT INFORMATION"
10505 GO TO 10525
10510 PRINT
10515 PRINT
10520 PRINT "                DWELLING UNIT NUMBER"J
10525 PRINT
10530 PRINT "TYPE IN AN IDENTIFYING ADDRESS OR DU TYPE FOR THIS DWELLING UNIT"
10535 INPUT Q$(J)
10540 IF P=0 THEN 10560
10545 PRINT "FOR POLICY ESTIMATES INPUT AVERAGES FOR SQUARE FEET, LINEAR FEET,"
10550 PRINT "XRF, ETC.; AND PERCENTAGE OF SAMPLE NEEDED FOR THOSE VARIABLES"
10555 PRINT "REQUIRING A 1 OR 0"
10560 PRINT "INPUT GROSS SQUARE FEET OF WALL AREA"
10565 INPUT D(1,J)
10570 REM D(2,J) IS NET SQUARE FEET OF WALL AREA
10575 IF D(1,J)<400 THEN 10590
10580 LET D(2,J)=77+0.64*D(1,J)
10585 GO TO 10595
10590 LET D(2,J)=0.83*D(1,J)
10595 PRINT "INPUT LINEAR FEET OF DOORS PLUS LINEAR FEET OF DOOR"
10600 PRINT "FRAMES REQUIRING PAINT REMOVAL"
10605 INPUT D(3,J)
10610 REM D8 IS NUMBER OF DOORS AND FRAMES TO BE DELEADED
10615 LET D8=D(3,J)/8
10620 PRINT "INPUT LINEAR FEET OF WINDOWS PLUS LINEAR FEET OF"
10625 PRINT "WINDOW FRAMES REQUIRING PAINT REMOVAL"
10630 INPUT D(4,J)
10635 REM D7 IS NUMBER OF WINDOWS AND FRAMES TO BE DELEADED
10640 LET D7=D(4,J)/7
10645 PRINT "INPUT LINEAR FEET OF MISCELLANEOUS TRIM REQUIRING"
10650 PRINT "PAINT REMOVAL"
10655 INPUT D(5,J)
10660 LET D(7,J)=D(3,J)+D(4,J)+D(5,J)
10665 PRINT "TYPE 1 IF UNIT IS OCCUPIED, 0 IF NOT"
10670 INPUT D(6,J)
10675 REM INPUT OTHER DU RELATED DATA NECESSARY FOR CALCULATIONS
10680 IF D(1,J)=0 THEN 10735
10685 PRINT "INPUT PERCENT OF WALL AREA THAT IS WAINSCOATED"
10690 PRINT "(TYPE AS A DECIMAL, E.G., 0.25 FOR 25 PERCENT)"
10695 INPUT E(3)
10700 PRINT "TYPE 1 IF SUBSTRATE CONDITION IS POOR, 0 IF NOT"

```

```

10705 INPUT E(4)
10710 PRINT "TYPE 1 IF PANTRY WORK IS NECESSARY, 0 IF NOT"
10715 INPUT E(5)
10720 PRINT "TYPE 1 IF 3 OR MORE LAYERS OF WALLPAPER ARE ON WALLS,"
10725 PRINT "0 IF NOT"
10730 INPUT E(6)
10735 IF Q=0 THEN 10770
10740 PRINT "INPUT NUMBER OF DOORS TO BE REPLACED"
10745 INPUT E(7)
10750 PRINT "INPUT NUMBER OF DOOR FRAMES TO BE REPLACED"
10755 INPUT E(8)
10760 PRINT "INPUT NUMBER OF WINDOWS & FRAMES TO BE REPLACED"
10765 INPUT E(9)
10770 IF D(1,J)<>0 THEN 10810
10775 LET Z1=0
10780 LET C8=0
10785 LET C9=0
10790 LET B8=0
10795 LET B9=0
10800 LET B(1)=0
10805 GO TO 10815
10810 LET Z1=9
10815 IF D(7,J)=0 THEN 10905
10820 PRINT "TYPE 1 IF SEPARATE XRF READINGS ARE AVAILABLE FOR DOORS,"
10825 PRINT "WINDOWS AND MISCELLANEOUS TRIM, 0 IF ONLY AN AVERAGE"
10830 PRINT "IS AVAILABLE"
10835 INPUT Y
10840 IF Y=1 THEN 10875
10845 PRINT "INPUT AVERAGE XRF READING"
10850 INPUT X
10855 LET X1=X
10860 LET X2=X
10865 LET X3=X
10870 GO TO 10905
10875 PRINT "INPUT XRF READING FOR DOORS AND DOOR FRAMES"
10880 INPUT X1
10885 PRINT "INPUT XRF READING FOR WINDOWS AND FRAMES"
10890 INPUT X2
10895 PRINT "INPUT XRF READING FOR MISCELLANEOUS TRIM"
10900 INPUT X3
10905 PRINT "STOP AND CHECK THE DATA FOR THIS DWELLING UNIT"
10910 PRINT "IF THERE IS AN ERROR, TYPE 1 TO REPEAT INPUT STATEMENTS"
10915 PRINT "IF NOT, TYPE 0"
10920 INPUT Z
10925 IF Z=1 THEN 10520
10930 REM COMPUTE PAINTING COST FOR WALLS AND CEILINGS
10935 IF Z1=0 THEN 11025
10940 LET C8=1.35*(D(1,J)/39.95)+2
10945 LET C9=D(1,J)+C8
10950 REM B8 IS PAINTING COST FOR ALL TECHNIQUES BUT GYP AND VENEER PLASTER
10955 LET B8=-0.000296*C8+0.0106*W(2,1)+0.0257*M(4)+0.1736*D(2,J)/D(1,J)

```

```

10960 IF B8 >= 0.08 THEN 10970
10965 LET B8 = 0.08
10970 REM B9 IS PAINTING COST FOR GYP AND VENEER PLASTER
10975 LET B9 = -0.000296*C9 + 0.0106*W(2,1) + 0.0257*M(4) + 0.1736*D(2,J)/D(1,J)
10980 IF B9 >= 0.08 THEN 10990
10985 LET B9 = 0.08
10990 LET B(1) = -1.7700 + 306.5874/D(2,J) + 0.0620*L(1,1)
10995 LET B = 0.5009*M(1) + 0.2740*E(5)
11000 REM GYPSUM WALLBOARD
11005 LET B(1) = B(1) + B
11010 IF B(1) >= 0.25 THEN 11020
11015 LET B(1) = 0.25
11020 LET B(1) = B(1)*D(1,J) + B9*C9
11025 LET C(J) = B(1)
11030 LET G(J) = B(1)
11035 LET Z$(J) = A$
11040 LET P$(J) = A$
11045 IF Z1 <> 0 THEN 11080
11050 LET Z$(J) = K$
11055 FOR K = 2 TO 6
11060 LET B(K) = 0
11065 NEXT K
11070 GO TO 11340
11075 REM PLYWOOD PANELING
11080 LET A(2) = 0.07995*M(2) - 0.0231*L(2,1) + 0.0829*E(4)
11085 LET B(2) = -0.3245 + 0.00054*D(2,J) + 0.0748*L(2,1) + 1.2602*A(2)
11090 IF B(2) >= 0.77 THEN 11100
11095 LET B(2) = 0.77
11100 LET B(2) = B(2)*D(1,J) + B8*C8
11105 IF C(J) <= B(2) THEN 11130
11110 LET C(J) = B(2)
11115 LET G(J) = B(2)
11120 LET Z$(J) = B$
11125 LET P$(J) = B$
11130 REM CEMENTITIOUS COATING
11135 LET A(3) = -0.5002 + 0.6872*D(2,J)/D(1,J) + 0.1037 + 0.1741*E(4)
11140 LET B(3) = -0.8817 - 0.0004*D(1,J) + 0.1154*L(3,1) + 3.8636*A(3) + 0.1416*E(6)
11145 IF B(3) >= 0.22 THEN 11155
11150 LET B(3) = 0.22
11155 LET B(3) = B(3)*D(1,J) + B8*C8
11160 IF C(J) <= B(3) THEN 11175
11165 LET C(J) = B(3)
11170 LET Z$(J) = C$
11175 REM VENEER PLASTER
11180 LET A(4) = A(3) - 0.0847
11185 LET B(4) = 0.8817 - 0.0004*D(1,J) + 0.1154*L(4,1) + 3.8636*A(4) + 0.1416*E(6) + 0.206
11190 IF B(4) >= 0.35 THEN 11200
11195 LET B(4) = 0.35
11200 LET B(4) = B(4)*D(1,J) + B9*C9
11205 IF C(J) <= B(4) THEN 11220
11210 LET C(J) = B(4)

```



```

11215 LET Z$(J)=D$
11220 REM VINYL-COATED FABRIC
11225 LET R(5)=-25.2456+0.0276*D(2,J)+22.0745*D(2,J)/D(1,J)
11230 LET R=1.2933*L(5,1)-24.8364*E(3)
11235 LET R(5)=R(5)+R
11240 LET A(5)=0.0958*M(2)+0.5447*E(3)
11245 LET B(5)=L(5,1)/R(5)+A(5)
11250 IF B(5)>=0.84 THEN 11260
11255 LET B(5)=0.84
11260 LET B(5)=B(5)*D(1,J)+B8*C8
11265 IF C(J)<=B(5) THEN 11280
11270 LET C(J)=B(5)
11275 LET Z$(J)=E$
11280 REM CEMENT-COATED FIBERGLASS
11285 LET R(6)=43.5809-33.6107*D(2,J)/D(1,J)-45.5105*E(3)
11290 LET R=-3.4202*E(4)+8.1578
11295 LET R(6)=R(6)+R
11300 LET A(6)=0.5600*D(2,J)/D(1,J)+1.0900*L(6,1)/R(6)
11305 LET B(6)=L(6,1)/R(6)+A(6)
11310 IF B(6)>=0.66 THEN 11320
11315 LET B(6)=0.66
11320 LET B(6)=B(6)*D(1,J)+B8*C8
11325 IF C(J)<=B(6) THEN 11340
11330 LET C(J)=B(6)
11335 LET Z$(J)=F$
11340 REM FIND XRF TIMES LINEAR FEET FOR TRIM
11345 LET Y1=X1*D(3,J)
11350 LET Y2=X2*D(4,J)
11355 LET Y3=X3*D(5,J)
11360 REM FIND MINIMUM DIRECT COST TECHNIQUE FOR TRIM
11365 REM S(I)=DOORS T(I)=WINDOWS U(I)=TRIM V(I)=TOTAL
11370 REM INFRA-RED HEATING DEVICE
11375 IF D(6,J)=1 THEN 11445
11380 LET S(1)=(0.2903*L(7,1)-0.0007*Y1)/0.92
11385 IF S(1)>=1.05 THEN 11395
11390 LET S(1)=1.05
11395 LET T(1)=(0.2903*L(7,1)-0.0007*Y2)/0.89
11400 IF T(1)>=1.05 THEN 11410
11405 LET T(1)=1.05
11410 LET U(1)=(0.1354*L(7,1)-0.4913)/0.80
11415 IF U(1)>=0.29 THEN 11425
11420 LET U(1)=0.29
11425 LET V(1)=S(1)*D(3,J)+T(1)*D(4,J)+U(1)*D(5,J)
11430 LET H(J)=V(1)
11435 LET Y$(J)=G$
11440 GO TO 11455
11445 LET H(J)=1000000
11450 LET V(1)=0
11455 REM SOLVENT-BASED PAINT REMOVER
11460 LET S(2)=(-1.3499+0.5727*L(7,1)-0.0013*Y1)/0.88
11465 IF S(2)>=1.25 THEN 11475

```

```

11470 LET S(2)=1.25
11475 LET T(2)=(-1.3499+0.5727*L(7,1)-0.0013*Y2)/0.88
11480 IF T(2)>=1.25 THEN 11490
11485 LET T(2)=1.25
11490 LET U(2)=0.1354*L(7,1)/0.82
11495 IF U(2)>=0.51 THEN 11505
11500 LET U(2)=0.51
11505 LET V(2)=S(2)*D(3,J)+T(2)*D(4,J)+U(2)*D(5,J)
11510 IF H(J)<=V(2) THEN 11525
11515 LET H(J)=V(2)
11520 LET Y$(J)=H$
11525 REM ELECTRIC HEAT GUN
11530 LET S(3)=0.2775*L(7,1)-0.00861*D(3,J)+0.1769
11535 IF S(3)>=0.58 THEN 11545
11540 LET S(3)=0.58
11545 LET T(3)=0.2775*L(7,1)-0.00861*D(4,J)+0.4735
11550 IF T(3)>=0.58 THEN 11560
11555 LET T(3)=0.58
11560 LET U(3)=0.1372*L(7,1)-0.0073*D(5,J)+0.1406
11565 IF U(3)>=0.17 THEN 11575
11570 LET U(3)=0.17
11575 LET V(3)=S(3)*D(3,J)+T(3)*D(4,J)+U(3)*D(5,J)
11580 IF H(J)<=V(3) THEN 11595
11585 LET H(J)=V(3)
11590 LET Y$(J)=I$
11595 REM HAND SCRAPING
11600 LET S(4)=0.9468-0.0213*D(3,J)+0.3262*L(7,1)
11605 IF S(4)>=1.16 THEN 11615
11610 LET S(4)=1.16
11615 LET T(4)=0.9468-0.0213*D(4,J)+0.3262*L(7,1)
11620 IF T(4)>=1.16 THEN 11630
11625 LET T(4)=1.16
11630 LET U(4)=0.1146*L(7,1)
11635 IF U(4)>=0.45 THEN 11645
11640 LET U(4)=0.45
11645 LET V(4)=S(4)*D(3,J)+T(4)*D(4,J)+U(4)*D(5,J)
11650 IF H(J)<=V(4) THEN 11665
11655 LET H(J)=V(4)
11660 LET Y$(J)=V$
11665 REM PAINTING COSTS FOR TRIM
11670 LET S(9)=(0.7517*W(2,1)+0.9343*M(5)-0.8776*D8)*D8
11675 LET T(9)=(2.5942*W(2,1)+1.5865*M(5)-3.8199*D7)*D7
11680 LET U(9)=(0.0388*W(2,1)*D(5,J)
11685 LET V(9)=S(9)+T(9)+U(9)
11690 REM V(9) IS TOTAL COST FOR PAINTING TRIM-ALL TECHNIQUES
11695 IF V(9)>=0.09*D(7,J) THEN 11705
11700 LET V(9)=0.09*D(7,J)
11705 REM COMPONENT REPLACEMENT COST
11710 LET S(8)=(0.7517*W(2,1)+0.9343*M(5)-0.8776*E(7))*E(7)*0.7
11715 LET T(8)=(0.7517*W(2,1)+0.9343*M(5)-0.8776*E(8))*E(8)*0.7
11720 LET U(8)=(2.5942*W(2,1)+1.5865*M(5)-3.8199*E(9))*E(9)

```

```

11725 LET V(8)=S(8)+T(8)+U(8)
11730 LET V(5)=E(7)*(95.2023-4.5476*L(1,1)+0.7604*M(6))
11735 LET V(5)=V(5)+E(8)*(5.702*L(1,1)+1.699*M(7))
11740 LET V(5)=V(5)+E(9)*(6.740*L(1,1)+1.1016*M(8)+25.213)
11745 LET V(5)=Q*(V(5)+V(8))
11750 LET H(J)=H(J)+V(9)+V(5)
11755 FOR M=1 TO 4
11760 LET V(M)=V(M)+V(9)
11765 NEXT M
11770 IF H(J)=0 THEN 11790
11775 IF D(7,J) <> 0 THEN 11795
11780 LET Y$(J)=L$
11785 GO TO 11795
11790 LET Y$(J)=K$
11795 IF P <> 1 THEN 11935
11800 LET B(7)=(B(1)+B(2)+B(3)+B(4)+B(5)+B(6))/6
11805 IF V(1)=0 THEN 11820
11810 LET V(6)=(V(1)+V(2)+V(2)+V(3)+V(4))/4+V(5)
11815 GO TO 11825
11820 LET V(6)=(V(2)+V(3)+V(4))/3+V(5)
11825 LET P2=1.16-0.0003*D(2,J)+0.0015*D(7,J)
11830 IF P2 < 1.1 THEN 11850
11835 IF P2 < 1.5 THEN 11855
11840 LET P2=1.5
11845 GO TO 11855
11850 LET P2=1.1
11855 LET P3=P2*B(7)
11860 LET P4=P2*V(6)
11865 PRINT
11870 LET P5=P3+P4
11875 PRINT
11880 PRINT USING 11885,Q$(1)
11885:'CCCCCCCCCCCCCCCCCCCCCCCCCCCCCCCCCCCCCCCCCCCCCCCCCCCCCCCC
11890 PRINT
11895 PRINT "WALL COST", "TRIM COST", "TOTAL COST", "MARKUP RATIO"
11900 PRINT P3,P4,P5,P2
11905 PRINT
11910 PRINT
11915 PRINT "IF YOU WISH TO DO MORE COST ESTIMATES TYPE 1, IF NOT TYPE 0"
11920 INPUT P6
11925 IF P6=1 THEN 10355
11930 GO TO 13300
11935 REM F IS BASIC DATA MATRIX
11940 LET F(J,1)=C(J)+H(J)
11945 LET F(J,2)=D(2,J)
11950 LET F(J,3)=D(7,J)
11955 IF Z$(J)=P$(J) THEN 11970
11960 LET F(J,4)=0
11965 GO TO 11975
11970 LET F(J,4)=D(2,J)
11975 LET F(J,5)=C(J)

```

```

11980 LET F(J,6)=G(J)
11985 LET F(J,7)=G(J)-C(J)
11990 NEXT J
11995 LET F1=0
12000 AT Y=ZER(N,10)
12005 MAT Y=F
12010 IF N<>1 THEN 12025
12015 LET Y(1,8)=1
12020 GO TO 12490
12025 REM PAIR DWELLING UNITS
12030 REM L IS DIFFERENTIAL MARKUP MATRIX
12035 MAT L=ZER(N,N)
12040 FOR I=1 TO N
12045 FOR K=1 TO N
12050 IF Y(I,2)<>0 THEN 12070
12055 IF Y(K,2)<>0 THEN 12070
12060 LET L(I,K)=10
12065 GO TO 12075
12070 LET L(I,K)=-0.000079*Y(I,2)+0.00052*Y(I,3)-0.2144*(Y(I,4)/(Y(I,2)+Y(K,2)))
12075 NEXT K
12080 NEXT I
12085 FOR I=1 TO N
12090 LET L(I,I)=9
12095 NEXT I
12100 REM P IS DIRECT COST MATRIX
12105 MAT P=ZER(N,N)
12110 FOR J=1 TO N
12115 LET P(J,J)=Y(J,1)
12120 NEXT J
12125 REM D IS TEST MATRIX
12130 MAT D=ZER(N,N)
12135 MAT D=L*P
12140 REM W IS TRIANGULAR TEST MATRIX
12145 MAT W=ZER(N,N)
12150 FOR K=1 TO N-1
12155 LET I=K+1
12160 LET W(I,K)=D(I,K)+D(K,I)
12165 LET I=I+1
12170 IF I<N THEN 12160
12175 NEXT K
12180 LET N1=N*(N-1)/2
12185 MAT X=ZER(N1,3)
12190 LET J=1
12195 FOR K=1 TO N-1
12200 LET I=K+1
12205 LET X(J,1)=W(I,K)
12210 LET X(J,2)=I
12215 LET X(J,3)=K
12220 IF J>=N1 THEN 12250
12225 LET I=I+1
12230 LET J=J+1

```

```

12235 IF I>N THEN 12245
12240 GO TO 12205
12245 NEXT K
12250 REM SORT X MATRIX
12255 FOR L=1 TO N1-1
12260 FOR M=1 TO N1-1
12265 LET Q1=X(M,1)
12270 LET Q2=X(M+1,1)
12275 LET R1=X(M,2)
12280 LET R2=X(M+1,2)
12285 LET S1=X(M,3)
12290 LET S2=X(M+1,3)
12295 IF Q1<=Q2 THEN 12330
12300 LET X(M,1)=Q2
12305 LET X(M+1,1)=Q1
12310 LET X(M,2)=R2
12315 LET X(M+1,2)=R1
12320 LET X(M,3)=S2
12325 LET X(M+1,3)=S1
12330 NEXT M
12335 NEXT L
12340 IF F1=1 THEN 12545
12345 REM Y IS PRELIMINARY CONTRACT PACKAGE MATRIX
12350 LET J=1
12355 LET K=1
12360 LET B2=X(J,2)
12365 LET B3=X(J,3)
12370 IF F(B2,10)=1 THEN 12430
12375 IF F(B3,10)=1 THEN 12430
12380 FOR M=1 TO 7
12385 LET Y(K,M)=F(B2,M)+F(B3,M)
12390 NEXT M
12395 LET Y(K,8)=B2
12400 LET Y(K,9)=B3
12405 LET F(B2,10)=1
12410 LET F(B3,10)=1
12415 IF K=N2 THEN 12490
12420 IF K=N3 THEN 12440
12425 LET K=K+1
12430 LET J=J+1
12435 GO TO 12360
12440 LET K=K+1
12445 FOR I=1 TO N
12450 IF F(I,10)=0 THEN 12460
12455 NEXT I
12460 LET B2=I
12465 FOR M=1 TO 7
12470 LET Y(K,M)=F(B2,M)
12475 NEXT M
12480 LET Y(K,8)=B2
12485 LET Y(K,9)=0

```

```

12490 IF N>2 THEN 12530
12495 LET N6=1
12500 FOR M=1 TO 7
12505 LET Z(1,M)=Y(1,M)
12510 NEXT M
12515 LET Z(1,8)=1
12520 LET Z(1,9)=0
12525 GO TO 12935
12530 LET F1=1
12535 LET N=K
12540 GO TO 12025
12545 REM Z IS FINAL CONTRACT PACKAGE MATRIX
12550 LET J=1
12555 LET K=1
12560 IF INT(N/2)=N/2 THEN 12580
12565 LET N4=(N+1)/2
12570 LET N5=N4-1
12575 GO TO 12590
12580 LET N4=N/2
12585 LET N5=N4
12590 FOR J=1 TO (N-1)*N/2
12595 IF X(J,1)>0 THEN 12685
12600 LET B2=X(J,2)
12605 LET B3=X(J,3)
12610 IF Y(B2,10)=1 THEN 12670
12615 IF Y(B3,10)=1 THEN 12670
12620 FOR M=1 TO 7
12625 LET Z(K,M)=Y(B2,M)+Y(B3,M)
12630 NEXT M
12635 LET Z(K,8)=B2
12640 LET Z(K,9)=B3
12645 LET Y(B2,10)=1
12650 LET Y(B3,10)=1
12655 IF K=N4 THEN 12930
12660 IF K=N5 THEN 12680
12665 LET K=K+1
12670 NEXT J
12675 GO TO 12685
12680 LET K=K+1
12685 IF N2=N3 THEN 12805
12690 FOR I=1 TO N
12695 IF Y(I,9)=0 THEN 12705
12700 NEXT I
12705 IF Y(I,10)=1 THEN 12790
12710 LET B2=I
12715 LET N1=N*(N-1)/2
12720 FOR I=1 TO N1
12725 IF X(I,2)=B2 THEN 12740
12730 IF X(I,3)=B2 THEN 12750
12735 NEXT I
12740 LET B3=X(I,3)

```

```

12745 GO TO 12755
12750 LET B3=X(I,2)
12755 IF Y (B3,10)=1 THEN 12880
12760 FOR M=1 TO 7
12765 LET Z(K,M)=Y(B2,M)+Y(B3,M)
12770 NEXT M
12775 LET Z(K,8)=B3
12780 LET Z(K,9)=B2
12785 LET Y(B2,10)=1
12790 LET Y(B3,10)=1
12795 IF K=N4 THEN 12805
12800 LET K=K+1
12805 FOR I=1 TO N
12810 IF Y(I,10)=1 THEN 12870
12815 FOR M=1 TO 7
12820 LET Z(K,M)=Y(I,M)
12825 NEXT M
12830 LET Z(K,8)=I
12835 LET Z(K,9)=0
12840 LET Y(I,10)=1
12845 FOR L=1 TO N
12850 IF Y(L,10)=0 THEN 12865
12855 NEXT L
12860 GO TO 12875
12865 LET K=K+1
12870 NEXT I
12875 GO TO 12930
12880 FOR I=1 TO N
12885 IF Z(I,8)=B3 THEN 12900
12890 IF Z(I,9)=B3 THEN 12900
12895 NEXT I
12900 LET Z(I,10)=B2
12905 FOR M=1 TO 7
12910 LET Z(I,M)=Z(I,M)+Y(B2,M)
12915 NEXT M
12920 LET Y(B2,10)=1
12925 GO TO 12805
12930 LET N6=K
12935 MAT W=ZER(N6,5)
12940 FOR K=1 TO N6
12945 LET Z8=Z(K,8)
12950 LET W(K,1)=Y(Z8,8)
12955 LET W(K,2)=Y(Z8,9)
12960 IF Z(K,9)=0 THEN 12995
12965 LET Z9=Z(K,9)
12970 LET W(K,3)=Y(Z9,8)
12975 LET W(K,4)=Y(Z9,9)
12980 LET Z9=Z(K,10)
12985 IF Z9=0 THEN 12995
12990 LET W(K,5)=Y(Z9,8)
12995 NEXT K

```

```

13000 FOR K=1 TO N6
13005 PRINT
13010 PRINT
13015 PRINT "
CONTRACT "K
13020 PRINT
13025 LET I=1
13030 LET M(K)=-0.000079*Z(K,2)+0.00052*Z(K,3)-0.2144*(Z(K,4)/Z(K,2))
13035 LET M(K)=M(K)+1.2972
13040 REM W5 IS DWELLING UNIT NUMBER
13045 LET W5=W(K,I)
13050 IF W5<>0 THEN 13075
13055 LET I=I+1
13060 IF I>5 THEN 13165
13065 IF W(K,I)=0 THEN 13165
13070 LET W5=W(K,I)
13075 IF F(W5,2)=0 THEN 13120
13080 LET M9=-0.2144*(F(W5,4))/Z(K,2)
13085 LET M8=M9*Z(K,1)+M(K)*F(W5,7)
13090 IF M8>=0 THEN 13120
13095 LET M(K)=M(K)+M9
13100 LET Z$(W5)=P$(W5)
13105 LET F(W5,1)=F(W5,1)+F(W5,7)
13110 LET Z(K,1)=Z(K,1)+F(W5,7)
13115 LET Z(K,4)=Z(K,4)+F(W5,4)
13120 PRINT " DWELLING UNIT "W5,Q$(W5)
13125 PRINT
13130 PRINT " WALL TECHNIQUE "Z$(W5)
13135 PRINT " TRIM TECHNIQUE "Y$(W5)
13140 PRINT " DIRECT COST $"F(W5,1)
13145 PRINT
13150 IF W5=0 THEN 13165
13155 LET I=I+1
13160 IF I<=5 THEN 13045
13165 IF M(K)<1.1 THEN 13185
13170 IF M(K)<=1.5 THEN 13190
13175 LET M(K)=1.5
13180 GO TO 13190
13185 LET M(K)=1.1
13190 LET Z(K,1)=M(K)*Z(K,1)
13195 PRINT " CONTRACT PRICE $"Z(K,1)
13200 PRINT " MARKUP RATIO "M(K)
13205 PRINT
13210 IF Q=0 THEN 13205
13215 PRINT "THIS INCLUDES THE COMPONENT REPLACEMENT YOU REQUESTED"
13220 NEXT K
13225 PRINT "IF YOU WISH TO DO MORE COST ESTIMATES TYPE 1, IF NOT TYPE 0"
13230 INPUT Q7
13235 IF Q7=0 THEN 13300
13240 RESTORE #1
13245 RESTORE #2
13250 RESTORE #3
13255 MAT W=ZER(6,1)
13260 MAT L=ZER(7,1)
13265 MAT READ #1,W
13270 MAT READ #3,L
13275 FOR L=1 TO 5
13280 READ #2,M(L)
13285 NEXT L
13290 MAT D=ZER(10,10)
13295 GO TO 10295
13300 END

```



## REFERENCES

- Boeing Aerospace Company, Experimental Hazard Elimination Program Dwelling Unit Report: Phase II, Part II B General Data, December 1976, (unpublished report).
- Boone, Thomas H., Harvey W. Berger, A. Philip Cramp, Herbert A. Jackson, The Demonstration of Experimental Lead Paint Hazard Abatement Methods in Washington, D.C., National Bureau of Standards, Interagency Report 75-761, June 1975.
- Boone, Thomas H., Harvey W. Berger, A. Philip Cramp, Herbert A. Jackson, The Demonstration of Experimental Lead Paint Hazard Abatement Methods in Atlanta, Georgia, National Bureau of Standards, Interagency Report 75-974, December 1975.
- Brownlee, K. A., Statistical Theory and Methodology in Science and Engineering, John Wiley and Sons, Inc., New York, 1960.
- Chapman, Robert E., Economic Analysis of Experimental Lead Paint Abatement Methods: Phase I, National Bureau of Standards, Technical Note 922, September 1976.
- Chapman, Robert E. and Joseph G. Kowalski, Guidelines for Cost-Effective Lead Paint Abatement, National Bureau of Standards, Technical Note 1971, (in press).
- Dixon, W. J. and F. J. Massey, Introduction to Statistical Analysis, McGraw-Hill Book Company, New York, 1957.
- Draper, N. R. and H. Smith, Applied Regression Analysis, John Wiley and Sons, Inc., New York, 1966.
- Fisz, Marek, Probability Theory and Mathematical Statistics, Third Edition, John Wiley and Sons, Inc., New York, 1963.
- Godfrey, Robert S., ed., Building Construction Cost Data, 1977, Robert S. Means, Inc., Duxbury, Massachusetts, 1976.
- Hogben, David, Sally T. Peavy, Ruth N. Varner, OMNITAB II User's Reference Manual, National Bureau of Standards, Technical Note 552, October 1971.
- Johnston, J., Econometric Methods, Second Edition, McGraw-Hill Book Company, New York, 1972.
- Musgrave, Gerald L. and Robert H. Rasche, "Estimation of Cost Functions," The Engineering Economist, Volume 22, Number 3, Spring 1977.

- Natrella, Mary, Experimental Statistics, National Bureau of Standards, Handbook 91, August 1963.
- Scheffe, H., The Analysis of Variance, John Wiley and Sons, Inc., New York, 1959.
- Shier, Douglas R. and William G. Hall, Analysis of Housing Data Collected in a Lead-Based Paint Survey in Pittsburgh, Pennsylvania Part I, National Bureau of Standards, Interagency Report 77-1250, May 1977.
- Shier, Douglas R. and William G. Hall, Analysis of Housing Data Collected in a Lead-Based Paint Survey in Pittsburgh, Pennsylvania Part II, National Bureau of Standards, Interagency Report 77-1293, June 1977.
- Snedecor, G. W., Statistical Methods, Fifth Edition, Iowa State University Press, 1956.
- U.S. Bureau of the Census, Census of Housing: 1970 Detailed Housing Characteristics Final Report HC(1)-B1, United States Summary, Table 22.
- U.S. Bureau of the Census, Census of Housing: 1970 Metropolitan Housing Characteristics Final Report HC, United States Summary, Table B-6.
- U.S. Bureau of the Census, Statistical Abstracts of the United States: 1976, U.S. Department of Commerce, 97th ed., July 1976.

|   |  |   |  |                              |
|---|--|---|--|------------------------------|
| U.S. DEPT. OF COMM.<br>BIBLIOGRAPHIC DATA<br>SHEET  |  | 1. PUBLICATION OR REPORT NO.<br>NBS TN 979              | 2. Gov't Accession<br>No.              | 3. Recipient's Accession No. |
| 4. TITLE AND SUBTITLE<br>LEAD PAINT ABATEMENT COSTS: SOME TECHNICAL<br>AND THEORETICAL CONSIDERATIONS   |  |   | 5. Publication Date<br>February 1979   |                              |
|   |  |   | 6. Performing Organization Code        |                              |
| 7. AUTHOR(S)<br>Robert E. Chapman and Joseph G. Kowalski  |  |   | 8. Performing Organ. Report No.        |                              |
| 9. PERFORMING ORGANIZATION NAME AND ADDRESS<br><br>NATIONAL BUREAU OF STANDARDS<br>DEPARTMENT OF COMMERCE<br>WASHINGTON, D.C. 20234   |  |   | 10. Project/Task/Work Unit No.         |                              |
|   |  |   | 11. Contract/Grant No.                 |                              |
| 12. Sponsoring Organization Name and Complete Address (Street, City, State, ZIP)<br>Office of Policy Development and Research<br>Department of Housing and Urban Development<br>Washington, D.C. 20410  |  |   | 13. Type of Report & Period<br>Covered |                              |
|   |  |   | 14. Sponsoring Agency Code             |                              |
| 15. SUPPLEMENTARY NOTES   |  |   |  |                              |
| 16. ABSTRACT (A 200-word or less factual summary of most significant information. If document includes a significant bibliography or literature survey, mention it here.)<br><br>Public and private concern about the potential for lead poisoning in children due to the ingestion of lead-based paint chips has resulted in a Federally sponsored program to develop technologies by which the lead-based paint hazard may be eliminated from the nation's housing. The nature and design of the Experimental Hazard Elimination Program (EHEP) is thought to be unique in that it permitted the costs of the alternative lead paint abatement techniques to be rigorously analyzed. The focus of this report is on the design, implementation and analysis of EHEP and the cost information it produced. Statistical analyses which permitted the development of econometric models capable of estimating abatement technique costs and expected contractor markup are described. Structural equations relating changes in the values of certain key factors to variations in direct cost and contractor markup are also presented. Guidelines, including a national deleading cost estimate, are given so that these econometric models can be used by municipal officials and building owners to estimate deleading costs as well as provide input to policy evaluation and formulation. |  |   |  |                              |
| 17. KEY WORDS (six to twelve entries; alphabetical order; capitalize only the first letter of the first key word unless a proper name; separated by semicolons)<br><br>Abatement; building economics; building materials; cost estimation; econometric models; economic analysis; housing; lead-based paint; lead poisoning.  |  |   |  |                              |
| 18. AVAILABILITY<br><input checked="" type="checkbox"/> Unlimited<br><br><input type="checkbox"/> For Official Distribution. Do Not Release to NTIS<br><br><input checked="" type="checkbox"/> Order From Sup. of Doc., U.S. Government Printing Office<br>Washington, D.C. 20402, SD Stock No. SN003-003/<br><br><input type="checkbox"/> Order From National Technical Information Service (NTIS)<br>Springfield, Virginia 22151  |  | 19. SECURITY CLASS<br>(THIS REPORT)<br><br>UNCLASSIFIED |  | 21. NO. OF PAGES<br><br>153  |
|   |  | 20. SECURITY CLASS<br>(THIS PAGE)<br><br>UNCLASSIFIED   |  | 22. Price<br><br>\$3.25      |



# JOURNAL OF RESEARCH

of the National Bureau of Standards

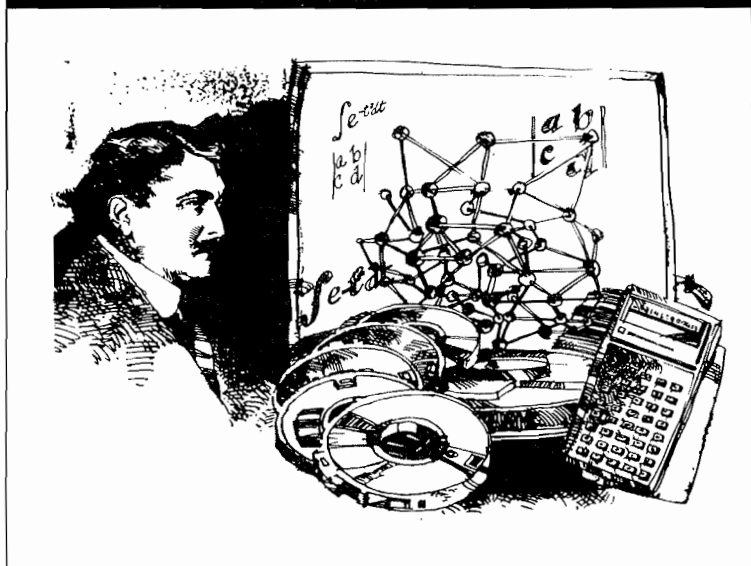

# Subscribe now — The new National Bureau of Standards Journal

The expanded Journal of Research of the National Bureau of Standards reports NBS research and development in those disciplines of the physical and engineering sciences in which the Bureau is active. These include physics, chemistry, engineering, mathematics, and computer sciences. Papers cover a broad range of subjects, with major emphasis on measurement methodology, and the basic technology underlying standardization. Also included from time to time are survey articles on topics closely related to the Bureau's technical and scientific programs. As a special service to subscribers each issue contains complete citations to all recent NBS publications in NBS and non-NBS media. Issued six times a year. Annual subscription: domestic \$17.00; foreign \$21.25. Single copy, \$3.00 domestic; \$3.75 foreign.

- Note: The Journal was formerly published in two sections: Section A "Physics and Chemistry" and Section B "Mathematical Sciences."

NBS Board of Editors  
Churchill Eisenhart,  
Executive Editor (Mathematics)  
John W. Cooper (Physics)  
Donald D. Wagman (Chemistry)  
Andrew J. Fowell (Engineering)  
Joseph O. Harrison (Computer Science)  
Helmut W. Hellwig (Boulder Labs.)

For a review copy, write Journal of Research, National Bureau of Standards, U.S. DEPARTMENT OF COMMERCE Washington, D.C. 20234

## Subscription Order Form

Enter my subscription to NBS Journal of Research at \$17.00. Add \$4.25 for foreign mailing. No additional postage is required for mailing within the United States or its possessions. (SJR—File Code 2Q)

Send Subscription to:

|   |  |  |  |       |  |  |  |          |  |  |  |
|---|--|--|--|-------|--|--|--|----------|--|--|--|
| Name-First, Last                        |  |  |  |       |  |  |  |          |  |  |  |
| Company Name or Additional Address Line |  |  |  |       |  |  |  |          |  |  |  |
| Street Address                          |  |  |  |       |  |  |  |          |  |  |  |
| City                                    |  |  |  | State |  |  |  | Zip Code |  |  |  |

- Remittance Enclosed  
(Make checks payable to Superintendent of Documents)
- Charge to my Deposit Account No.

MAIL ORDER FORM TO:  
Superintendent of Documents  
Government Printing Office  
Washington, D.C. 20402



# NBS TECHNICAL PUBLICATIONS

## PERIODICALS

**JOURNAL OF RESEARCH**—The Journal of Research of the National Bureau of Standards reports NBS research and development in those disciplines of the physical and engineering sciences in which the Bureau is active. These include physics, chemistry, engineering, mathematics, and computer sciences. Papers cover a broad range of subjects, with major emphasis on measurement methodology, and the basic technology underlying standardization. Also included from time to time are survey articles on topics closely related to the Bureau's technical and scientific programs. As a special service to subscribers each issue contains complete citations to all recent NBS publications in NBS and non-NBS media. Issued six times a year. Annual subscription: domestic \$17.00; foreign \$21.25. Single copy, \$3.00 domestic; \$3.75 foreign.

Note: The Journal was formerly published in two sections: Section A "Physics and Chemistry" and Section B "Mathematical Sciences."

### DIMENSIONS/NBS

This monthly magazine is published to inform scientists, engineers, businessmen, industry, teachers, students, and consumers of the latest advances in science and technology, with primary emphasis on the work at NBS. The magazine highlights and reviews such issues as energy research, fire protection, building technology, metric conversion, pollution abatement, health and safety, and consumer product performance. In addition, it reports the results of Bureau programs in measurement standards and techniques, properties of matter and materials, engineering standards and services, instrumentation, and automatic data processing.

Annual subscription: Domestic, \$11.00; Foreign \$13.75

## NONPERIODICALS

**Monographs**—Major contributions to the technical literature on various subjects related to the Bureau's scientific and technical activities.

**Handbooks**—Recommended codes of engineering and industrial practice (including safety codes) developed in cooperation with interested industries, professional organizations, and regulatory bodies.

**Special Publications**—Include proceedings of conferences sponsored by NBS, NBS annual reports, and other special publications appropriate to this grouping such as wall charts, pocket cards, and bibliographies.

**Applied Mathematics Series**—Mathematical tables, manuals, and studies of special interest to physicists, engineers, chemists, biologists, mathematicians, computer programmers, and others engaged in scientific and technical work.

**National Standard Reference Data Series**—Provides quantitative data on the physical and chemical properties of materials, compiled from the world's literature and critically evaluated. Developed under a world-wide program coordinated by NBS. Program under authority of National Standard Data Act (Public Law 90-396).

NOTE: At present the principal publication outlet for these data is the Journal of Physical and Chemical Reference Data (JPCRD) published quarterly for NBS by the American Chemical Society (ACS) and the American Institute of Physics (AIP). Subscriptions, reprints, and supplements available from ACS, 1155 Sixteenth St. N.W., Wash., D.C. 20056.

**Building Science Series**—Disseminates technical information developed at the Bureau on building materials, components, systems, and whole structures. The series presents research results, test methods, and performance criteria related to the structural and environmental functions and the durability and safety characteristics of building elements and systems.

**Technical Notes**—Studies or reports which are complete in themselves but restrictive in their treatment of a subject. Analogous to monographs but not so comprehensive in scope or definitive in treatment of the subject area. Often serve as a vehicle for final reports of work performed at NBS under the sponsorship of other government agencies.

**Voluntary Product Standards**—Developed under procedures published by the Department of Commerce in Part 10, Title 15, of the Code of Federal Regulations. The purpose of the standards is to establish nationally recognized requirements for products, and to provide all concerned interests with a basis for common understanding of the characteristics of the products. NBS administers this program as a supplement to the activities of the private sector standardizing organizations.

**Consumer Information Series**—Practical information, based on NBS research and experience, covering areas of interest to the consumer. Easily understandable language and illustrations provide useful background knowledge for shopping in today's technological marketplace.

Order above NBS publications from: Superintendent of Documents, Government Printing Office, Washington, D.C. 20402.

Order following NBS publications—NBSIR's and FIPS from the National Technical Information Services, Springfield, Va. 22161.

**Federal Information Processing Standards Publications (FIPS PUB)**—Publications in this series collectively constitute the Federal Information Processing Standards Register. Register serves as the official source of information in the Federal Government regarding standards issued by NBS pursuant to the Federal Property and Administrative Services Act of 1949 as amended, Public Law 89-306 (79 Stat. 1127), and as implemented by Executive Order 11717 (38 FR 12315, dated May 11, 1973) and Part 6 of Title 15 CFR (Code of Federal Regulations).

**NBS Interagency Reports (NBSIR)**—A special series of interim or final reports on work performed by NBS for outside sponsors (both government and non-government). In general, initial distribution is handled by the sponsor; public distribution is by the National Technical Information Services (Springfield, Va. 22161) in paper copy or microfiche form.

## BIBLIOGRAPHIC SUBSCRIPTION SERVICES

The following current-awareness and literature-survey bibliographies are issued periodically by the Bureau:

**Cryogenic Data Center Current Awareness Service.** A literature survey issued biweekly. Annual subscription: Domestic, \$25.00; Foreign, \$30.00.

**Liquefied Natural Gas.** A literature survey issued quarterly. Annual subscription: \$20.00.

**Superconducting Devices and Materials.** A literature survey issued quarterly. Annual subscription: \$30.00. Send subscription orders and remittances for the preceding bibliographic services to National Bureau of Standards, Cryogenic Data Center (275.02) Boulder, Colorado 80302.

U.S. DEPARTMENT OF COMMERCE  
National Bureau of Standards  
Washington, D.C. 20234

OFFICIAL BUSINESS

Penalty for Private Use, \$300

FILE COPY

POSTAGE AND FEES PAID  
U.S. DEPARTMENT OF COMMERCE  
COM-215



SPECIAL FOURTH-CLASS RATE  
BOOK

---