

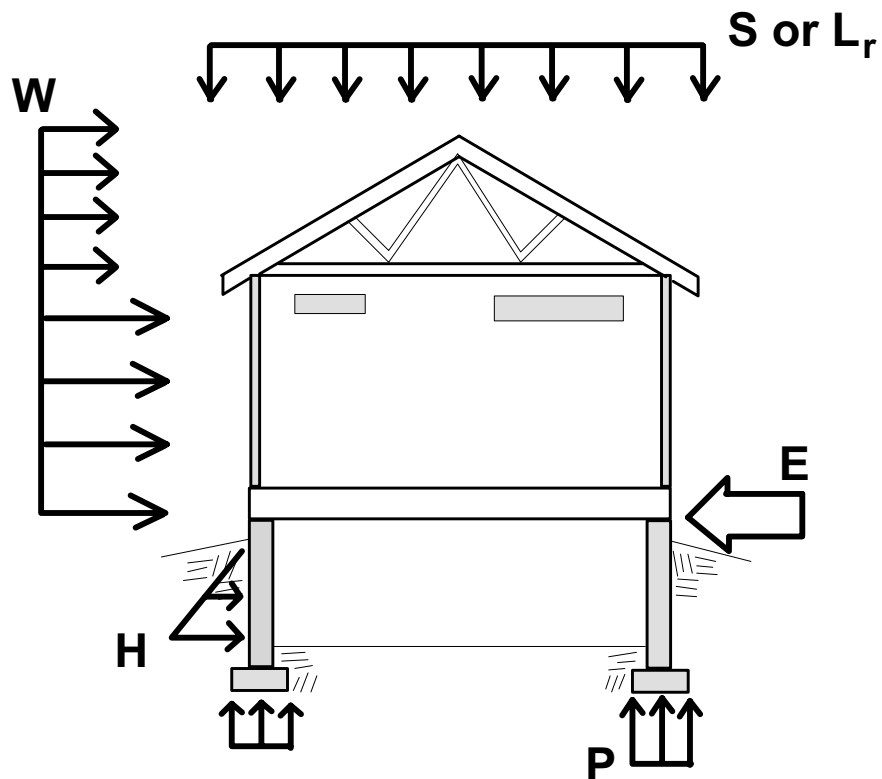

U.S. Department of Housing and Urban Development  
Office of Policy Development and Research

# ***Structural Design Loads for One- and Two-Family Dwellings***



PATH (Partnership for Advancing Technology in Housing) is a new private/public effort to develop, demonstrate, and gain widespread market acceptance for the “Next Generation” of American housing. Through the use of new or innovative technologies, the goal of PATH is to improve the quality, durability, environmental efficiency, and affordability of tomorrow’s homes.

PATH, initiated jointly by the Administration and Congress, is managed and supported by the Department of Housing and Urban Development (HUD). In addition, all Federal Agencies that engage in housing research and technology development are PATH Partners, including the Departments of Energy and Commerce, as well as the Environmental Protection Agency (EPA) and the Federal Emergency Management Agency (FEMA). State and local governments and other participants from the public sector are also partners in PATH. Product manufacturers, home builders, insurance companies, and lenders represent private industry in the PATH Partnership.

To learn more about PATH, please contact:



451 7th Street, SW  
Suite B 133  
Washington, DC 20410  
202-708-5873 (fax)  
e-mail: [pathnet@pathnet.org](mailto:pathnet@pathnet.org)  
website: [www.pathnet.org](http://www.pathnet.org)

Visit PD&R's Web Site

**[www.huduser.org](http://www.huduser.org)**

to find this report and others sponsored by  
HUD's Office of Policy Development and Research (PD&R).

Other services of HUD USER, PD&R's Research Information Service, include listservs; special interest, bimonthly publications (best practices, significant studies from other sources); access to public use databases; hotline 1-800-245-2691 for help accessing the information you need.

# ***Structural Design Loads for One- and Two-Family Dwellings***

Prepared for

U.S. Department of Housing and Urban Development  
Office of Policy Development and Research  
Washington, DC

Contract H-21172CA

and

National Association of Home Builders  
*Program for Research and Optimum Value Engineering*  
Washington, DC

by

NAHB Research Center, Inc.  
Upper Marlboro, Maryland

May 2001

# Acknowledgments

This document was prepared by the NAHB Research Center, Inc. The work was cooperatively sponsored by the U.S. Department of Housing and Urban Development (HUD) and the National Association of Home Builders (NAHB). Appreciation is extended to the following individuals whose comments and critical review served to improve this work:

Eric Burnett, Ph.D., Director, Pennsylvania Housing Research Center (Penn State University)  
Helen English, Executive Director, Sustainable Buildings Industry Council  
William Freeborne, U.S. Department of Housing and Urban Development  
Lee Golanoski, Assistant Director of Architecture, Toll Brothers, Inc.  
Peter L. Pfeiffer, Principal, Barley and Pfeiffer Architects  
David V. Rosowsky, Ph.D., Oregon State University  
Jim Rossberg, American Society of Civil Engineers  
Andrea Vrankar, PE, RA, U.S. Department of Housing and Urban Development

## NOTICE

The work that provided the basis for this publication was supported by funding under a grant with the U.S. Department of Housing and Urban Development. The substance and findings of the work are dedicated to the public. The author is solely responsible for the accuracy of the statements and interpretations contained in this publication. Such interpretations do not necessarily reflect the views of the Government.

While the information in this document is believed to be accurate, neither the authors, nor reviewers, nor the U.S. Department of Housing and Urban Development, nor the NAHB Research Center, Inc., nor any of their employees or representatives makes any warranty, guarantee, or representation, expressed or implied, with respect to the accuracy, effectiveness, or usefulness of any information, method, or material in this document, nor assumes any liability for the use of any information, methods, or materials disclosed herein, or for damages arising from such use. This publication is intended for use by professionals who are competent to evaluate the significance and limitations of the reported information.

## ABOUT THE NAHB RESEARCH CENTER, INC.

The NAHB Research Center is a not-for-profit subsidiary of the National Association of Home Builders (NAHB). The NAHB has 200,000 members, including 50,000 builders who build more than 80 percent of new American homes. NAHB Research Center conducts research, analysis, and demonstration programs in all areas relating to home building and carries out extensive programs of information dissemination and interchange among members of the industry and between the industry and the public.

# Preface

---

This guide serves the express purpose of promoting a practical and technically sound method of determining design loads for typical residential construction in the United States. The scope, therefore, is limited to single-family attached and detached buildings. It is intended to advance residential building design by unifying the current practice of applying design loads, improving the level of efficiency in the design effort, and promoting cost-effective results. Therefore, this guide serves as a resource document for residential building designers and as a simple model for reasonable determination of design loads for low-rise residential buildings.

*Structural Design Loads for One- and Two-Family Dwellings* is based on a compilation and simplification of best practices for the design and construction of homes in the United States. It is intended to supplement current standards of design such as found in national model building codes and design standards such as *Minimum Design Loads for Buildings and Other Structures (ASCE 7-98)*<sup>1</sup>. The scope of current standards of design typically encompass such a breadth of applications that it is often difficult for designers to make simple and effective applications to residential buildings. Similarly, unique technical considerations on design loads for housing are often overlooked in generalized design criteria.

This guide is based on current practices as represented in ASCE 7-98, but it also contains relevant technical information from newer resources such as the *Residential Structural Design Guide*<sup>2</sup> as well as older resources such as *ANSI A58.1*<sup>3</sup>, the *Minimum Property Standards*<sup>4</sup>, and *Light Frame House Construction*<sup>5</sup>. International methods of determining residential design loads were also considered, such as *Wind Loads for Housing*<sup>6</sup> and *Residential Timber-Framed Construction, Part 1 Design Criteria*<sup>7</sup>.

While this document is written in a “regulatory style,” it is not a consensus standard that is currently referenced in any existing local, state, or national model building code in the United States. Therefore, the designer is encouraged to become fully aware of any potential differences from local regulations prior to considering the use of this guide as an alternate means or method of design.

---

<sup>1</sup>*Minimum Design Loads for Buildings and Other Structures*, ASCE Standard 7-98, American Society of Civil Engineers, Reston, VA, 1999.

<sup>2</sup>*Residential Structural Design Guide: 2000 Edition*, prepared for the U.S. Department of Housing and Urban Development by NAHB Research Center, Inc., Upper Marlboro, MD, 2000.

<sup>3</sup>*Minimum Design Loads for Buildings and Other Structures*, ANSI A58.1, American National Standards Institute, New York, NY, 1982.

<sup>4</sup>*Minimum Property Standards*, Federal Housing Administration, Washington, DC, 1958.

<sup>5</sup>*Light Frame House Construction*, U.S. Department of Health, Education, and Welfare, Washington, DC, 1931 (reprinted 1956).

<sup>6</sup>*Wind Loads for Housing*, AS 4055—1992, Standards Australia, Homebush, NSW 2140.

<sup>7</sup>*Residential Timber-Framed Construction, Part 1 Design Criteria*, AS 1684.1—1999, Standards Australia International, Strathfield, NSW 2135.



# Table of Contents

|  | <b>Page</b> |
|--|-------------|
| PREFACE .....                          | iii         |
| 1. GENERAL .....                       | 1           |
| 1.1 Scope .....                        | 1           |
| 1.2 Purpose .....                      | 1           |
| 1.3 Definitions .....                  | 1           |
| 1.4 Symbols and Units .....            | 5           |
| 1.5 Basic Design Criteria .....        | 6           |
| 2. LOAD COMBINATIONS .....             | 10          |
| 2.1 General .....                      | 10          |
| 2.2 Load Reductions .....              | 11          |
| 2.3 Increase in Allowable Stress ..... | 11          |
| 3. DEAD LOAD (D) .....                 | 11          |
| 4. LIVE LOAD (L) .....                 | 12          |
| 4.1 General .....                      | 12          |
| 4.2 Concentrated Loads .....           | 13          |
| 4.3 Minimum Attic Load .....           | 13          |
| 4.4 Live Load Reduction .....          | 13          |
| 4.5 Unusual Live Loads .....           | 14          |
| 5. SOIL LATERAL LOAD (H) .....         | 14          |
| 5.1 General .....                      | 14          |
| 5.2 Equivalent Fluid Density .....     | 14          |
| 5.3 Lateral Soil Pressure .....        | 15          |
| 5.4 Flood Loads .....                  | 16          |
| 5.5 Expansive Soils .....              | 16          |
| 5.6 Frost Protection .....             | 16          |
| 6. WIND LOAD (W) .....                 | 17          |
| 6.1 General .....                      | 17          |
| 6.2 Basic Wind Speed .....             | 17          |
| 6.3 Wind Exposure .....                | 17          |
| 6.4 Basic Velocity Pressure .....      | 18          |

|     |   |    |
|-----|---|----|
| 6.5 | Lateral Wind Loads on Whole Building .....                        | 19 |
| 6.6 | Wind Loads on Components, Claddings, and Various Assemblies ..... | 20 |
| 6.7 | Internal Pressure .....   | 21 |
| 6.8 | Overtopping Forces .....  | 21 |
| 6.9 | Wind-borne Debris Protection .....                                | 21 |
| 7.  | SNOW LOAD (S) .....   | 23 |
| 7.1 | Ground Snow Load .....  | 23 |
| 7.2 | Roof Snow Load .....  | 23 |
| 7.3 | Off-Balance Snow Load .....                                       | 23 |
| 8.  | EARTHQUAKE LOAD (E) .....   | 24 |
| 8.1 | General .....   | 24 |
| 8.2 | Design Ground Motion .....  | 24 |
| 8.3 | Seismic Shear Load .....  | 24 |
| 8.4 | Distribution of Story Shear Load .....                            | 25 |
| 8.5 | Vertical Seismic Forces .....                                     | 25 |

APPENDIX A - DESIGN DATA

APPENDIX B - SUPPLEMENTAL DESIGN REFERENCES

APPENDIX C - METRIC CONVERSION FACTORS



# List of Tables

|              |   |    |
|--------------|---|----|
| Table 2.1    | Generalized Load Combinations.....  | 10 |
| Table 2.2    | Load Combinations Typically Used for the Design of Residential Building Components and Systems..... | 10 |
| Table 3.0a   | Typical Dead Loads for Common Residential Constructions.....  | 11 |
| Table 3.0b   | Densities for Common Residential Construction Materials.....  | 12 |
| Table 4.1    | Live Loads for Structural Members .....   | 12 |
| Table 5.2    | Values of $K_A$ , Soil Unit Weight, and Equivalent fluid Density by Soil Type.....                  | 15 |
| Table 5.6    | Minimum Frost Depths for Residential Footings.....  | 16 |
| Table 6.4    | Basic Wind Velocity Pressures (psf) for Suburban Exposure.....                                      | 18 |
| Table 6.5    | Lateral Pressure Coefficients for Application to Vertical Projected Area of Roof and Wall .....     | 19 |
| Table 6.6    | Pressure Coefficients for Building Components, Cladding, and Various Assemblies .....               | 20 |
| Table 6.9.1  | Windborne Debris Protection Fastening Schedule for Wood Structural Panels...                        | 22 |
| Table 6.9.2a | Missile Types .....   | 22 |
| Table 6.9.2b | Wind-Borne Debris Missile Impact Criteria for Missile Types Defined in Table 6.9.2a.....            | 22 |
| Table 8.3a   | Site Amplification Factor ( $F_a$ ) for Typical Firm Soils .....                                    | 24 |
| Table 8.3b   | Seismic Response Modifiers - R .....  | 24 |

# List of Figures

|            |   |    |
|------------|---|----|
| Figure 4.4 | Application of Live Load Reductions .....                           | 14 |
| Figure 5.3 | Triangular Pressure Distribution on a Basement Foundation Wall..... | 15 |
| Figure 6.3 | Wind Exposure Illustrations.....                                    | 18 |
| Figure 6.5 | Wind Loads for Design of Main Wind-Force Resisting System .....     | 19 |



## 1. GENERAL

### 1.1 SCOPE

This guide provides minimum structural loads and related guidance for the design and analysis of residential buildings limited to one- and two-family attached (townhouses) and detached dwellings of three stories or less above the foundation with a maximum height of 40 feet as measured from the roof peak to the lowest adjacent finish grade. Loading conditions that are to be avoided, such as those produced by expansive soils and frost heave, are also addressed. Conditions not addressed in the scope of this guide shall be evaluated in accordance with ASCE 7-98<sup>1</sup>, the local building code, or accepted engineering practice. This guide is not intended to preclude the use of sound engineering judgment or alternate methods of design.

*Note: This document has been written using mandatory terms, such as "shall," to align with current building code style. However, this guide is not a regulatory document, neither has its development followed accepted rules of consensus.*

*1.1 Commentary: The development of this guide has sought to compile design load information that is particularly relevant to the scope of residential buildings addressed. As mentioned in the Preface, this guide draws relevant technical information from several resources including existing and past research, standards, local and national building codes, and similar international documents. The maximum height limit, while somewhat arbitrary, defines a clear limit to the application of this guide.*

### 1.2 PURPOSE

This guide is intended to provide a technically sound, concise, and practical method of determining design loads for engineering analysis of residential buildings as described in Section 1.1-Scope.

*1.2 Commentary: To the extent possible, a goal to facilitate efficient engineering analysis and design of residential structures while maintaining a practical balance between simplicity and accuracy has been followed throughout this document.*

### 1.3 DEFINITIONS

**Air-Freezing Index:** A climate index, in units of °F-days, used to determine ground freezing potential and, specifically, frost depth for foundation design.

*1.3 Commentary:*

*Refer to Figure A-1 of Appendix A.*

**Allowable Stress:** A material stress value derived by dividing a characteristic strength property by a safety factor.

**Allowable Stress Design (ASD):** A method of design whereby structural members are proportioned such that the maximum computed stresses due the application of design loads do not exceed a specified allowable stress value.

---

<sup>1</sup>Minimum Design Loads for Buildings and Other Structures, ASCE Standard 7 (ASCE 7-98), American Society of Civil Engineers, Reston, VA, 1999.

**Basic Wind Speed (V):** A design wind speed based on a gust wind speed at 33 feet (10 meters) above ground in open, flat terrain. *Refer to Figure A-2 of Appendix A.*

**Building:** A residential structure that contains either a single-family dwelling unit or multiple attached dwelling units (i.e., townhouse construction), neither which exceed three stories in height above the foundation or a maximum height of 40 feet as measured from the roof peak to the lowest adjacent finish grade.

**Concentrated Load:** A load that is applied to a small surface area (i.e., point load).

**Component:** A part, element, or member, and not necessarily the whole of a structural system. *While not considered as part of the structural system, cladding is a component that experiences structural loading (i.e., service load).*

**Dead Load:** The estimated permanent building material loads from roof, floor, wall, and foundation systems, and also from claddings, finishes, and fixed equipment. *Refer to Section 3.*

**Diaphragm:** A framing system that derives its strength from the presence of structural sheathing securely attached to the framing; used to resist building lateral (shear) loads in light-frame construction. *Floor and roof diaphragms are known as "horizontal diaphragms" and shear walls are sometimes called "vertical diaphragms".*

**Dwelling Unit:** A dwelling unit is a structure suitable for housing a single family. Attached garages, appurtenances, and other accessory structures are considered to be a part of the dwelling unit.

**Earthquake Load:** The equivalent static load as a result of a building's inertial response to a design earthquake ground motion. *Refer to Section 8.*

**Earthquake Spectral Response Acceleration:** A measure of the magnitude of design earthquake ground motion (as a percent of gravity) for determination of earthquake load. *Refer to Figure A-4 of Appendix A.*

**Flood Hazard Area:** An area subject to standing or moving water during a design flood, includes coastal and riverine flooding. *Refer to Section 5.4.*

**Ground Snow Load:** Loads from snow deposited and accumulated on the ground used to determine snow loads on roofs. *Refer to Figure A-3 of Appendix A.*

**Horizontal Diaphragm:** A sheathed roof, floor, or other membrane system acting to horizontally transfer and distribute lateral forces experienced by the building to vertical shear resisting systems.

**Lateral Force Resisting System (LFRS):** An assemblage of structural elements or systems (i.e., floor and roof diaphragms and shear walls) designed to provide lateral resistance to wind and seismic forces experienced by a building.

*The LFRS also provides support for components and cladding that transfer lateral loads to the LFRS.*

**Lateral Load:** Lateral loads are transverse loads on a building or building surface that produce racking (shear) forces in the LFRS or out-of-plane bending loads on individual walls and components.

*Lateral loads are most commonly produced by horizontal wind or seismic forces. For lateral loads from coastal or riverine flood zones, refer to ASCE 7-98.*

**Live Load:** Sustained and time-varying (transient) loads produced by human occupants, furnishings, non-fixed equipment, storage, and construction and maintenance activities.

*Refer to Section 4.*

**Load and Resistance Factor Design (LRFD):** A design method whereby structural members are proportioned such that the computed material stresses due to factored nominal loads do not exceed factored resistance (stress) values.

*The LRFD method is also known as Strength Design.*

**Load:** A force or pressure acting on a building component or system that originates from the weight of building materials (dead load), occupants and contents (live loads), and environmental effects (i.e., soil, wind, snow, or earthquake loads).

*While not addressed, loads may also be generated by differential movement of parts of the building and by restrained dimensional changes; refer to ASCE 7-98 for additional guidance.*

**Load Path:** The "pathway" by which loads are transferred through structural members and connections such that the building and its component parts maintain stability under design loads.

*An example of a load path includes the inter-connection of the roof, walls, and foundation to resist wind uplift forces. Load paths often include actions from a combination of gravity, uplift, and overturning forces.*

**Main Wind Force Resisting System (MWFRS):** An assemblage of structural elements that receive and resist wind load (pressure) from multiple components or surfaces of a building or that comprise a large tributary surface area of the building.

*The MWFRS may include roof trusses, diaphragms, and portions of the uplift or overturning load path.*

**Seismic Site Coefficient:** A factor used to amplify or dampen earthquake ground motions based on soil conditions underlying the site and the magnitude of the design ground motion.

*For example, "weak" or "soft" soils tend to amplify weak earthquake ground motions but dampen strong earthquake ground motions.*

**Shear Wall:** A wall with racking (in-plane shear) strength that is capable of resisting design lateral building loads and is also known as a braced wall.

**Snow Load:** The load on a roof of a building from uniform and drifting (unbalanced) snow deposition and accumulation.

*Refer to Section 7.*

**Soil Lateral Load:** Horizontal loads due to lateral pressure from soil and water in soil.

*Refer to Section 5.*

**Story:** A level of a building generally intended for human occupancy with the story height measured between floor and ceiling surfaces.

**Strength Design:** See Load and Resistance Factor Design.

**Structural Safety:** The ability of the building and its structural components to adequately withstand design loading conditions and associated load effects with an acceptably low probability of structural failure.

**Structural Serviceability:** The ability of the building and its components to provide reasonable service to the occupants or owner regarding functional performance expectations of the structure, usually under normal conditions of use.

**Structural System:** An assemblage of structural elements or components that may include built-up members, walls, floors, roofs, fastenings, or even a whole building.

**Tributary Area:** Surface area supported by a structural member based on geometry (i.e., the spacing and span of members) rather than stiffness.

**Wind-Borne Debris:** Man-made or natural materials that become air-borne missiles during extreme wind speeds.

*For example, roof shingles are a typical source of debris in residential settings during hurricanes.*

**Wind Load:** The wind pressure and forces exerted on a building and its components as a result of the basic wind speed with adjustment for exposure and other factors.

*Refer to Section 6.*

**1.4 SYMBOLS AND UNITS**

The symbols listed and defined in this section, as well as Customary English units, are used throughout this guide. Factors for conversion from English to Metric units are provided in Appendix C.

*1.4 Commentary: The units associated with the symbols are defined by the context of use in this guide (certain symbols may assume different representations of units depending on the particular use). The user is cautioned to verify the correct use or conversion of units in the execution of calculations.*

- A<sub>T</sub> - Tributary floor, roof, or wall surface area
- C<sub>e</sub> - Roof snow load exposure factor
- C<sub>s</sub> - Roof slope factor
- D - Dead load
- E - Earthquake (seismic) load
- F<sub>a</sub> - Seismic site coefficient
- h - Depth of soil backfill
- H - Soil lateral load
- K<sub>a</sub> - Active soil pressure coefficient
- K<sub>D</sub> - Wind directionality factor
- K<sub>z</sub> - Velocity pressure exposure coefficient
- L<sub>o</sub> - Unreduced floor live load
- L<sub>r</sub> - Uniform roof live load
- L - Live load
- p - Uniform roof snow load
- p<sub>g</sub> - Uniform ground snow load
- P - Lateral soil pressure at depth *h*
- q - Soil equivalent fluid density
- R - Seismic response modification factor
- S - Snow load
- S<sub>DS</sub> - Seismic design spectral response acceleration.
- S<sub>s</sub> - Mapped spectral response acceleration at short periods (0.2 seconds).
- V - Basic Wind Speed
- W - Wind load\*
- W<sub>u</sub> - Wind uplift on roof or suction load\*
- W<sub>s</sub> - Weight of building (dead load) used in seismic load analysis
- w - Soil unit weight

\*Wind loads include internal and external surface pressure.

## 1.5 BASIC DESIGN CRITERIA

**1.5.1 Structural Safety and Integrity.** Buildings, and all parts thereof, shall safely resist the structural actions and load effects resulting from the load combinations specified in this guide using the design data of Appendix A. Structural components, systems, and connections shall be designed such that a continuous load path is present and capable of transmitting lateral and vertical design loads through the structure and ultimately to the ground. Buildings shall be designed such that the local failure of any one component or element of the structural system will not precipitate immediate and catastrophic damage to the remaining structure.

*1.5.1 Commentary: The basic criteria for structural safety and integrity are inherent to the fundamental objectives of structural design. Safety requires that the stresses induced by design loads do not exceed the ability of structural members and connections to resist the induced stresses with a reasonable margin of safety. In general, safety implies a low probability of failure. While concepts of safety can be placed in analytical form and incorporated into various design formats (i.e., ASD or LRFD), the establishment of an acceptable level of safety as a “target” for design is a subjective matter that relies heavily on interpretations of past successful or unsuccessful design and construction practices. Structural safety in terms of residential design is largely an unexplored realm of engineering science and specification development.*

*Structural integrity is a broader area of concern than safety and is related to the execution of design practices that ensure that intended levels of safety are achieved and that the consequences of extreme loads (beyond that intended by design) are reasonably minimized. Thus, the “common sense” concept of providing a continuous load path with the intended level of safety is paramount to achieving overall structural integrity. It implies an idealistic goal of balanced design where no “weak links” exist in the structural system. It is also similar to the basic principle of providing for equilibrium of forces. Structural integrity also implies that a failure should not propagate to damage beyond that which would be in proportion to the nature of the cause. This design concept is known as redundancy. Typical*



*light-frame homes are generally considered to be highly redundant structures and special evaluation of redundancy is not usual.*

**1.5.2 Structural Serviceability.** Structural components and systems shall provide adequate stiffness to limit deflections, lateral drift, deformations, and vibrations that may otherwise exceed normal expectations relative to the intended use, occupancy, and function of the building. Alternatively, owner-specified or project-specific serviceability criteria may be substituted for “normal expectations.”

*1.5.2 Commentary: Structural serviceability is a criteria of secondary importance to safety and can be ideally considered as a completely independent objective of design. Nevertheless, it is a necessary design consideration. Structural serviceability is generally aimed at providing for acceptable function of the building system and components under normal use conditions or “service loads.”*

*Design loads specified for the purpose of safety are not necessarily appropriate for provision of serviceability. However, as a matter of convenience, serviceability limits (i.e., deflection limits) are typically evaluated using the same design loads used for safety purposes. In such cases, the evaluation is “calibrated” to provide reasonable function under a service load condition.*

**1.5.3 Durability.** The basic design criteria are based on the assumption that the specified materials, building design, installation, and maintenance will result in adequate structural safety and serviceability over the intended life of the building.

*1.5.3 Commentary: Durability is an important design criteria and can be considered as a time-dependent aspect of structural safety and integrity. The provision of durability is directly related to the life-expectancy of a structure, its first cost, and its operational or maintenance costs. Durability cannot be easily analyzed, tested, or predicted and is very dependent on material selection, architectural detailing (i.e., protective overhangs, flashing, etc.), and site specific climatic or ground conditions (i.e., salt spray from ocean exposure, soil sulfate content, etc.). A structural designer should consider these effects on the long-term structural integrity of a building. Certain practices or criteria related to durability are*

*mandated in most building codes, usually by virtue of reaction to past experience.*

**1.5.4 Structural Evaluation Methods.** Structural evaluations shall use methods of analysis as described in Section 1.5.4.1, testing in accordance with Section 1.5.4.2, conventional construction practice in accordance with Section 1.5.4.3, or a combination of these approaches.

**1.5.4.1 Analysis.** The structural resistance of systems and elements of buildings shall be evaluated using reasonable methods of analysis including, but not limited to, those methods included in Appendix B or as required by the local building code. The design analysis shall apply design loads and load combinations determined in accordance with Section 2 of this guide or the local building code.

*1.5.4.1 Commentary: The design references in Appendix B are provided as a matter of convenience and should not be considered exhaustive of available or acceptable methods of design.*

**1.5.4.2 Testing.** For the purpose of structural evaluation or design verification, the structural resistance of elements or assemblies shall be evaluated by testing in accordance with recognized test methods. Test specimens and loading conditions shall be comparable to that experienced in the actual end-use. A sufficient number of tests covering an expected range of materials and assembly characteristics shall be conducted to adequately document the variability and range of structural properties commensurate with the intended scope of application of the test data. Allowable design values for Allowable Stress Design (ASD) shall be established on the basis of the test data and incorporate a safety factor reduction in reasonable agreement with recognized material design specifications, standards, and accepted design practice. Design values and resistance factors for Load and Resistance Factor Design (LRFD) or Strength Design shall be established on the basis of the test data in reasonable agreement with recognized material design specifications and standards.

*1.5.4.2 Commentary: In general, recognized material design specifications (Appendix B) embody a standardized treatment of relevant material test data in the development of design procedures that accompany the analysis of individual structural elements using simplified models (i.e., simply-supported beam or column elements). In this context, these specifications and standards establish material design values that incorporate safety factors (ASD), resistance factors (LRFD), and other necessary material property adjustments. However, design information related to the consideration of structural assemblies or systems is often lacking or may not be representative of specific end-use conditions and the actual structural capacity (strength) and stiffness of the particular system being designed. While this section provides only general guidance, it is intended to bring recognition to the traditional practice of "proof testing" as a method of design verification, particularly when current practices, specifications, standards, or manufacturer data may not provide an efficient,*

*accurate, or complete basis of design.*

**1.5.4.3 Conventional Construction Practice.** Prescriptive construction provisions for residential construction shall be considered to be an acceptable method of design in accordance with the local building code. Where the scope limitations of such provisions are exceeded, the entire building or certain affected portions shall be evaluated in accordance with Sections 1.5.4.1 or 1.5.4.2.

*1.5.4.3 Commentary: The use of code-approved prescriptive (pre-designed or deemed-to-comply) construction solutions is a routine occurrence in residential building design. The designer must, however, verify that the conditions of use do not exceed applicable scope limitations.*

## 2. LOAD COMBINATIONS

### 2.1 GENERAL

Design load combinations shall comply with Table 2.1 for use with design methods that are based upon Allowable Stress Design (ASD) or Load and Resistance Factor (Strength) Design (LRFD). The individual loads used in the load combinations of Table 2.1 shall be determined in accordance with Sections 3.0 through 8.0. Load combinations typically used for design of residential buildings are provided in Table 2.2.

**TABLE 2.1  
GENERALIZED LOAD COMBINATIONS<sup>1</sup>**

| ASD LOAD COMBINATIONS                | LRFD LOAD COMBINATIONS                             |
|--------------------------------------|--|
| D + H + L + 0.3(L <sub>r</sub> or S) | 1.2D + 1.6(L+H) + 0.5(L <sub>r</sub> or S)         |
| D + H + (L <sub>r</sub> or S) + 0.3L | 1.2D + 1.6(L <sub>r</sub> or S) + 0.5 (L or 0.8 W) |
| D + (W or 0.7E) + 0.5L + 0.2S        | 1.2D + 1.6W + 0.5L + 0.5(L <sub>r</sub> or S)      |
| 0.6D + W                             | 1.2D + 1.0E + 0.5L + 0.2S                          |
| 0.6D + 0.7E                          | 0.9D + 1.6W  |
|                                      | 0.9D + 1.0E  |

Note:

<sup>1</sup>For load conditions not addressed in this guide (e.g., flood loads, rain loads, etc.), refer to ASCE 7-98.

**TABLE 2.2  
LOAD COMBINATIONS TYPICALLY USED FOR THE DESIGN OF  
RESIDENTIAL BUILDING COMPONENTS AND SYSTEMS**

| COMPONENT OR SYSTEM  | ASD LOAD COMBINATIONS   | LRFD LOAD COMBINATIONS  |
|--|---|---|
| Foundation Wall<br>(Gravity & Soil Lateral Loads)  | D + H<br>D + H + L + 0.3(L <sub>r</sub> or S)<br>D + H + (L <sub>r</sub> or S) + 0.3L | 1.2D + 1.6H<br>1.2D + 1.6H + 1.6L + 0.5(L <sub>r</sub> or S)<br>1.2D + 1.6H + 1.6(L <sub>r</sub> or S) + 0.5L |
| Headers, Girders, Floor System, Interior Load Bearing Walls, Footings<br>(Gravity Loads) | D + L + 0.3 (L <sub>r</sub> or S)<br>D + (L <sub>r</sub> or S) + 0.3 L                | 1.2D + 1.6L + 0.5 (L <sub>r</sub> or S)<br>1.2D + 1.6(L <sub>r</sub> or S) + 0.5 L                            |
| Exterior Load Bearing Walls<br>(Gravity & Wind Lateral Load)                             | Same as above plus,<br>D + W<br>D + 0.7E + 0.5L + 0.2S                                | Same as above plus,<br>1.2D + 1.6W<br>1.2D + 1.0E + 0.5L + 0.2S   |
| Roof Rafters, Trusses, & Beams;<br>Roof & Wall Sheathing<br>(Gravity & Transverse Loads) | D + (L <sub>r</sub> or S)<br>0.6D + W <sub>u</sub><br>D + W                           | 1.2D + 1.6(L <sub>r</sub> or S)<br>0.9D + 1.6W <sub>u</sub><br>1.2D + 1.6W                                    |
| Floor Diaphragms and<br>Shear Walls<br>(Lateral & Overturning Loads)                     | 0.6D + W<br>0.6D + 0.7E   | 0.9D + 1.6W<br>0.9D + 1.0E  |

*2.1 Commentary: The load combinations of this section and Table 2.1 are intended to be applied uniformly for residential building design using material design specifications listed in Appendix B including, but not limited to, wood, concrete, steel, and masonry design specifications. Combined load proportioning of ASD load combinations has been done in a manner consistent with the proportioning of loads in the LRFD format. This proportioning will result in a more realistic application of ASD load combinations than may be found in existing codes and design specifications using the ASD format. Thus, the computed loads for certain ASD load combinations will be comparatively less. The 1.6 wind load factor is relatively new and, in part, it is based on the use of gust wind speeds (see Figure A-2 of Appendix A) rather than fastest-mile wind speed values as found in older design wind maps in the United States.*

**2.2 LOAD REDUCTIONS**

Load reductions to account for multiple transient loads shall not be permitted for use with the load combinations of Table 2.1, except as permitted for live loads in Section 4.

*2.2 Commentary: Because adequate proportioning of multiple transient loads has been included in the ASD and LRFD load combinations of Tables 2.1 and 2.2, the practice of applying an additional reduction for multiple transient loads (i.e., use of a 0.75 load reduction factor) is disallowed in this guide.*

**2.3 INCREASE IN ALLOWABLE STRESS**

Increase in allowable material stress values for wind and seismic load conditions shall not be permitted for use with the load combinations of Table 2.1 except when justified by the specific material or structural system’s time-dependent response to the load.

*2.3 Commentary: The use of a one-third allowable stress increase for wind and seismic loading is not permitted in this guide because adequate proportioning of ASD load combinations in Tables 2.1 and 2.2 has accounted for this past practice.*

**3. DEAD LOAD (D)**

Dead loads shall be based on the actual materials used in the construction or the estimated weights and densities of commonly used materials and building constructions as shown in Tables 3.0a and b.

*3. Commentary: Dead load values for various construction materials are provided as a matter of convenience to the designer. These values are based on typical practice as defined in various sources such as the Residential Structural Design Guide and ASCE 7-98. The designer should use dead load values representative of the actual construction.*

**TABLE 3.0a  
TYPICAL DEAD LOADS FOR COMMON  
RESIDENTIAL CONSTRUCTIONS**

|  |                              |                     |          |
|--|------------------------------|---------------------|----------|
| <b>Roof Construction</b>   |                              |                     |          |
| Light wood or steel framing (trusses), sheathing & gypsum board ceiling, with:     |                              |                     |          |
| - asphalt shingles, metal roofing, or wood shakes or shingles                      |                              |                     | 15 psf   |
| - built-up roll roofing, tar and gravel  |                              |                     | 18 psf   |
| - light weight tile or 1/4” slate  |                              |                     | 20 psf   |
| - conventional clay tile, concrete tile, or 3/8” slate                             |                              |                     | 25 psf   |
| <b>Floor Construction</b>  |                              |                     |          |
| Light wood or steel framing, wood sheathing & gypsum board ceiling, with:          |                              |                     |          |
| - carpet or vinyl flooring   |                              |                     | 10 psf   |
| - wood flooring  |                              |                     | 12 psf   |
| - ceramic tile & thin-set or dry-set mortar  |                              |                     | 15 psf   |
| - 1/2”slate or ceramic tile with 1/2” mortar bed                                   |                              |                     | 20 psf   |
| <b>Light-Frame Wall Construction</b>   |                              |                     |          |
| Light wood or steel framing, wood sheathing, & gypsum board interior finish, with: |                              |                     |          |
| - vinyl or aluminum siding   |                              |                     | 8 psf    |
| - lap wood siding  |                              |                     | 9 psf    |
| - thin coat stucco on insulation board   |                              |                     | 11 psf   |
| - 7/8” portland cement stucco  |                              |                     | 17 psf   |
| - standard brick veneer  |                              |                     | 45 psf   |
| Interior partitions (2x4 at 16” o.c. with 1/2” gypsum board applied to both sides) |                              |                     |          |
| 6 psf  |                              |                     |          |
| <b>Concrete or Masonry Wall Construction</b>                                       | Masonry (light-weight block) |                     | Concrete |
|  | Hollow                       | Solid or Full Grout |          |
| 4” thick wall  | 22 psf                       | --                  | 48 psf   |
| 6” thick wall  | 24 psf                       | 55 psf              | 72 psf   |
| 8” thick wall  | 31 psf                       | 75 psf              | 96 psf   |
| 10” thick wall   | 37 psf                       | 95 psf              | 120 psf  |
| 12” thick wall   | 43 psf                       | 115 psf             | 144 psf  |

**TABLE 3.0b  
DENSITIES FOR COMMON  
RESIDENTIAL CONSTRUCTION MATERIALS**

|                                       |               |                                  |         |
|---------------------------------------|---------------|----------------------------------|---------|
| Aluminum                              | 170 pcf       | Wood Structural Panels           |         |
| Copper                                | 556 pcf       | - Plywood                        | 36 pcf  |
| Steel                                 | 492 pcf       | - Oriented Strand Board          | 40 pcf  |
| Concrete (normal wt. w/reinforcement) | 144 pcf       | Gypsum Board                     | 50 pcf  |
| Masonry, Grout                        | 140 pcf       | Stone (Quarried and Piled)       |         |
| Masonry, Brick                        | 100 – 130 pcf | - Shale                          | 92 pcf  |
| Masonry, Concrete                     | 105 – 135 pcf | - Granite and Slate              | 96 pcf  |
|                                       |               | - Sandstone                      | 82 pcf  |
| Glass                                 | 160 pcf       | Earth                            |         |
| Wood (approx. 10% moisture content)*  |               | - Sand and gravel, dry,<br>loose | 100 pcf |
| - Spruce-Pine-Fir (G=0.42)            | 29 pcf        | - Sand and gravel, wet           | 120 pcf |
| - Spruce-Pine-Fir, South (G=0.36)     | 25 pcf        | - Clay, damp                     | 110 pcf |
| - Southern Yellow Pine (G=0.55)       | 37 pcf        | - Silt, mist, loose              | 78 pcf  |
| - Douglas Fir – Larch (G=0.5)         | 34 pcf        | - Silt, moist, packed            | 96 pcf  |
| - Hem-Fir (G=0.43)                    | 28 pcf        |                                  |         |
| - Mixed Oak (G=0.68)                  | 47 pcf        | Slate                            | 172 pcf |
| Water                                 | 62.4 pcf      | Granite                          | 153 pcf |
|                                       |               | Marble                           | 156 pcf |
|                                       |               | Sandstone                        | 137 pcf |

\*G-Specific Gravity

## 4. LIVE LOAD (L)

### 4.1 GENERAL

Live loads shall be based on the values provided in Table 4.1.

**TABLE 4.1  
LIVE LOADS FOR STRUCTURAL MEMBERS**

| APPLICATION                    | UNIFORM LOAD (psf or plf) | CONCENTRATED LOAD (lbs) |
|--------------------------------|---------------------------|-------------------------|
| Roof                           |                           |                         |
| - Slope $\geq$ 4:12            | 15 psf                    | 250 lbs                 |
| - Slope $<$ 4:12               | 20 psf                    | 250 lbs                 |
| Attics                         |                           |                         |
| - without storage <sup>1</sup> | 10 psf                    | 250 lbs                 |
| - with storage <sup>2</sup>    | 20 psf                    | 250 lbs                 |
| Floors                         |                           |                         |
| - Bedroom areas                | 30 psf                    | 300 lbs                 |
| - Other areas                  | 40 psf                    | 300 lbs                 |
| Garages                        | 40 psf                    | 2,000 lbs               |
| Decks & Balconies <sup>3</sup> | 60 psf                    | 300 lbs                 |
| Stairs                         | 40 psf                    | 300 lbs                 |
| Guardrails & Handrails         | 20 plf                    | 200 lbs                 |
| Grab bars                      | n/a                       | 250 lbs                 |

Notes:

<sup>1</sup>Attics “without storage” are considered to be attic spaces without adequate access or open spaces that would be necessary to allow for its significant use as a storage area. The 10 psf minimum load for attics without storage is intended solely for the design of attic members (i.e., ceiling joist) to allow for safe function during construction, maintenance, and related activities.

<sup>2</sup>Applies to portions of attic areas that are considered to be accessible for storage.

<sup>3</sup>For decks and balconies that are not more than 48 inches above finish grade, the deck load shall be permitted to be based on the interior floor area served by the deck (i.e., 40 psf).

*4.1 Commentary: The live loads of Table 4.1 represent typical practice, but may vary relative to local building code requirements. In particular, the values for decks and balconies provides an allowance for use of a 40 psf load for decks and balconies not greater than 48 inches above finish grade (i.e., a minimal hazard in the event of collapse). Most deck and balcony failures have been the result of inadequate detailing and design of connections to the house structure rather than an inadequacy in the assignment of live loads.*

## 4.2 CONCENTRATED LOADS

Concentrated loads shall be applied to a small surface area consistent with the application and shall be located and directed to produce the maximum possible load effect on the element or assembly under consideration. Concentrated live loads shall not be required to be applied simultaneously with uniform live loads.

## 4.3 MINIMUM ATTIC LOAD

The live load for attics with storage shall be permitted to be reduced in accordance with Section 4.4.2 when considered in combination with other sources of live loads as required in the load combinations of Section 2. The live load for attics without storage shall not be included in the load combinations of Section 2, except for the purpose of designing attic floor members. Attics intended for occupancy shall be designed using live loads as required for floors.

*4.3 Commentary: Attic live loads are not usually included when considering the combined effects of other roof and floor live loads. In keeping with reasonable proportioning of loads, this guide requires live loads for attics with storage to be considered in determining the live load component of the load combinations in Section 2.*

## 4.4 LIVE LOAD REDUCTION

**4.4.1 Tributary Floor Area.** A structural member which supports a tributary floor area of greater than 200 ft<sup>2</sup> on a given story is permitted to be designed using a reduced uniform floor live load for each qualifying story in accordance with the following formula:

$$L = L_o \left( 0.25 + \frac{10.6}{\sqrt{A_T}} \right) \geq 0.75 \quad \text{for } A_T > 200 \text{ ft}^2$$

$A_T$  is the tributary area of floor surface in square feet supported by the structural member and  $L_o$  is the floor live load from Table 4.0.

*4.4 Commentary: The uniform live load values for floors in Table 4.1 are based on a floor area of 200 square feet. As the floor area under consideration becomes larger than 200 square feet, the potential for a large uniform live load over the entire area decreases. The equation for live load reduction makes this adjustment specifically for residential occupancies. The equation used in existing building codes and standards is based on commercial buildings.*

**4.4.2 Multiple Stories.** When floor, roof, and attic live loads from multiple story levels are considered in combination, the total live load for use in the load combinations of Section 2 shall be factored as follows:

$$L = L_1 + 0.7(L_2 + L_3 + \dots)$$

where  $L_1$  is the live load from Table 4.1 producing the maximum individual load effect and  $L_2$ ,  $L_3$ , and so forth are live loads from other sources or stories in accordance with Table 4.1. The live load reductions shall be applied as shown in Figure 4.4.

*The approach of combining multiple sources of live loads (multi-story construction) provides a conservative adjustment, not on the basis of floor area supported, but rather on the basis of the statistical "independence" and the improbability of maximum live loads occurring on different stories of the dwelling at the same time. This live load adjustment for multiple stories is not recognized in existing building codes and design standards.*

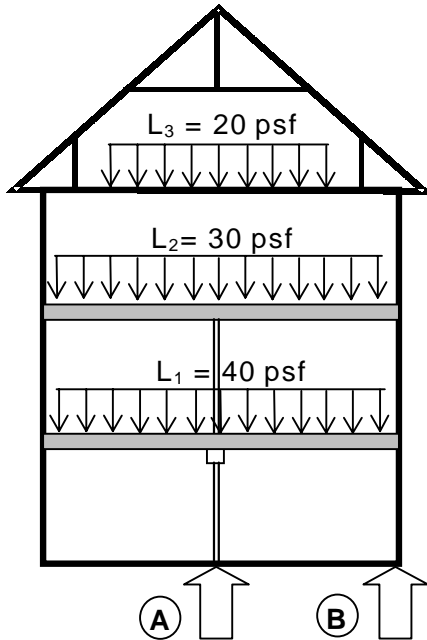

Live Load @ A =  $L_1 + 0.7(L_2)$   
 Live Load @ B =  $L_1 + 0.7(L_2 + L_3)$

Notes:

1.  $L_1$ ,  $L_2$ , and  $L_3$  may be reduced according to their individual floor tributary areas when  $A_T$  for each is greater than  $200 \text{ ft}^2$ ; refer to Section 4.4.1.
2. Load values shown for  $L_1$ ,  $L_2$ , and  $L_3$  are for example only.

**FIGURE 4.4**  
**APPLICATION OF LIVE LOAD REDUCTIONS**

#### 4.5 UNUSUAL LIVE LOADS

Residential buildings with areas subject to special use or equipment loads or other unusual live loads not addressed in Table 4.1 shall be designed using an appropriate live load value for the affected portions of the structure.

*4.5 Commentary: Special use conditions include rooms that are used for activities that are not typical to residential construction and that are not addressed in the values of Table 4.1. Examples include rooms intended for heavy storage, office space, libraries, etc. Special equipment loads may include items such as hot tubs, water beds, exercise equipment, etc.*

### 5. SOIL LATERAL LOAD (H)

#### 5.1 GENERAL

Soil lateral loads for foundation and retaining wall design shall be determined in accordance with this section.

#### 5.2 EQUIVALENT FLUID DENSITY

The values of  $K_a$  in Table 5.2 shall be used to determine the equivalent fluid density value for well-drained, lightly compacted soils in accordance with the following equation:

$$q = K_a w$$

*5.2 Commentary: The equivalent fluid density (Rankine) method of determining soil lateral loads is a traditional method that is relatively simple and effective for shallow residential foundation walls and soil retaining structures. For typical residential foundation wall design, the*



For saturated soil conditions as would be experienced in a flood plain or in poorly drained soil, an equivalent fluid density value of 85 pcf shall be used.

*use of a minimum 30 pcf equivalent fluid density has been in long-term use with reasonable success.*

**TABLE 5.2  
VALUES OF  $K_A$ , SOIL UNIT WEIGHT,  
AND EQUIVALENT FLUID DENSITY BY SOIL TYPE<sup>1,2</sup>**

| Type of Soil <sup>3</sup><br>(unified soil classification) | Active Pressure Coefficient ( $K_a$ ) | Soil Unit Weight (pcf) | Equivalent Fluid Density (pcf) |
|--|---------------------------------------|------------------------|--------------------------------|
| Sand or gravel<br>(GW, GP, GM, SW, SP)                     | 0.26                                  | 115                    | 30                             |
| Silty sand, silt, and sandy silt<br>(GC, SM)               | 0.35                                  | 100                    | 35                             |
| Clay-silt, silty clay<br>(SM-SC, SC, ML, ML-CL)            | 0.45                                  | 100                    | 45                             |
| Clay<br>(CL, MH, CH)                                       | 0.6                                   | 100                    | 60                             |

Notes:

<sup>1</sup>The table values are applicable to well-drained foundations with less than 10 feet of backfill placed with light compaction as is common in residential construction.

<sup>2</sup>The table values do not consider the significantly higher loads that can result from expansive clays and the lateral expansion of moist, frozen soil. Such conditions should be avoided by eliminating expansive clays or frost-susceptible soil (i.e., silty soil) adjacent to the foundation wall and providing for adequate surface and foundation drainage.

<sup>3</sup>Organic silts and clays and expansive clays are unsuitable for backfill material and design values for these soil types are not provided.

**5.3 LATERAL SOIL PRESSURE**

The lateral soil pressure,  $P$ , at depth,  $h$ , shall be determined using a triangular uniform load (increasing with depth) in accordance with Figure 5.3 and the following formula:

$$P = qh \text{ (psf)}$$

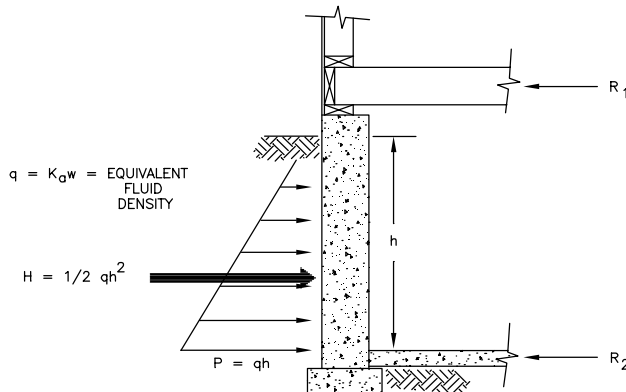

**FIGURE 5.3  
TRIANGULAR PRESSURE DISTRIBUTION ON A BASEMENT  
FOUNDATION WALL**

*5.3 Commentary: This section provides for calculation based on the traditional (Rankine) assumption of a triangular load distribution. Actual pressure distribution can vary from this assumption and, therefore, alternative methods of calculation using different soil pressure distribution models are permissible. However, the use of a simple triangular distribution has generally provided serviceable designs for shallow foundations and soil retaining structures.*

**5.4 FLOOD LOADS**

In areas subject to hydrodynamic loads due to moving flood water or hydrostatic loads due to standing flood water, the provisions of ASCE 7-98, accepted engineering practice, or local requirements for design of building foundations in flood hazard areas shall be followed.

*5.4 Commentary: In general, elevated foundations (e.g., pile foundations in coastal flood zones) should be used to minimize or avoid hydrodynamic flood loads from velocity flow (fast moving flood waters). Ideally, locating homes in flood plains (usually defined by a 100-yr flood elevation) should be avoided. Local flood plain ordinances, many of which are based upon the National Flood Insurance Program (NFIP) regulations, should be consulted.*

**5.5 EXPANSIVE SOILS**

Foundation on expansive clay soils shall be designed such that forces from expansion and contraction are avoided or the foundation shall be designed to resist forces from differential soil movement in accordance with accepted engineering practice.

*5.5 Commentary: Expansive soil forces require special design considerations to prevent damage to foundations depending on the degree to which a clay soil exhibits expansive behavior. Refer to references in Appendix B.*

**5.6 FROST PROTECTION**

Foundations shall be adequately protected against frost heave or bear on soils at a depth equal to or exceeding that required by Table 5.6 using the Air-Freezing Index (AFI) map, Figure A-1, in Appendix A.

*5.6 Commentary: In general, residential foundations have been protected against frost by placing footings at a depth equivalent to a locally prescribed frost depth. Frost depths in accordance with Table 5.6, while technically accurate, may not agree with locally prescribed frost depths which rely on various interpretations of local experience. Alternate means of frost protection, by use of insulated foundations or non-frost susceptible soil, may be used (refer to Appendix B for design guidance).*

**TABLE 5.6  
MINIMUM FROST DEPTHS FOR RESIDENTIAL FOOTINGS**

| <b>Air-Freezing Index (°F-days)</b> | <b>Footing Depth (inches)</b> |
|-------------------------------------|-------------------------------|
| 250 or less                         | 12                            |
| 500                                 | 18                            |
| 1,000                               | 24                            |
| 2,000                               | 36                            |
| 3,000                               | 48                            |
| 4,000                               | 60                            |

- Notes:
1. Interpolation is permissible.
  2. The values do not apply to mountainous terrain or to Alaska.

## 6. WIND LOAD (W)

### 6.1 GENERAL

Wind loads shall be determined in accordance with this section.

### 6.2 BASIC WIND SPEED

For the purpose of calculating wind loads, a site's basic wind speed shall be based on the gust wind speed provided in Figure A-2 of Appendix A.

*6.2 Commentary: The basic wind speed in this guide is based on a gust measurement rather than a sustained (1-min average) or fastest-mile measurement. Most older U.S. wind maps use the fastest-mile measurement of wind speed. If an older fastest-mile wind map is used with this guide, the wind speed must be converted to a gust measurement as shown below.*

| Gust, mph | Fastest-mile, mph |
|-----------|-------------------|
| 90        | 75                |
| 100       | 80                |
| 110       | 90                |
| 120       | 100               |
| 130       | 110               |
| 140       | 120               |
| 150       | 130               |

### 6.3 WIND EXPOSURE

Wind exposure for a specific building site shall be designated as one of the following categories as illustrated in Figure 6.3:

*Open* - Exposed open terrain with few, well scattered obstructions having heights generally less than 30 feet; it includes flat open country, grasslands, and direct coastal exposures.

*Suburban* - Urban, suburban, and mixed wooded areas, or other terrain with many obstructions having the size of single-family dwellings or larger, scattered open areas and fields are included.

*Protected* - Densely wooded terrain with the building not extending above the average height of surrounding obstructions (i.e., trees or buildings) and with the site design wind speed less than 130 mph.

*6.3 Commentary: Wind exposure is one of the most significant factors affecting the wind loads on low rise buildings, yet it is one of the most difficult parameters to define consistently. Most homes are sited in suburban or protected (i.e., shielded) exposures. For this reason, the suburban exposure (which is itself based on a fairly open terrain condition for the purpose of determining conservative design wind loads) is often used as a reasonable "default" condition for residential design. However, when homes are located in predominantly open terrain, such as an isolated home on the plains or oceanfront property, the open exposure condition must be used. In cases where the exposure is mixed, the designer may consider evaluating the building with different wind exposures relative*

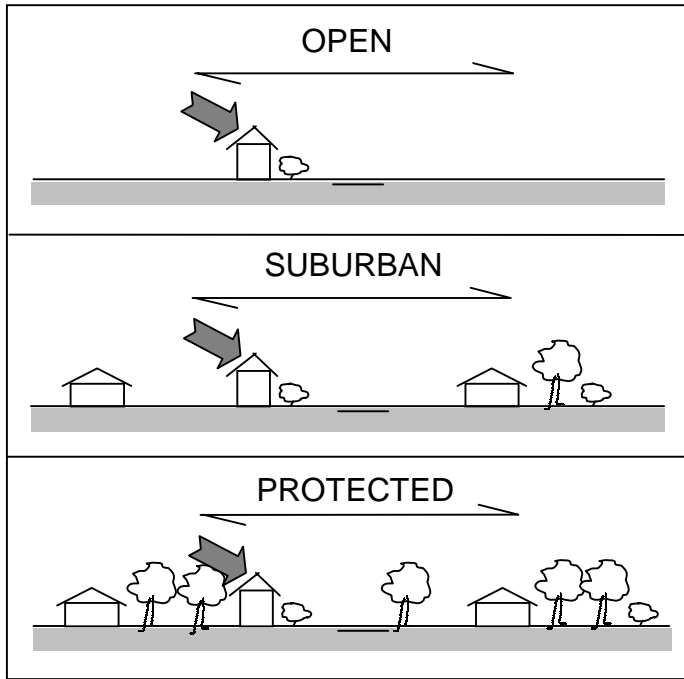

**FIGURE 6.3**  
**WIND EXPOSURE ILLUSTRATIONS**

**6.4 BASIC VELOCITY PRESSURE**

Using the site’s basic wind speed, the basic velocity pressure shall be determined in accordance with Table 6.4.

**TABLE 6.4**  
**BASIC WIND VELOCITY PRESSURES (psf)**  
**FOR SUBURBAN EXPOSURE<sup>1,2,3,4,5</sup>**

| BASIC WIND SPEED<br>(MPH, PEAK GUST) | ONE-, TWO- AND THREE-<br>STORY BUILDINGS |
|--------------------------------------|--|
| 85                                   | 12                                       |
| 90                                   | 13                                       |
| 100                                  | 16                                       |
| 110                                  | 19                                       |
| 120                                  | 23                                       |
| 130                                  | 27                                       |
| 140                                  | 31                                       |
| 150                                  | 36                                       |

Notes:

<sup>1</sup>For open wind exposure conditions, multiply the table values by 1.4.

<sup>2</sup>For protected exposure conditions, multiply the table values by 0.8.

<sup>3</sup>Topographic wind speed-up effects as experienced at or near the crest of protruding topographic features shall be considered in accordance with ASCE 7-98.

<sup>4</sup>For two-story buildings, multiply table values by 0.9; for one-story buildings, multiply table values by 0.8.

<sup>5</sup>Interpolation is permissible.

to wind direction or taking an “average” condition. Mixed protected and suburban exposures are typical in moderate to high density housing developments where adjacent homes shield one another in one wind direction and the general terrain condition (i.e., suburban) defines exposure for the other (orthogonal) wind direction. It should also be recognized that, with possible exceptions, exposure conditions will likely change over time as trees and developments mature and expand

6.4 Commentary: The basic wind velocity pressures of Table 6.4 are generated using the familiar relationship where velocity pressure (psf) equals  $0.00256 K_D K_z V^2$ , where  $K_z$  is the velocity pressure exposure coefficient associated with the vertical wind speed profile in suburban terrain at the mean roof height of the building.  $K_D$  is the wind directionality factor with a value of 0.85. For up to three-story buildings (mean roof height not exceeding approximately 35 ft), a  $K_z$  value of 0.75 is used. Since the table is based on the “default” assumption of suburban exposure, adjustments to other exposure conditions are provided in the table notes. In addition, homes located on or near the tops of large exposed hills and escarpments can experience significant topographic wind speed-up and increased loads. Houses sited in such conditions should be designed using an additional topographic factor adjustment in accordance with ASCE 7-98.

**6.5 LATERAL WIND LOADS ON WHOLE BUILDING**

To determine lateral wind pressures on the main wind force resisting system (MWFRS) of a building, multiply the appropriate lateral pressure coefficients from Table 6.5 by the basic wind velocity pressure from Table 6.4. These pressures shall be applied to the vertical projection of the roof and walls for two orthogonal directions of loading (parallel to ridge and perpendicular to ridge) as shown in Figure 6.5 for a gable roof building. For hip roof buildings, the roof vertical projected area shall apply to both directions of loading.

*6.5 Commentary: This simplified method of determining lateral wind loads is intended to facilitate the determination of lateral loads to be resisted by the building's shear walls and horizontal diaphragms (floors and roofs). Such methods have existed since the earliest consideration of wind loads on buildings. Lateral loads assigned to shear walls and horizontal diaphragms are typically determined based on the use of tributary area methods (i.e., assigning a lateral wind load based on a tributary portion of the vertical projected area). A more accurate method assigns lateral loads to shear walls based on relative stiffness of the walls (assuming a rigid diaphragm).*

**TABLE 6.5  
LATERAL PRESSURE COEFFICIENTS FOR APPLICATION  
TO VERTICAL PROJECTED AREA OF ROOF AND WALL**

| APPLICATION                    | LATERAL PRESSURE COEFFICIENTS <sup>1</sup> |
|--------------------------------|--|
| Roof Projected Area (by Slope) |  |
| Flat to 6:12                   | 0.5  |
| 7:12                           | 0.6  |
| 8:12 to 12:12                  | 0.7  |
| Wall Projected Area            | 1.1  |

Note:

<sup>1</sup>These values are composite pressure coefficients which include the effect of positive pressures on windward face of the building and negative (suction) pressures on leeward face of the building.

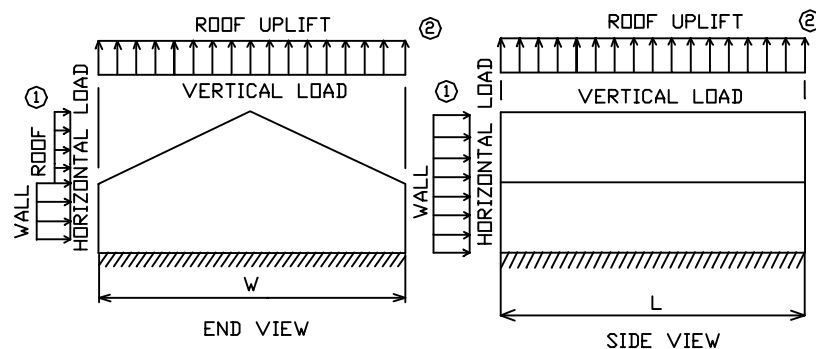

NOTES:

- ① APPLIED TO VERTICAL PROJECTED AREA
- ② APPLIED TO HORIZONTAL PROJECTED AREA

**FIGURE 6.5  
WIND LOADS FOR DESIGN OF MAIN  
WIND-FORCE RESISTING SYSTEM**

**6.6 WIND LOADS ON COMPONENTS, CLADDINGS, AND VARIOUS ASSEMBLIES**

To determine wind pressures on components and claddings, multiply the appropriate pressure coefficients from Table 6.6 by the basic wind velocity pressure from Table 6.4. With the exception of the roof uplift coefficient, all pressures calculated using these coefficients shall be applied perpendicular to the actual building surface area tributary to the component under consideration. The roof uplift pressure coefficient shall be used to determine a single wind pressure to be applied to the horizontal projected area of the roof assembly to determine roof tie-down connection forces and to evaluate the roof uplift contribution to building overturning forces as shown in Figure 6.5.

**TABLE 6.6  
PRESSURE COEFFICIENTS  
FOR BUILDING COMPONENTS, CLADDING, AND VARIOUS  
ASSEMBLIES**

| APPLICATION                                 | PRESSURE COEFFICIENTS <sup>1,2</sup>  |
|---|---|
| <b>ROOF</b>                                 |   |
| Trusses, Roof Beams, Ridge & Valley Rafters | -0.9, +0.4  |
| Rafters & Truss Panel Members               | -1.2, +0.7  |
| Roof Sheathing (panels, boards, or purlins) | -2.2, +1.0  |
| Skylights & Glazing                         | -1.2, +1.0  |
| Roof Uplift <sup>3</sup>                    | -1.0 (hip roof with slope less than 3:12)<br>-0.8 (hip roof with slope between 3:12 and 6:12)<br>-0.4 (hip roof with slope greater than 6:12)<br>-1.0 (gable roof of any slope) |
| Windward Overhang <sup>4</sup>              | +0.8  |
| <b>WALL</b>                                 |   |
| All framing members                         | -1.2, +1.1  |
| Wall Sheathing (panels, boards, or girts)   | -1.3, +1.2  |
| Windows, Doors, & Glazing                   | -1.3, +1.2  |
| Garage Doors                                | -1.1, +1.0  |

Notes:

<sup>1</sup>All coefficients include internal pressure in accordance with an enclosed building condition (i.e., no openings). Higher internal pressures shall be considered and table values adjusted in accordance with Section 6.7.

<sup>2</sup>Positive and negative signs represent pressures acting inward and outward, respectively, from the building surface. A negative pressure is a suction or vacuum. Both pressure conditions shall be considered.

<sup>3</sup>The roof uplift pressure coefficient is used to determine uplift pressures that are applied to the horizontal projected area of the roof for the purpose of determining uplift connection forces. Additional uplift force on roof connections due to windward roof overhangs shall also be included. The uplift force must be transferred through a continuous load path to the foundation or to a point where it is adequately resisted by the factored dead load of the building.

<sup>4</sup>The windward overhang pressure coefficient is applied to the underside of a windward roof overhang and acts upward on the bottom surface of the roof overhang. If the bottom surface of the roof overhang is also the roof sheathing, then the overhang pressure shall be additive to the roof sheathing pressure.

*6.6 Commentary: The pressure coefficients of Table 6.6 are based on a simplification of the ASCE 7-98 provisions. In addition, the coefficients are presented for the various systems and components typically found on homes. Coefficients are not provided for siding and roofing materials for two reasons: (1) air-permeable cladding systems (such as shingles and lap siding) are subject to reduced pressure differentials due to venting and (2) finish materials are often considered as a serviceability item with a lesser design criteria than would be used for safety. Therefore, it is not uncommon to multiply design wind loads by a factor of 0.75 when using the load for a serviceability purpose (i.e., checking building drift or attachment of finishes). Air-permeable cladding systems such as shingles or lap siding or brick may experience effective surface pressure coefficients of ±0.6 to ±0.9 in comparison to values of +1.1 to -2.2 experienced across an entire roof or wall system. In addition, items like roof shingles are usually “designed” for high wind use by specifying a greater number of nails per shingle (i.e., 6 nails per shingle in lieu of 4) and by requiring perimeter shingle tabs to be adhered with mastic. Thus, practical and comprehensive wind design is often a blend of simple calculation and good practice.*

## 6.7 INTERNAL PRESSURE

In hurricane-prone regions where design wind speeds are 120 mph or greater (see Figure A-2 of Appendix A) and where exterior glazed openings are not protected against potential wind-borne debris impacts as recommended in Section 6.9, buildings shall be designed in consideration of potentially increased internal pressure. In such consideration, the values in Table 6.6 shall be increased in positive or negative magnitude by  $\pm 0.35$ .

*6.7 Commentary: Internal pressure is a particular concern toward increased roof uplift forces. Internal pressure associated with the loss of windows and the existence of small openings in homes may not have wide spread affect on homes due to compartmentalization of the building and other factors. However, catastrophic losses of large openings (such as detachment of a garage door) often precipitate the types of roof blow-off damage and wall blow-out damage that are associated with internal pressurization. In high wind areas, particular attention should be focused on roof attachment and attachment of garage doors and similar large openings (i.e., slider doors or french doors).*

## 6.8 OVERTURNING FORCES

Lateral wind pressures and roof uplift pressure determined in accordance with Sections 6.5, 6.6, and 6.7 shall be used to determine overturning forces in accordance with the dead plus wind load combinations of Section 2.

*6.8 Commentary: Overturning is not normally a significant design issue for typical residential buildings. However, for tall homes with a relatively narrow plan dimension, overturning forces from lateral and roof uplift wind loads can create a stability problem which may require additional ballast or anchorage to the ground.*

## 6.9 WIND-BORNE DEBRIS PROTECTION

Wind borne debris protection, if required or desired, shall be designed in accordance with the local building code, the recommendations of this section, or local accepted practice.

*6.9 Commentary: The requirement of and specifications for wind-borne debris protection vary from locality to locality in hurricane-prone areas. Some require protection while others do not. There are various factors that may locally affect the potential for debris including local building practices, terrain exposure, and design wind speed. Current test methods and criteria for debris resistance of windows and doors do not necessarily represent these local factors. Therefore, this guide simply defers to local practice, but offers some recommended provisions for debris protection in particularly severe hurricane prone regions (i.e., 130 mph or*

**6.9.1 Temporary Shutters.** Adequate temporary shutters include minimum 7/16-inch-thick wood structural panels spanning no more than 8 feet and fastened to structural framing on the interior or exterior side of the glazed opening in accordance with Table 6.9.1.

**TABLE 6.9.1  
WINDBORNE DEBRIS PROTECTION FASTENING SCHEDULE  
FOR WOOD STRUCTURAL PANELS<sup>1,2</sup>**

| FASTENER TYPE                   | FASTENER SPACING (inches) |                       |                       |                       |
|---------------------------------|---------------------------|-----------------------|-----------------------|-----------------------|
|                                 | Panel Span<br>≤ 2 ft      | 2 ft < Span<br>≤ 4 ft | 4 ft < Span<br>≤ 6 ft | 6 ft < Span<br>≤ 8 ft |
| 2-1/2" x #6<br>Wood/Deck Screws | 16                        | 16                    | 12                    | 9                     |
| 2-1/2" x #8<br>Wood/Deck Screws | 16                        | 16                    | 16                    | 12                    |

Notes:

<sup>1</sup>This table is based on a maximum basic wind speed of 130 mph (gust). For a maximum basic wind speed of 140 mph, multiply fastener spacing values by 0.85. Fasteners should be installed at opposing ends of the wood structural panel.

<sup>2</sup>Screws shall penetrate wall framing members adjacent to the window or door opening. Where screws are applied to concrete or masonry construction, they shall have a minimum ultimate withdrawal capacity of 490 lbs.

**6.9.2 Permanent Shutters and Impact Resistant Glazing.** The impact resistance of shutters and glazing may be evaluated in accordance with criteria specified in Tables 6.9.2a and b or other approved criteria.

**TABLE 6.9.2a  
MISSILE TYPES<sup>1</sup>**

| MISSILE TYPE | DESCRIPTION | VELOCITY | ENERGY    |
|--------------|-------------|----------|-----------|
| B            | 4.5 lb 2x4  | 40 fps   | 100 ft-lb |
| C            | 9.0 lb 2x4  | 50 fps   | 350 ft-lb |

Notes:

<sup>1</sup>Missile types and impact velocities do not necessarily represent the types of debris or impact risks expected in typical residential settings.

<sup>2</sup>Impact tests should be conducted in accordance with ASTM E1886 - *Standard Test Method for Impact Resistance of Glazing* or other acceptable methods using the missile criteria of Table 6.9.2b.

**TABLE 6.9.2b  
WIND-BORNE DEBRIS MISSILE IMPACT  
CRITERIA FOR MISSILE TYPES DEFINED IN TABLE 6.9.2a**

|                      | DESIGN WIND SPEED (mph, peak gust) |     |     |
|----------------------|------------------------------------|-----|-----|
|                      | 130 <sup>1</sup>                   | 140 | 150 |
| <b>Missile Types</b> | B                                  | C   | C   |

Note:

<sup>1</sup>Missile type B may also be used in lower wind speed regions where local conditions are considered to be hazardous.

greater in Figure A-2 of Appendix A). The 130 mph condition reasonably delineates current localities where debris protection requirements may be enforced.

*6.9.1 Commentary: Plywood or similar temporary shutters have been used for some time by building owners in hurricane prone areas. It is important that the panels be installed with proper fastening to the building or window frame so that the panels do not detach from the building, expose the window opening, and become sources of debris impacting buildings downwind. Table 6.9.1 is provided as a simple prescriptive solution for temporary shutters.*

*6.9.2 Commentary: The criteria recommended in this section for determining debris resistance of shutters and impact resistant glazing products is believed to provide a conservative degree of protection relative to the predominant forms of debris found in typical residential settings during major hurricane events. Other more stringent standards have been developed and may be required by the local building code (e.g., South Florida Building Code). Use of impact resistant glazing and fixed shutters should also consider potential conflicting safety hazards such as hinderance of emergency (fire) egress. In addition, it may also be prudent to consider wall systems that offer a reasonable level of resistance to wind-borne debris impacts.*



## 7. SNOW LOAD (S)

### 7.1 GROUND SNOW LOAD

Ground snow loads shall be based on Figure A-3 of Appendix A or approved local climate data.

### 7.2 ROOF SNOW LOAD

The uniform roof snow load shall be determined in accordance with the following formula.

$$p = C_e C_s p_g$$

where values for  $C_e$  and  $C_s$  are as follows:

- $C_e = 0.8$  for windy areas with open exposure
- $= 1.0$  for typical suburban areas
- $= 1.2$  for sheltered or wooded areas
- $C_s = 1.0$  for slopes  $\leq 6:12$
- $= 0.9$  for 7:12 slope
- $= 0.8$  for 8:12 slope or greater

*7.2 Commentary: It is not uncommon in residential construction to simply equate the uniform roof snow load (placed on a horizontal projected area of the roof) to the ground snow load (i.e.,  $p = p_g$ ). In so doing, it is also common practice to neglect the consideration of off-balanced snow loading as required in Section 7.3.*

### 7.3 OFF-BALANCE SNOW LOAD

An off-balance snow load of  $0.8p$  on one side of the roof and  $1.2p$  on the opposite side of the roof shall be considered.

## 8. EARTHQUAKE LOAD (E)

### 8.1 GENERAL

Earthquake loads shall be determined in accordance with this section.

### 8.2 DESIGN GROUND MOTION

The site design ground motion shall be based on the short period spectral response acceleration,  $S_s$ , provided in Figure A-4 of Appendix A.

### 8.3 SEISMIC SHEAR LOAD

The total seismic shear (lateral) load for each level of the building shall be determined by the following formula:

$$E = 0.8 \left[ \frac{(S_s)(F_a)}{R} \right] W_g$$

Values for  $F_a$  and  $R_s$  shall be obtained from Tables 8.3a and 8.3b, respectively.

**TABLE 8.3a**  
**SITE AMPLIFICATION FACTOR ( $F_a$ ) FOR TYPICAL FIRM SOILS**

|       |             |      |      |      |             |
|-------|-------------|------|------|------|-------------|
| $S_s$ | $\leq 0.25$ | 0.50 | 0.75 | 1.00 | $\geq 1.25$ |
| $F_a$ | 1.6         | 1.4  | 1.2  | 1.1  | 1.0         |

Notes:

<sup>1</sup>Interpolation is permitted.

<sup>2</sup>For sites with soft soil conditions, see ASCE 7-98.

**TABLE 8.3b**  
**SEISMIC RESPONSE MODIFIERS - R**

| BUILDING SYSTEM                               | R   |
|---|-----|
| Light-frame walls (wood or cold-formed steel) |     |
| - with wood structural panel sheathing        | 6.0 |
| - stucco and wire lath                        | 4.0 |
| - gypsum wall board                           | 2.0 |
| Masonry walls                                 |     |
| - unreinforced                                | 1.5 |
| - reinforced                                  | 3.5 |
| Concrete walls                                |     |
| - unreinforced                                | 2   |
| - reinforced                                  | 4.5 |

*8.3 Commentary: The equation for the seismic lateral (shear) load, E, is a simple application of Newtonian mechanics (i.e., force equals mass times acceleration) and it follows a traditional seismic design approach while making use of newer seismic ground motion parameters and mapping data. The acceleration component is associated with the parameter,  $S_s$ , as modified by  $F_a$  and R. The building mass subject to the seismic acceleration is defined by  $W_g$ . The seismic weight,  $W_g$ , includes the tributary dead load of supported portions (stories) of the building and its permanently fixed components and equipment. Live Loads are not included. It is customary to include 20 percent of the roof snow load in  $W_g$  where ground snow loads are 30 psf or greater. The 0.8 coefficient adjusts  $S_s$  to a 475-yr return period design basis and accounts for uncertainties in simplified seismic design by increasing the load by 20 percent. Thus, it is derived from two factors as follows:  $(2/3)(1.2) = 0.8$ .*

*The seismic design provisions in this section are in part based on extraction of relevant design information from the NEHRP 1997 seismic design provisions published by the Federal Emergency Management Agency, Washington, DC. While*

*not considered necessary for typical residential construction, more complicated methods of design and more detailed data on  $F_a$  and  $R$  may be found in the NEHRP seismic provisions or ASCE 7-98.*

#### **8.4 DISTRIBUTION OF STORY SHEAR LOAD**

The story shear load shall be distributed to and resisted by shear walls in a manner that does not induce unacceptable torsional response or overloading due to differences in stiffness of various structural systems or building configuration. Acceptable methods to distribute seismic story shear load to supporting shear walls or other vertical shear resisting elements include the use of tributary building weight (dead load) or stiffness-based procedures. Seismic story shear loads shall be considered in separate directions acting parallel to each major axis of the building. Stability shall be provided by adequate direct shear, torsional, and overturning resistance.

#### **8.5 VERTICAL SEISMIC FORCES**

Vertical seismic forces shall be evaluated in accordance with accepted engineering practice only when the live load is less than one-half the dead load supported by the vertical load resisting system of the building.

*8.5 Commentary: Light buildings have rarely (if ever) exhibited any significant problem associated with vertical acceleration during seismic events (which is usually taken as 2/3rds of the horizontal seismic acceleration). However, for heavier buildings the gravity load analysis (which includes live loads) may not provide adequate resistance to vertical seismic forces which are calculated considering only the dead load (as amplified by the increased vertical acceleration above that of gravity). Therefore, a vertical load analysis is required when the live load (as used in gravity load analysis) is only one-half or less of the building dead load. For typical light frame homes, this requirement does not apply.*



**APPENDIX A  
DESIGN DATA**

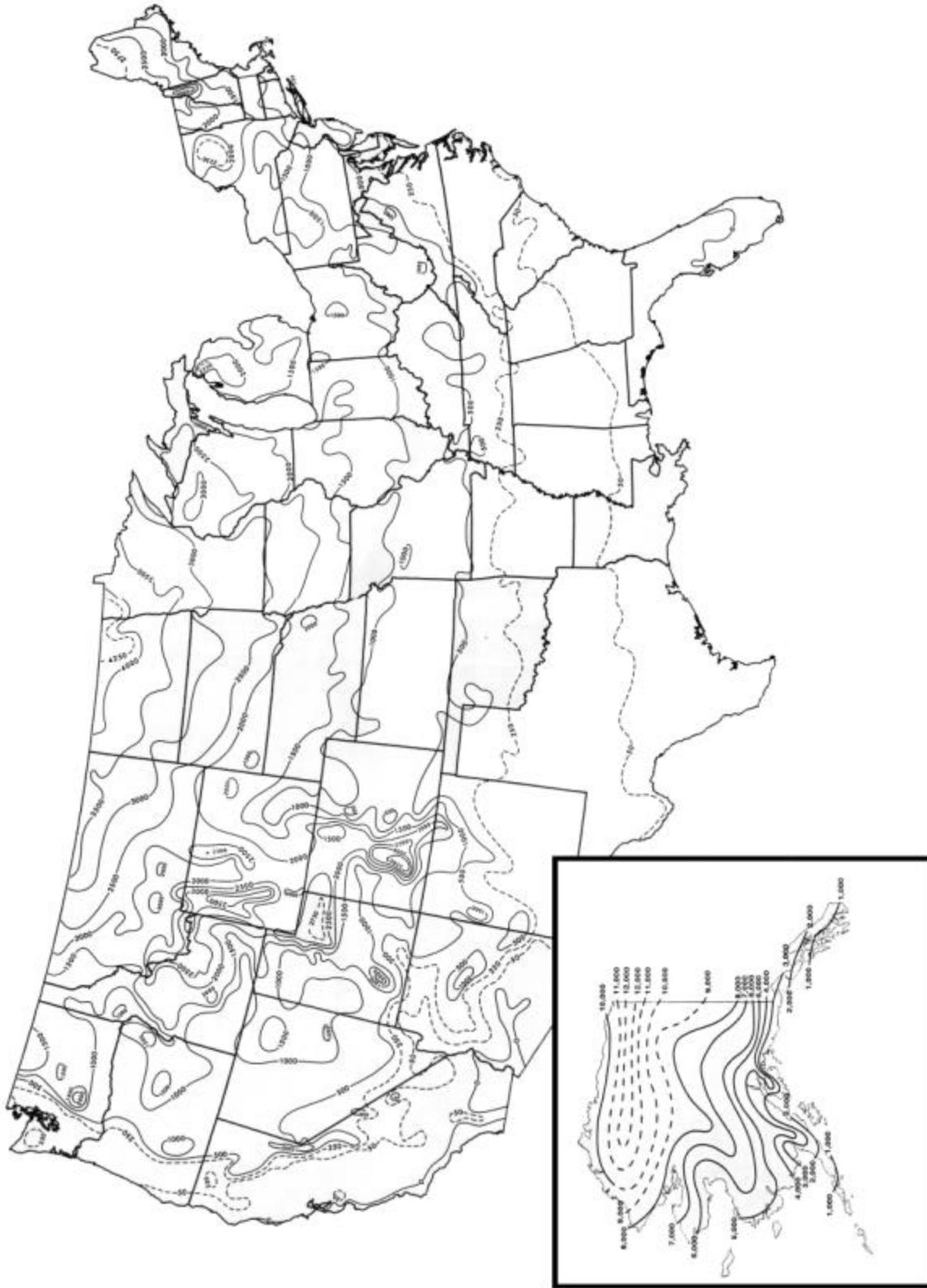
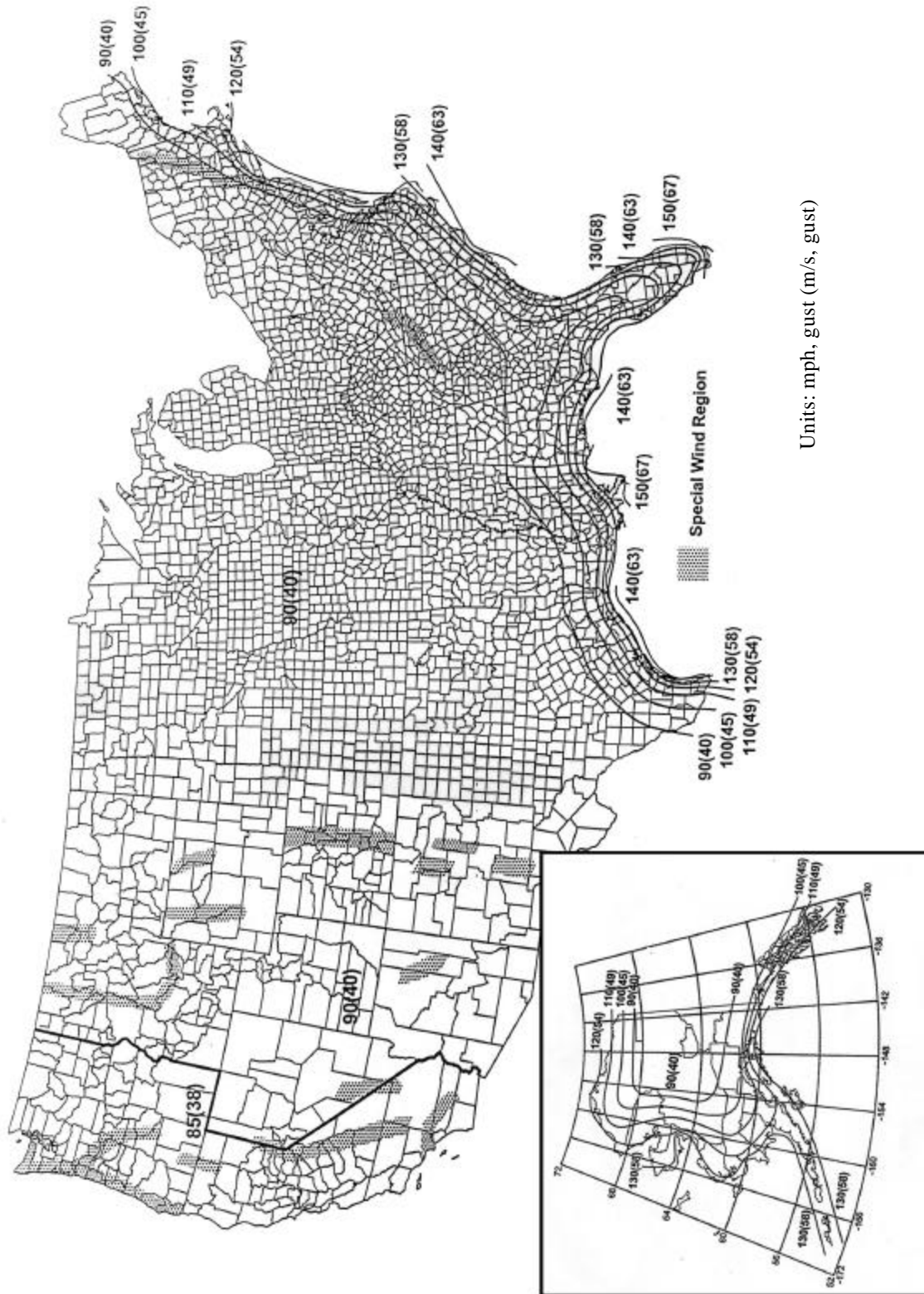
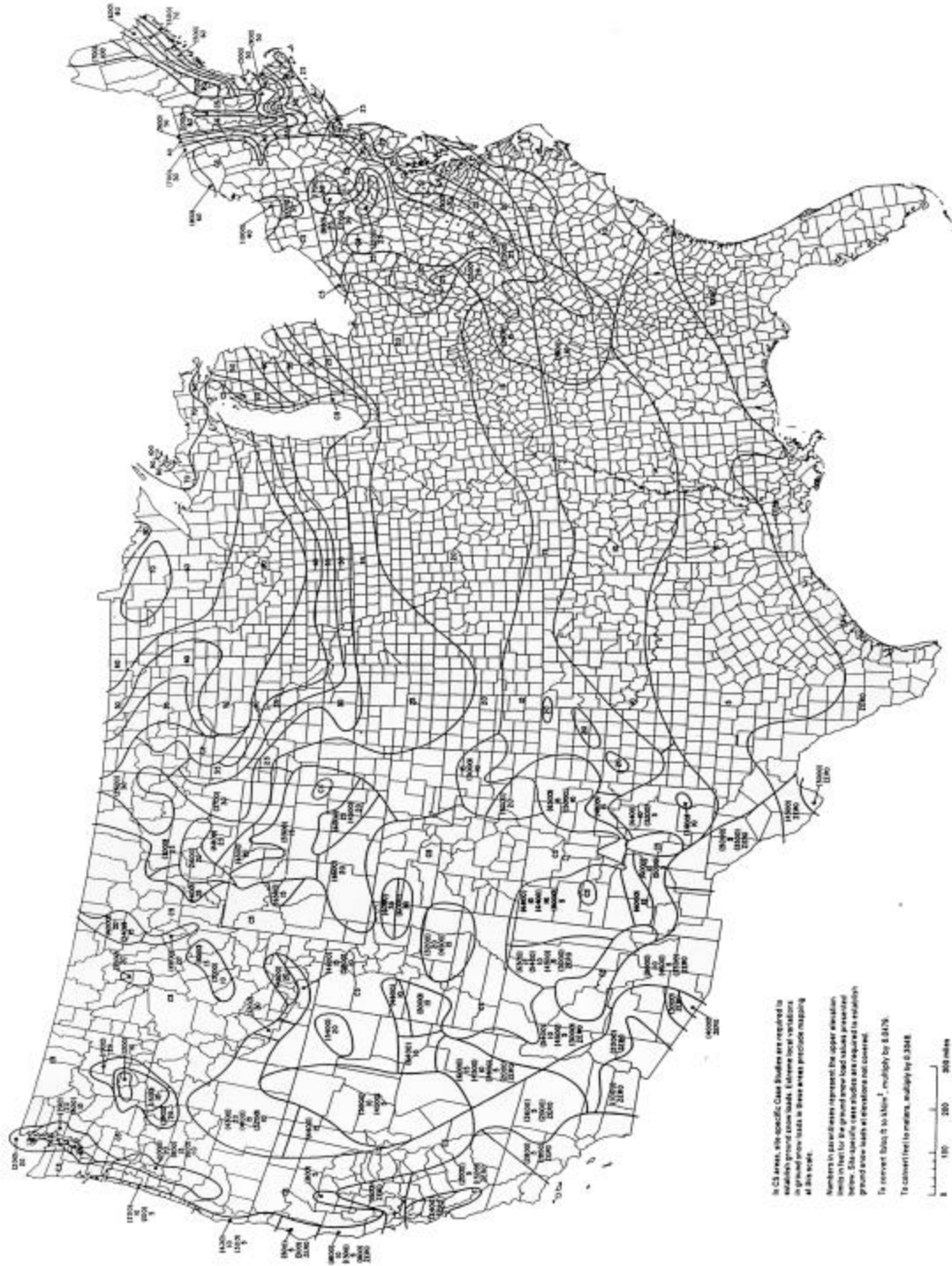

FIGURE A-1  
AIR-FREEZING INDEX (° F-DAYS) FOR 100-YEAR RETURN PERIOD  
BASED ON ANNUAL EXTREME VALUES



**FIGURE A-2**  
**BASIC WIND SPEED MAP FOR UNITED STATES**

Source: American Society of Civil Engineers, Reston, VA  
 Ref: ASCE 7-98



**FIGURE A-3**  
**GROUND SNOW LOADS FOR THE UNITED STATES (psf)**

Source: American Society of Civil Engineers, Reston, VA  
 Ref: ASCE 7-98



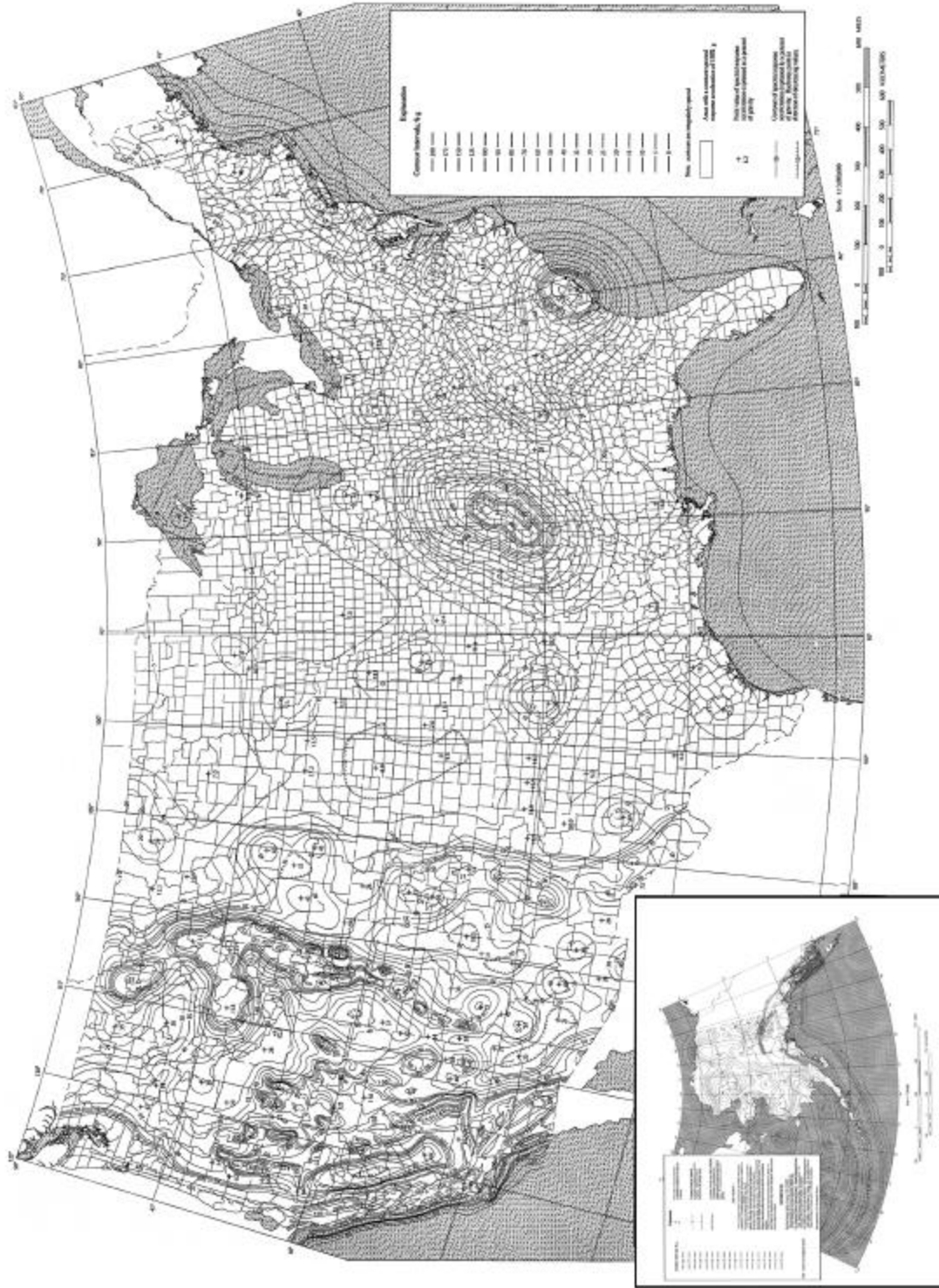

Units: %g, short period (0.2 sec)  
spectral response acceleration

**FIGURE A-4**  
**EARTHQUAKE GROUND MOTION MAP OF THE UNITED STATES**

Source: American Society of Civil Engineers, Reston, VA  
Ref: ASCE 7-98

## **APPENDIX B SUPPLEMENTAL DESIGN REFERENCES**

This list of design references is not intended to be exhaustive and earlier editions of these references may also be used.

### **GENERAL DESIGN & BUILDING CODE REFERENCES**

*Minimum Design Loads for Buildings and Other Structures* (ASCE 7-98), American Society of Civil Engineers (ASCE), Reston, VA (2000).

*International Residential Code*, International Code Council, Inc., Falls Church, VA (2000).

*International One- and Two-Family Dwelling Code*, International Code Council, Inc., Falls Church, VA (1998).

*One- and Two-Family Dwelling Code*, Council of American Building Officials, Falls Church, VA (1995)

*Uniform Building Code*, International Conference of Building Officials, Whittier, CA (1997).

*Standard Building Code*, Southern Building Code Congress International, Inc., Birmingham, AL (1999).

*National Building Code*, Building Officials and Code Administrators International, Inc., Country Club Hills, IL (1999).

*Residential Structural Design Guide – 2000 Edition*, U.S. Department of Housing and Urban Development, Washington, DC (2000).

### **WOOD DESIGN**

*National Design Specification for Wood Construction* (ANSI/AF&PA-NDS), American Forest & Paper Assoc. (AF&PA), American Wood Council, Washington, DC (1997).

*Load and Resistance Factor Design (LRFD) Manual for Engineered Wood Construction*, American Forest & Paper Association (AF&PA), American Wood Council (1996).

*National Design Standard for Metal Plate Connected Wood Truss Construction* (ANSI/TPI 1-95), Truss Plate Institute, Madison, WI 1995.

### **HIGH WIND CONDITIONS**

*Wood Frame Construction Manual for One and Two Family Dwellings – 1995 SBC High Wind Edition*, American Forest & Paper Association (AF&PA), Washington, DC (1996).

*Standard for Hurricane Resistant Residential Construction* (SSTD 10), Southern Building Code Congress International, Inc. (SBCCI), Birmingham, AL (1999).

**CONCRETE**

*Building Code Requirements for Structural Concrete (ACI 318-95)*, American Concrete Institute (ACI), Detroit, MI (1995).

*Design and Construction of Post-Tensioned Slabs-on-Ground (First Edition, Sixth Printing)*, Post-Tensioning Institute (PTI), Phoenix, AZ (1993).

*Residential Concrete Construction (ACI-332)*, American Concrete Institute (ACI), Detroit, MI (1982).

**MASONRY**

*Building Code Requirements for Masonry Structures (ACI-530/ASCE-5/TMS-402)*, American Concrete Institute (ACI), Detroit, MI (1999).

**STEEL**

*Specification for Design of Cold-Formed Steel Structural Members*, American Iron & Steel Institute (AISI), Washington, DC (1996).

*Manual of Steel Construction - Allowable Stress Design*, Ninth Edition, American Institute of Steel Construction (AISC), Chicago, IL (1989).

*Manual of Steel Construction - Load and Resistance Factor Design*, Volume 1, Second Edition, American Institute of Steel Construction (AISC), Chicago, IL (1995).

**FROST PROTECTION**

*Design Guide for Frost-Protected Shallow Foundations, Second Edition*, NAHB Research Center, Inc., Upper Marlboro, MD (1996).

*Design and Construction of Frost-Protected Shallow Foundations (ASCE 32-01)*, American Society of Civil Engineers, Reston, VA (2001).

**SOIL**

*Bearing Capacity of Soils*, Technical Engineering and Design Guides as adapted from the U.S. Army Corps of Engineers, No. 7, American Society of Civil Engineers, Reston, VA (1993).

## APPENDIX C METRIC CONVERSION FACTORS

~~The following list provides the conversion relationship between U.S. customary units and the International System (SI) units. A complete guide to the SI system and its use can be found in ASTM E 380, Metric Practice.~~

| To convert from | to | multiply by |
|-----------------|----|-------------|
|-----------------|----|-------------|

### Length

|            |                |        |
|------------|----------------|--------|
| inch (in.) | meter (μ)      | 25,400 |
| inch (in.) | centimeter     | 2.54   |
| inch (in.) | meter (m)      | 0.0254 |
| foot (ft)  | meter (m)      | 0.3048 |
| yard (yd)  | meter (m)      | 0.9144 |
| mile (mi)  | kilometer (km) | 1.6    |

### Area

|                      |                           |             |
|----------------------|---------------------------|-------------|
| square foot (sq ft)  | square meter (sq m)       | 0.09290304E |
| square inch (sq in)  | square centimeter (sq cm) | 6.452 E     |
| square inch (sq in.) | square meter (sq m)       | 0.00064516E |
| square yard (sq yd)  | square meter (sq m)       | 0.8391274   |
| square mile (sq mi)  | square kilometer (sq km)  | 2.6         |

### Volume

|                           |                          |            |
|---------------------------|--------------------------|------------|
| cubic inch (cu in.)       | cubic centimeter (cu cm) | 16.387064  |
| cubic inch (cu in.)       | cubic meter (cu m)       | 0.00001639 |
| cubic foot (cu ft)        | cubic meter (cu m)       | 0.02831685 |
| cubic yard (cu yd)        | cubic meter (cu m)       | 0.7645549  |
| gallon (gal) Can. liquid  | liter                    | 4.546      |
| gallon (gal) Can. liquid  | cubic meter (cu m)       | 0.004546   |
| gallon (gal) U.S. liquid* | liter                    | 3.7854118  |
| gallon (gal) U.S. liquid  | cubic meter (cu m)       | 0.00378541 |
| fluid ounce (fl oz)       | milliliters (ml)         | 29.57353   |
| fluid ounce (fl oz)       | cubic meter (cu m)       | 0.00002957 |

### Force

|               |               |           |
|---------------|---------------|-----------|
| kip (1000 lb) | kilogram (kg) | 453.6     |
| kip (1000 lb) | Newton (N)    | 4,448.222 |
| pound (lb)    | kilogram (kg) | 0.4535924 |
| pound (lb)    | Newton (N)    | 4.448222  |

### Stress or pressure

|                     |                                       |            |
|---------------------|---------------------------------------|------------|
| kip/sq inch (ksi)   | megapascal (Mpa)                      | 6.894757   |
| kip/sq inch (ksi)   | kilogram/square centimeter (kg/sq cm) | 70.31      |
| pound/sq inch (psi) | kilogram/square centimeter (kg/sq cm) | 0.07031    |
| pound/sq inch (psi) | pascal (Pa) **                        | 6,894.757  |
| pound/sq inch (psi) | megapascal (Mpa)                      | 0.00689476 |
| pound/sq foot (psf) | kilogram/square meter (kg/sq m)       | 4.8824     |
| pound/sq foot (psf) | pascal (Pa)                           | 47.88      |

| To convert from | to | multiply by |
|-----------------|----|-------------|
|-----------------|----|-------------|

### Mass (weight)

|                        |               |           |
|------------------------|---------------|-----------|
| pound (lb) avoirdupois | kilogram (kg) | 0.4535924 |
| ton, 2000 lb           | kilogram (kg) | 907.1848  |
| grain                  | kilogram (kg) | 0.0000648 |

### Mass (weight) per length

|                             |                           |          |
|-----------------------------|---------------------------|----------|
| kip per linear foot (klf)   | kilogram per meter (kg/m) | 0.001488 |
| pound per linear foot (plf) | kilogram per meter (kg/m) | 1.488    |

### Moment

|                      |                    |       |
|----------------------|--------------------|-------|
| 1 foot-pound (ft-lb) | Newton-meter (N-m) | 1.356 |
|----------------------|--------------------|-------|

### Mass per volume (density)

|                                 |                                    |          |
|---------------------------------|------------------------------------|----------|
| pound per cubic foot (pcf)      | kilogram per cubic meter (kg/cu m) | 16.01846 |
| pound per cubic yard (lb/cu yd) | kilogram per cubic meter (kg/cu m) | 0.5933   |

### Velocity

|                     |                               |         |
|---------------------|-------------------------------|---------|
| mile per hour (mph) | kilometer per hour (km/hr)    | 1.60934 |
| mile per hour (mph) | kilometer per second (km/sec) | 0.44704 |

### Temperature

|                        |                     |                            |
|------------------------|---------------------|----------------------------|
| degree Fahrenheit (°F) | degree Celsius (°C) | $t_C = (t_F - 32)/1.8$     |
| degree Fahrenheit (°F) | degree Kelvin (°K)  | $t_K = (t_F + 459.7)/1.8$  |
| degree Kelvin (°F)     | degree Celsius (°C) | $t_C = (t_K - 273.15)/1.8$ |

\* One U.S. gallon equals 0.8327 Canadian gallon

\*\* A pascal equals 1000 Newton per square meter.

The prefixes and symbols below are commonly used to form names and symbols of the decimal multiples and submultiples of the SI units.

| Multiplication Factor           | Prefix | Symbol |
|---------------------------------|--------|--------|
| 1,000,000,000 = 10 <sup>9</sup> | giga   | G      |
| 1,000,000 = 10 <sup>6</sup>     | mega   | M      |
| 1,000 = 10 <sup>3</sup>         | kilo   | k      |
| 0.01 = 10 <sup>-2</sup>         | centi  | c      |
| 0.001 = 10 <sup>-3</sup>        | milli  | m      |
| 0.000001 = 10 <sup>-6</sup>     | micro  | μ      |
| 0.000000001 = 10 <sup>-9</sup>  | nano   | n      |





U.S. Department of Housing and Urban Development  
HUD User  
P.O. Box 6091  
Rockville, MD 20849

Official Business  
Penalty for Private Use \$300

Return Service Request

FIRST-CLASS MAIL  
POSTAGE & FEES PAID  
HUD  
Permit No. G-795